

# MASTERS OF FINE ART MATERIALS

---

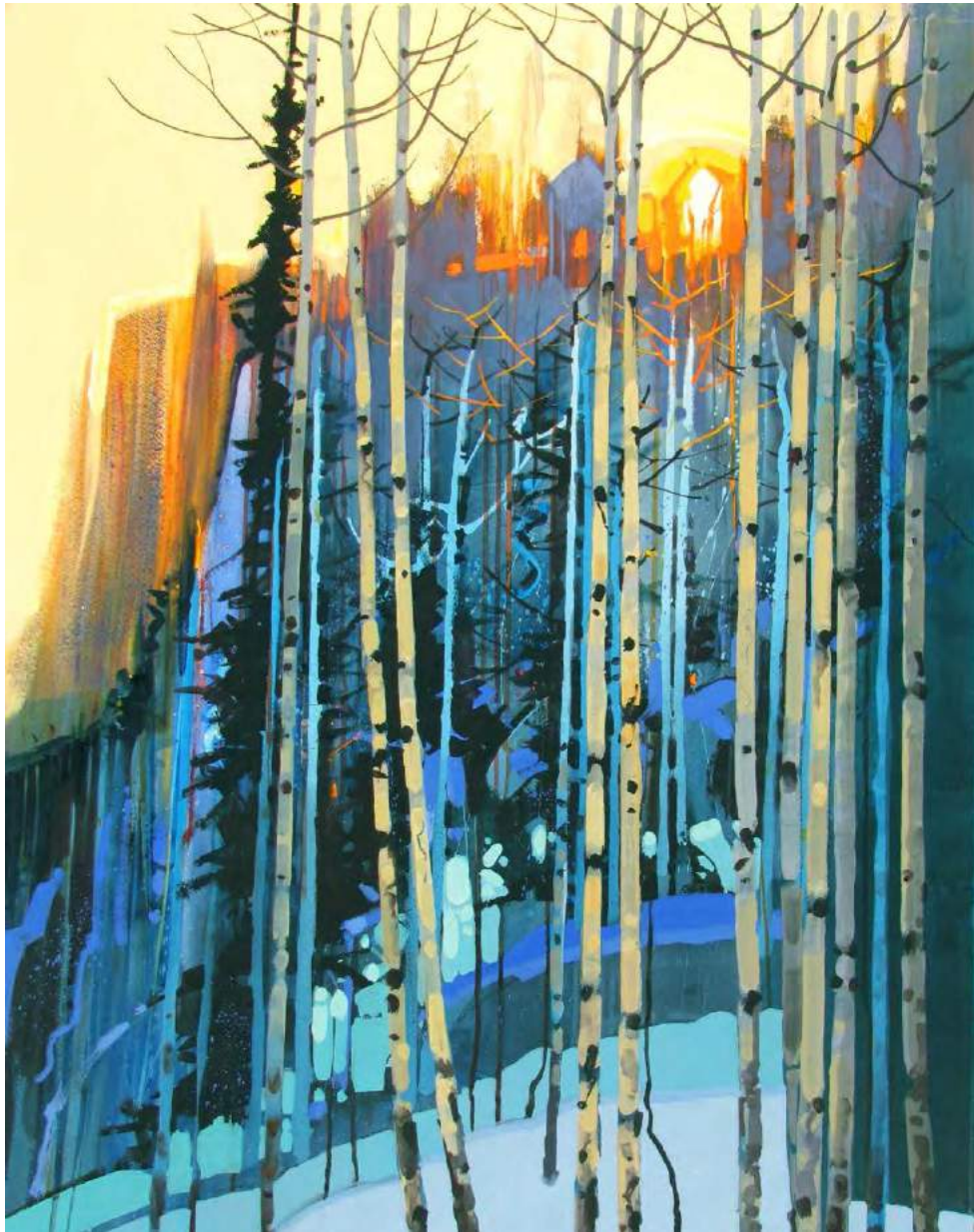

Painting by Stephen Quiller  
[www.stephenquiller.com](http://www.stephenquiller.com)



**Jack Richeson**  
& Co., Inc.

Jack Richeson and Co. is based on a belief in the  
**IMPORTANCE OF ART...**  
its relevance... its necessity in life. We search the world to provide  
quality materials for artists. What we can't find, we make ourselves.

We collect art. We teach. We listen. We are involved.

To be involved with art is a joy.  
To be involved with artists is an honor.

## Table of Contents

Introduction	3-7
Brushes	8-49
Brush Sets/Assortments	50-52
Painting Knives	53-57
Paint	58-92
Pastels/Sketch Sticks	93-109
BEST Easels	110-129
BEST Taborets/Benches	130-139
Richeson Lyptus® Wood Easels	140-143
Richeson Easels/Stools	144-153
Palettes/Trays/Paint Cups	154-165
Brush Washers	166
Pottery/Sculpture Tools	167-174
Paper/Surfaces/Canvas	175-187
Stretcher Bars	188-195
Wooden Storage Boxes	196-197
Canvas Accessories/Portfolios	198-199
Printing Presses	200-201
Linoleum/Lino Tools	202-203
Manikins/Sundries	204-209
Books/Videos	210
Color Guides	211
Index	212-214

## Jack Richeson & Co., Inc. Manufacturers & Importers of Fine Artist's Materials

Jack Richeson & Co., Inc.  
557 Marcella St., P.O. Box 160  
Kimberly, WI 54136-0160  
Phone Orders: 1-800-233-2404  
920-738-0744  
E-Mail Orders: orders@richesonart.com  
Fax Orders: 1-800-233-2545  
920-738-9156  
Web Site: www.richesonart.com  
Office Hours: weekdays, 8-5, C.S.T.



### Safety Labeling

Like you, we are concerned about the safe use of our products in the studio and in the classroom. We feel it is important to label our products under the regulations of ACMI. The Art and Creative Materials Institute, Inc. (ACMI) is a non-profit trade association of art and craft materials manufacturers. Since 1940, ACMI has conducted a certification program in which members' product formulas are analyzed by a renowned toxicologist and certified by ACMI as non-toxic or properly labeled for health hazards.

Note: Consumers with special health concerns or specific allergies are encouraged to consult with their physicians.



Jack Richeson & Co. products bearing the AP Label are considered safe to use without special handling precautions or health concerns for the general population. They are considered safe for use by children.



Jack Richeson & Co., Inc. products bearing the CL Label have been found to contain ingredients that may cause acute or chronic health problems or may require special handling, disposal, or safety apparatus. Consumers must follow safety guidelines on our package to ensure their health and safety. **CL labeled products are not for use by children.**

NEVER FORGET  
**WHO YOU ARE**  
OR WHERE  
**YOU CAME**  
**FROM**

## HOW IT ALL BEGAN

Excerpt from “Confessions of a Brush Peddler”

by Jack Richeson

*Memories are sometimes like snapshots from a camera. As I sip the first of my ever-so-good Manhattan, I'm thinking of my Auntie “O”. My parents called her Mrs. Kozil, but as I grew up, I called her Auntie “O” because I couldn't say Kozil.*

*It was October of 1932 and Dad was out of work. Mom, Dad and my three sisters were living in the basement of an abandoned tenement at 3400 North Springfield Street in Chicago. I wasn't there yet but would appear in the next fifteen minutes. Mom was in hard labor and she was trying to get the girls ready to deliver another sister. The girls – Rosalie was eleven, Betty - sixteen and Mary Louise was big sister at seventeen – were scared to death to think of delivering a baby. Rosalie had run down the street to get Mrs. Kozil to come and help.*

*Mrs. Kozil was a large woman. She swept off the large oak kitchen table and sent the girls out to beg, borrow or steal candles. There was no electricity in the building. Auntie “O” washed off the table and then covered it with several old sheets. The girls came back with five or six candles and another neighbor, Mrs Zangerle, who had a flashlight. The two ladies helped my mother up on the table and tried to calm her through a rough delivery.*

*Fifteen minutes later young Jack Richeson entered the world screaming like hell. My mother*



*out-screamed everyone, but not out of pain alone. She couldn't believe she had a boy. My father, who had been out in what had been an old laundry room drinking with Mr. Kozil, came in singing “Danny Boy”. He told the world that my name would be Danny Runyon Richeson. My mother now holding me, screamed back that my name would be Jack and that after finally having a son she would not have him named after another drunken Irishman. She couldn't change his nationality but she could make sure that he would never drink, he would go to college and he would be someone.*

*Oh, sorry, Mother, you missed on all counts. I could never sing like my father, but I was blessed with all his other bad habits – wine, women and listening to other people's songs were to be the roadmap for a great part of my life.*

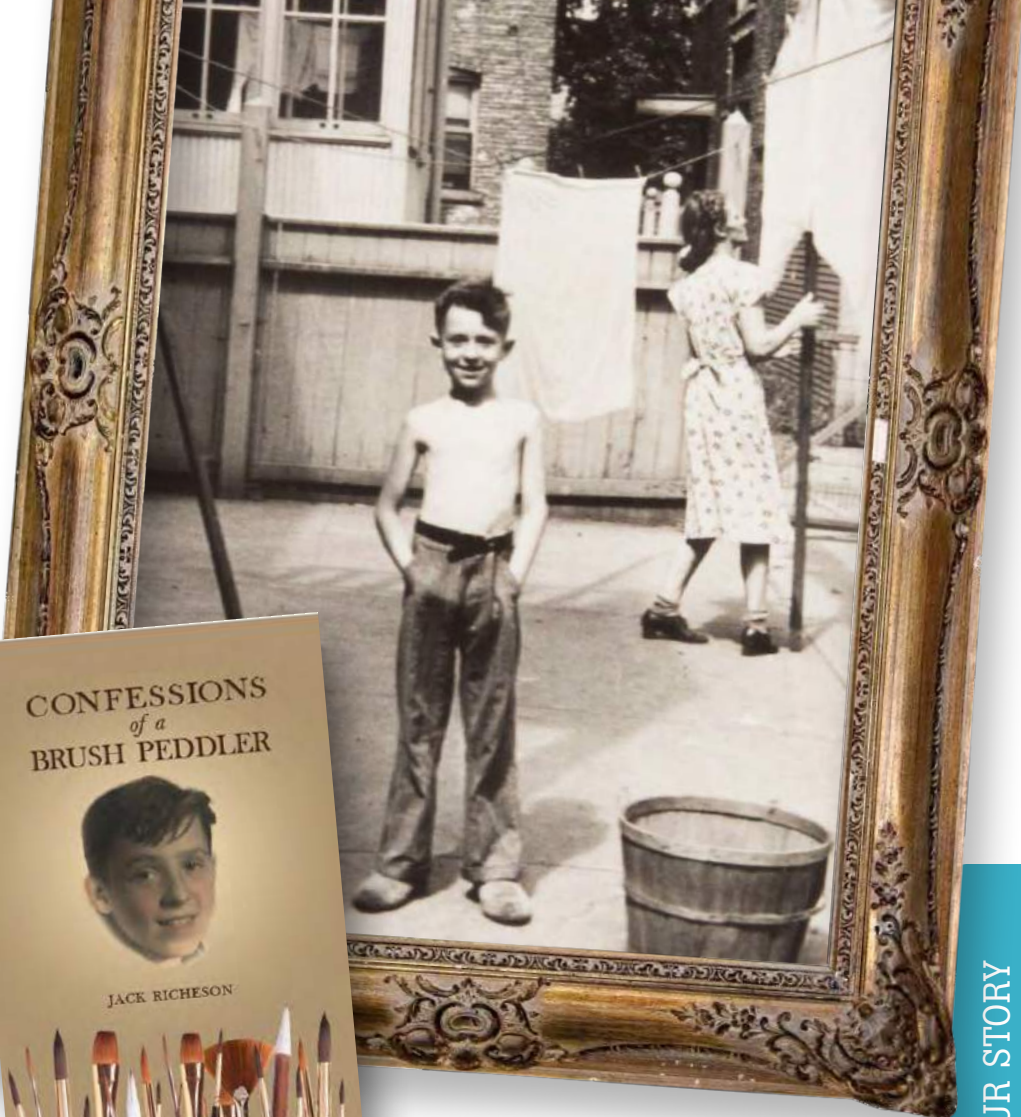

## Jack's Master Plan

An Irish dreamer from his birth in 1932, Jack wrote his first business plan at the young age of 17. The goals were clearly identified: he wanted to be a painter, and he wanted to get rich. How is that for simplicity? He had been requested to remove himself from high school his senior year. From the stories told over the years, it was hardly because of exemplary behavior or that he excelled past the education the school could offer.

In spite of this, he somehow got accepted into the Art Institute of Chicago. Again, he was requested to remove himself. The term “Attention Deficit” had not yet been recognized. The phrase of the day was “There goes a Bad Kid.” It was obvious that his plan was going nowhere. The smart ones reassess and redesign. “The Survivors” rely on luck and evolution.



Above: Linda and Jack Richeson, CEO

Jack's luck turned when he was rescued by Sheldon Goldman—the owner of the prominent Chicago art supply store *Sheldon's*—after Jack attempted to steal the hubcaps from Sheldon's gorgeous 1938 LaSalle. Sheldon took Jack under his wing. He learned the art supply business from the ground up. He started as an errand boy, then moved from truck driver, to clerk, to salesman, to manager, to entrepreneur. Every step along the way was with the assistance of his painter friends.

Jack enjoyed and benefited greatly from the coaching and teaching of amazing well known painters such as Ben Stahl, Sessions, and Haddon Sunbloom. Today he enjoys the friendship of modern day legends such as Ramon Kelley, Burt Silverman, Daniel Greene, Ray Kinstler, Kate Palmer, Robert

Tanenbaum, Steve Quiller, Urania Christy Tarbet, Buffalo Kaplinski, Skip Whitcomb, Brenda Mattson, Chris Van Winkle and Tom Fong. The list goes on FOREVER—there are just too many to list them all. They all coached, prodded and unknowingly helped write Jack's plan. They gathered the family together and seduced them into the wonderful world of art. This journey would take the Richesons from storing stock in the attic of an 1890s Victorian home near Downtown Appleton, Wisconsin to the amazing building that now houses Jack Richeson & Co.

In the early 1950s, Jack took a brief time out from Sheldon's while he served in the Army. It was here that he met young Ruth Hinde in Rushden, England while stationed at Chelveston Air

Base. The love between the two is the "stuff" romance novels are made from.

After Jack was released from the Army, they married in Chicago. Jack went back to work at Sheldon's, and they began their family. From Sheldon's, Jack went on to work with Bob Sachs and Favor Ruhl; eventually opening a couple of craft stores in the Chicago Suburbs. In the mid-1970s, Jack was National Sales Manager for Grumbacher. During the late 70's Jack was offered a position as President of Morilla and the family moved to Massachusetts.

At 50 years old, Jack found himself in the middle of major corporate changes at Morilla. The end result was a move from Massachusetts to Appleton, Wisconsin with Ruth and the two kids who were still living at home. The move resulted in the birth of Jack Richeson & Co., Inc.



Above: Colleen Richeson-Maxey and Jackie Richeson

In the mid 90's Ruth began to experience significant health issues. In spite of this, she continued to be a strong influence on the company and an encourager to her family. Sadly in 2000, the family lost Ruth to lung cancer. A void was created in their lives that could never be filled. Several years after losing Ruth, Jack met a bright, bubbly Scottish Blue Badge Guide on a business trip to Britain, who had herself lost her mate years earlier. Jack and Linda were married in 2004 at Gleneagles, Scotland.



Above: Kelly M Richeson, Michael Richeson, and Darren Richeson

## The Richesons Today

Today the working family members include Jack (CEO) and wife Linda, and most of Jack's adult children (Yes, there are some not in the business). Darren Richeson – President, Shawn Richeson – Executive Vice President of Manufacturing, Kelly M. Richeson – Vice President of Finance, Colleen Richeson Maxey – Vice President of Sales & Marketing, Michael Richeson – Vice President of National Accounts. Jack's oldest granddaughter and name-sake Jackie Richeson is the company Compliance Specialist. Shawn's wife Kelly L. Richeson oversees paint manufacturing as well as production.

In years past Darren's wife Michelle ran the graphics art department. Today Michelle is a well known professional painter. Many of her pieces are on display at the Richeson School of Art and Gallery.

Colleen's husband Greg handled purchasing for a couple of years after retiring from the USAF. The Company has provided summer and holiday work over the years for teenage and college grandchildren as well as for the children of many employees.

Jack's love and fascination with art, artists and materials has spread through the family. All of the families are collectors. Over 400 pieces from Jack's private collection can be seen on the walls of the Richeson School of Art and Gallery, along with amazing pieces from some of today's great painters.



Above: Shawn and Kelly Richeson

## To our Artist Friends

Too many to list, every family member is deeply aware that artists are the reason we exist. For you, we are truly grateful!



## RICHESON SCHOOL OF ART & GALLERY

### Jack's Dream

The very first time a young Jack Richeson met an artist, the seeds of a dream were planted. The first buds resulted in a strong desire to own one of these precious miracles he watched artists create. As a young man and soon one with a growing family, it was a faraway dream. It would be years before Jack owned his first painting, and each year the yearning grew stronger.

In the early 1980s with a small start-up company called Jack Richeson & Co., Inc, Jack became fast friends with well-known watercolorist Zoltan Szabo and a young Colorado painter, Stephen Quiller, who was developing quite a reputation of his own. These friendships offered Jack the opportunity to be able to own his first real paintings. With each painting his hunger for more paintings grew as did his passion to support the artists who painted them.

As the company grew, Jack began the tradition of giving each of his children a painting at Christmas. Jack's passion for owning more amazing pieces spread throughout the family. Today the family's personal collection numbers over 900 pieces. That passion and those collections created a new challenge for Jack. Everyone ran out of walls!

### The Dream Grew

What if we were to place a Gallery and School of Art right here in the Kimberly building? Jack's dream grew to include not only expanded space for the family collection, but a place where school children could come to see the works of modern day painters. It would be a place where "children" from the very young to those 100+ could see that they too could learn to paint regardless of their age.



in a large octagon shaped area in the center of the Gallery, creating an environment that encircles students with amazing pieces of art as they take a class or attend open studio. The classroom is large enough to accommodate two classes, each with twenty students. The lighting has been specially selected to provide the best possible light.

The Gallery surrounds the School. The walls are filled with modern day masterpieces, and it is a place that offers tranquility and visual pleasure to anyone who visits. Most recently added is the Zoltan Szabo collection of nearly 50 watercolor pieces. Each of these very special paintings captures the essence of most of the States in the U.S. as well as the Provinces of Canada. Local artists as well as nationally known painters have their work on



display and available for purchase. In the Gallery, several walls are reserved to display a rotation of local shows and the top selected entrants of the International Richeson75 Competitions.

### The Dream Continues to Grow

In 2014, Jack Richeson & Co., Inc. was pleased to add Shannon Piette as Director of the Richeson School of Art and Gallery. Shannon is a graduate of UW Stevens Point with a degree in Studio Arts and Business. Shannon has brought energy, enthusiasm as well as a personal commitment to make the Gallery and School of Art a destination place for artists everywhere.

As Jack made plans with the family, it was determined that the school would be a vehicle to reach out into the community. It would be a place where artists of any level could meet for Open Studio during the week, learn from each other and share experiences. The dream grew to include a place to sponsor national workshops for people to learn from modern masters in a variety of mediums.

### Dreams Became Reality

Today the building houses an amazing 25,000 square foot Gallery and School of Art. The School is nestled



# THE IMPORTANCE OF QUALITY MATERIALS

## What Do the Masters Use?

Over the years Jack has been extremely fortunate to have met and worked with some of the finest painters in the world. Ben Stahl, Haddon Sundblom, Sessions, and the great Zoltan Szabo are just a few of these wonderful masters.

Today Ray Kinstler, Ramon Kelley, Burt Silverman, Lawrie Williamson, Stephen Quiller, Brenda Mattson, Bill Canright, Urania Tarbet and Kate Palmer are just a few of the amazing painters that Jack and the family have the pleasure of knowing and working with.

## All of these great artists agree on the importance of top quality materials.

Top quality materials are even more important to a young painter who is often discouraged when poor quality paint and brushes short stop the very skills he seeks to master. Many a promising young painter gives up discouraged believing it is their lack of talent. In truth, poor materials are limiting the young painter's ability to learn.

Several years ago, Jack was fortunate enough to watch the great Bill Draper do a demonstration at the Portrait Society Show in Washington D.C. Afterwards, Jack waited until the crowd had dispersed and went up to the stage. Jack was shocked to see that Bill was using cheap bristle brushes! When asked about them, Bill grinned and said that on

a quick demo he would use economy brushes because he didn't want to take the time for clean up. He then added that at his studio, when working on a commission, he used the finest tools available. Bill Draper, a true master, knew the value of quality tools.

**Materials are tools.** Tools are critically important in the whole painting process. How you select these tools may have a bearing on the quality of your finished work as well as a definite impact on how well you enjoy your work.

But materials cost so much, you say. Let's look at the cost. Recently we acquired an absolutely beautiful 22 x 30 watercolor painting for our gallery. The cost was \$4,000.00.

## Analysis using Professional, Quality Materials

Overhead (per month)	\$109.99
Insurance (per month)	\$ 85.00
Brushes (amortized)	\$13.60
Paper	\$18.40
Paint	\$40.00
Misc.	\$25.00
<b>Total cost</b>	<b>\$291.99</b>

## Analysis using the Cheapest, Lowest Quality Materials.

Overhead (per month)	\$109.99
Insurance (per month)	\$85.00
Brushes (amortized)	\$4.00
Paper	\$2.50
Paint	\$10.00
Misc.	\$25.00
<b>Total cost</b>	<b>\$236.49</b>

The difference in using the best and using junk is just over \$55.00! The painting sold for \$4,000.00 so we know that the materials were not a factor. Isn't the integrity of the artist selling work worth \$50?

**Dealers** – educate painters on the value of quality materials and how poor materials can negatively affect their reputation.

**Painters** – please take heed! Your talent and your reputation are integrally tied together. Don't damage either with poor quality materials.

## Good quality artist materials are not inexpensive, but you get what you pay for in performance and reliability.

Take some time and test a Kolinsky Sable Brush. Feel the difference when using a pure interlocked Bristle Brush. See how little color is needed when mixing a high quality oil color with Titanium White to get a good strong tint. Cheap oils take lots of color mixed with white to get close to the same tint as the higher quality oil. These are just a couple of examples.

**On each page of this catalog** you will find important product information that we hope will guide you to make better decisions on materials to stock if you are a dealer or materials to use if you are an artist. Spend the time to read the copy, but most importantly—trust your judgment.



# GREY MATTERS BRUSHES

## Why does "GREY MATTER" with brushes?

We love talking to artists! During these talks, we heard about the struggle artists face with glaring studio lights or the sun outdoors reflecting off the ferrules. Further distractions came from brush handles and even colored brush heads.

### GREY MATTERS BRUSHES:

- Fade from notice
- No distracting colors or reflective metals
- Neutral grey for minimal color distortion
- Non-reflective hair, ferrule and handle

Try **GREY MATTERS** brushes for Oils, Acrylics, and Watercolors!

BRUSHES

∞

www.richesonart.com

1.800.233.2404



9841 Round Series Size Chart

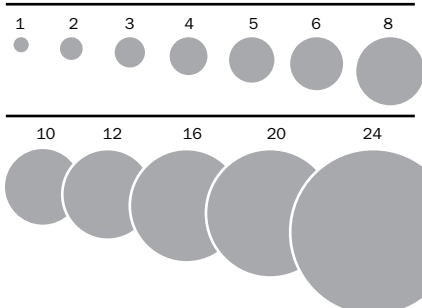

9842 Flat, 9843 Bright and 9844 Filbert Series Size Chart

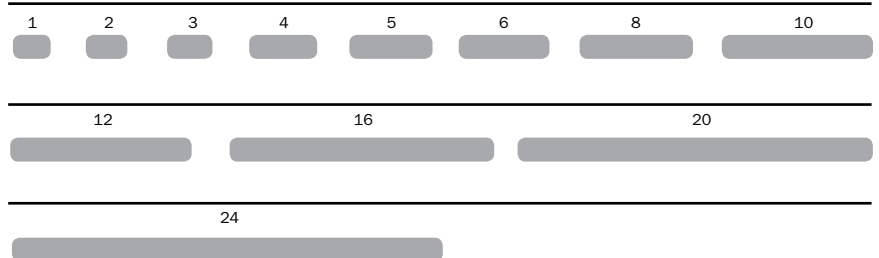



# GREY MATTERS BRISTLE OIL BRUSHES



These interlocked long-handled bristle brushes are painstakingly crafted by hand. Interlocked brushes ensure that the bristles maintain their shape and last for long time.

## Rounds Series 9841 Long Handle

NUMBER	SIZE
984101	1
984102	2
984103	3
984104	4
984105	5
984106	6
984108	8
984110	10
984112	12
984116	16
984120	20
984124	24

## Brights Series 9843 Long Handle

NUMBER	SIZE
984301	1
984302	2
984303	3
984304	4
984305	5
984306	6
984308	8
984310	10
984312	12
984316	16
984320	20
984324	24

## Flats Series 9842 Long Handle

NUMBER	SIZE
984201	1
984202	2
984203	3
984204	4
984205	5
984206	6
984208	8
984210	10
984212	12
984216	16
984220	20
984224	24

## Filberts Series 9844 Long Handle

NUMBER	SIZE
984401	1
984402	2
984403	3
984404	4
984405	5
984406	6
984408	8
984410	10
984412	12
984416	16
984420	20
984424	24

## Egberts Series 9845 Long Handle

NUMBER	SIZE
984502	2
984504	4
984506	6
984508	8
984510	10
984512	12

## Fans Series 9846 Long Handle

NUMBER	SIZE
984602	2
984604	4
984606	6
984608	8

See Grey Matters Signing Brushes on page 11.

See page 13 for the full line of Grey Matters assortments!

9845 Egbert Series Size Chart



9846 Fan Series Size Chart



BRUSHES

9

www.richesonart.com

1.800.233.2404

# GREY MATTERS SYNTHETIC OIL BRUSHES



GREY MATTERS™ offers an Oil Synthetic Brush as well as an Acrylic Synthetic Brush. Why? Because for painters, one size (or shall we say firmness) does NOT fit all.

Featuring a slightly softer feel, perfect for glazing!

### Rounds Series 9811 Long Handle

NUMBER	SIZE
981101	1
981102	2
981103	3
981104	4
981106	6
981108	8
981110	10
981112	12

### Brights Series 9814 Long Handle

NUMBER	SIZE
981401	1
981402	2
981403	3
981404	4
981406	6
981408	8
981410	10
981412	12

### Filberts Series 9813 Long Handle

NUMBER	SIZE
981301	1
981302	2
981303	3
981304	4
981306	6
981308	8
981310	10
981312	12

### Flats Series 9812 Long Handle

NUMBER	SIZE
981201	1
981202	2
981203	3
981204	4
981206	6
981208	8
981210	10
981212	12

9811 Round Series Size Chart

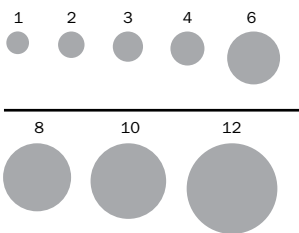

9812 Flat, 9814 Bright and 9813 Filbert Series Sizes

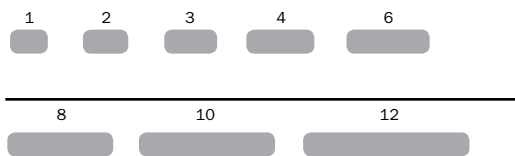

"I know when I need a brush to cut in an edge, mass in an area, lay in thick or thin paint and even small details, my "Grey Matters" brushes can do the job. Whatever my brush stroke requires, they perform when it counts. I love their durability and spring."

– Connie Lynn Reilly  
www.conniereilly.com

# GREY MATTERS ACRYLIC BRUSHES



Introducing **Grey Matters Acrylic Brushes!**  
Designed for the firmness required to move acrylic paint with ease.

## Rounds Series 9821 Long Handle

NUMBER	SIZE
982101	1
982102	2
982103	3
982104	4
982106	6
982108	8
982110	10
982112	12

## Filberts Series 9823 Long Handle

NUMBER	SIZE
982301	1
982302	2
982303	3
982304	4
982306	6
982308	8
982310	10
982312	12

## Signing Brushes

A brush designed specifically for signing your paintings. The brush has the desired flexibility and control needed for the signing of your work.

A specially designed handle shape and length give the brush just the right feel in the artist's hand. Can be used with oils, watercolors, acrylics – virtually any medium!

## Flats Series 9822 Long Handle

NUMBER	SIZE
982201	1
982202	2
982203	3
982204	4
982206	6
982208	8
982210	10
982212	12

## Brights Series 9824 Long Handle

NUMBER	SIZE
982401	1
982402	2
982403	3
982404	4
982406	6
982408	8
982410	10
982412	12

## Signing Series 9815 Mid-Length Handle

NUMBER	SIZE
981555	3/0
981544	2/0
981500	0
981501	1
981502	2
981503	3

9821 Round Series Size Chart

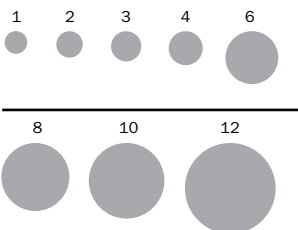

9822 Flat, 9824 Bright and 9823 Filbert Size Chart



9815 Signing Series Size Chart



# GREY MATTERS WATERCOLOR BRUSHES



Only the highest quality synthetic filaments are used in our **Grey Matters Watercolor Brushes**. Suitable for all types of water media.

Multiple filament types to achieve the highest:

- Loading ability
- Snap
- Point or chisel
- Even release of color

**See Signing Brushes shown on Page 11.**

## Rounds Series 9831 Short Handle

NUMBER	SIZE
983166	4/0
983155	3/0
983144	2/0
983100	0
983101	1
983102	2
983103	3
983104	4
983105	5
983106	6
983108	8
983110	10
983112	12
983114	14
983116	16
983120	20
983124	24

9831 Round Series Size Chart

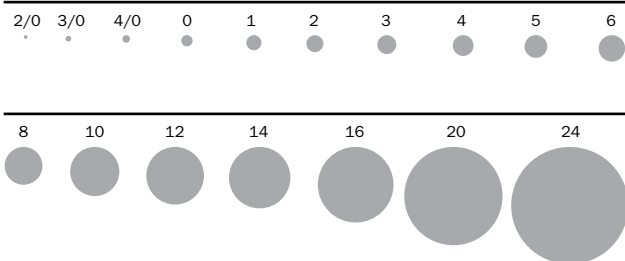

## Flats Series 9832 Short Handle

NUMBER	SIZE
983200	1/8"
983205	3/16"
983225	1/4"
983250	1/2"
983275	3/4"
983210	1"
983251	1-1/2"
983220	2"
983230	3"
983240	4"

## Liners Series 9833 Short Handle

NUMBER	SIZE
983344	2/0
983300	0
983301	1
983302	2
983304	4

9833 Liners Series Size Chart



# GREY MATTERS BRUSH SETS & ASSORTMENTS

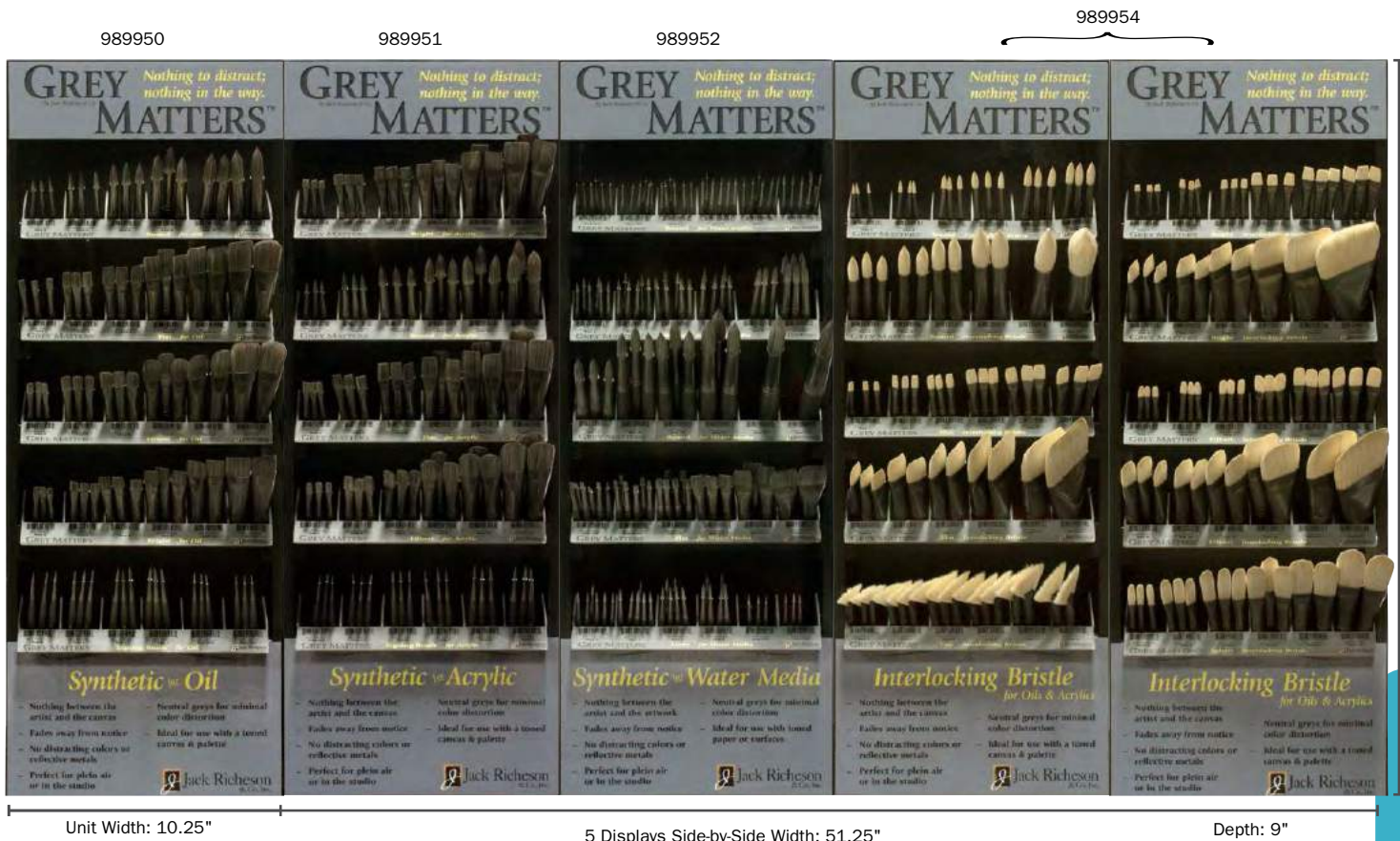

Height: 27.5"

BRUSHES

## Grey Matters Assortment Displays

The Grey Matters displays are an attractive, consumer-friendly way to display all that the Grey Matters line has to offer. Available in a variety of assortments, you can mix and match your unit selection to meet your specific needs. Call for assortment contents.

NUMBER	DESCRIPTION
989950	Synthetic Oil Assortment (1 display)
989951	Synthetic Acrylic Assortment (1 display)
989952	Synthetic Watercolor Assortment (1 display)
989953	Interlocking Bristle Assortment (Partial Range - 1 display) <i>Not Shown</i>
989954	Interlocking Bristle Assortment (Full Range - 2 displays)



13

## GREY MATTERS BRUSH SETS

Grey Matters Brushes are available in a variety of carded sets that are perfect for use in the classroom or workshop.

### Grey Matters Set of 6 Synthetic Oil Brushes

Contains 981102, 981106, 981206, 981306, 981406, 981500

NUMBER 989901

### Grey Matters Set of 6 Acrylic Brushes

Contains 982102, 982106, 982206, 982306, 982406, 981500

NUMBER 989902

### Grey Matters Set of 4 Signing Brushes

Contains 981555, 981544, 981500, 981501

NUMBER 989903

### Grey Matters Set of 6 Watercolor Brushes

Contains 983100, 983103, 983106, 983110, 983250, 983301

NUMBER 989904

### Grey Matters Set of 6 Bristle Oil Brushes

Contains 984106, 984206, 984306, 984406, 984504, 984602

NUMBER 989905

www.richesonart.com

1.800.233.2404

# EXTREME KOLINSKY BRUSHES

BRUSHES

14

www.richesonart.com

1.800.233.2404

## ARTIST'S NOTE:

There are no laws in the U.S. to protect the consumers from fraudulent use of the trade names Kolinsky or Sable, so it is buyer beware. Learn to tell by feel. Check the snap, check the point. Make sure that a brush performs like the name on the handle.

Grid color chart courtesy of Stephen Quiller.  
[www.quillergallery.com](http://www.quillergallery.com)

# EXTREME KOLINSKY BRUSHES



## What is Kolinsky?

The first known use of the name Kolinsky was around 1851. The term refers to several varieties of Asian Weasels. Most typically referenced is the Marten weasel. The yellowish brown tail from the weasel is used to make high grade artist brushes.

The finest Kolinsky hair comes from the Kolin Peninsula and then from a very high ratio of male hair to female hair. The female lives in an underground burrow and is rarely outside. The male is the hunter and forager. He hunts to bring food back to the family. Because he is outdoors most of the time, his coat is rich and thick and long. Their natural diet is one reason why farming these weasels has never been very successful.

## Why Extreme Kolinsky?

Over the years, we have observed a shift in the quality of Fine Artist Brushes. As the market drives prices down, eventually a lowering of quality can occur. Richeson has sought out the world's finest brush maker to produce a Kolinsky watercolor brush that will exceed the dreams and demands of the most discriminating painter. Each brush is carefully created by hand using only the highest possible percentage of male hair.

- Quality to challenge any Kolinsky watercolor brush
- Loads and releases color evenly
- Point and snap that painters dream and yearn for
- Made by skilled German artisans

## Rounds Series 7777

NUMBER	SIZE
777755	3/0
777744	2/0
777700	0
777701	1
777702	2
777703	3
777704	4
777705	5
777706	6
777708	8
777710	10
777712	12
777714	14

## Flats Series 7778

NUMBER	SIZE
777825	1/4"
777850	1/2"
777875	3/4"
777810	1"
777851	1 1/2"



7777 Round Series Size Chart

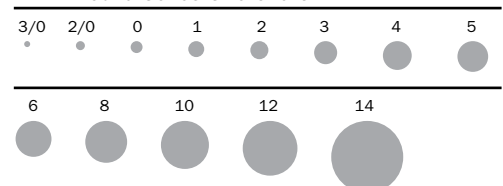

Assortment shown on page 52.  
Number 995077

# FINEST SABLE HAIR WATERCOLOR BRUSHES



These boxes are great for storing brushes!

## Good

### A. Sable Series 6228 Short Handle Rounds

Our excellent quality 6228/6229 red-sable brushes offer a beautiful snap and point in the rounds and an incredible chisel on the flat. We strive to offer a great sable for the budget-conscious artist.

NUMBER	SIZE
622855	3/0
622844	2/0
622800	0
622801	1
622802	2
622803	3
622804	4
622805	5
622806	6
622808	8
622810	10
622812	12
622814	14

### B. Sable Series 6229 Short Handle Flats

NUMBER	SIZE
622950	1/2"
622975	3/4"
622910	1"
622951	1-1/2"

## Best

### C. Pure Sable Series 7223 Short Handle Rounds

Perfect for the folds desiring an even higher quality than our 6228/6229 series! We use Sable hair that comes from a Northern Province of Russia. Our 7223 brush is the finest pure Sable watercolor brush on the market. Available in traditional English sizes.

NUMBER	SIZE
722355	3/0
722344	2/0
722300	0
722301	1
722302	2
722303	3
722304	4
722305	5
722306	6
722308	8
722310	10
722312	12
722314	14

\*No assortment available.

6228 Round Series Size Chart

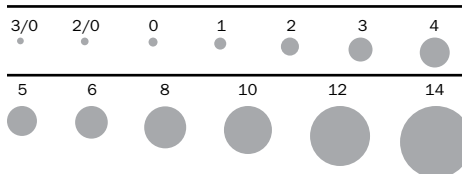

### Sable Brush Set of 5

Includes sizes 2/0, 1, 3 and 8 of series 6228 and size 3/4" of series 6229. Polybagged.

NUMBER 622898

### Sable Brush Set of 3

Includes round sizes 8, 10 and 14. Packaged in a wooden box.

NUMBER 622899

### Finest Sable Watercolor Set of 2

Great for gift giving or for just storing brushes, this set comes in a slide top wooden box. Contains size 14 of series 6228 and size 1" of series 6229. (See page 10 for brush information.)

NUMBER 994052

7223 Round Series Size Chart

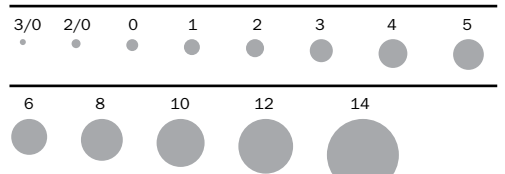

Assortment shown on page 50. Number 995039



# NATURAL HAIR LINERS & SPOTTERS

## What is Sable?

We often hear confusion between the terms Kolinsky and Sable. It is common to refer to the hair used for the highest quality natural hair brushes as Kolinsky Sable. It is a common misconception that the use of the term Sable must then also mean the highest quality.

In actual function, Sable Brushes would be considered a grade below Kolinsky Sable. Sable should be an excellent quality brush, but may have a higher mix of female hair bringing the cost of the brush down. Both can have a place in the artists tool box.

The unique shape of each strand of hair is what makes hair from these animals so great for brush making. It's a by-product of the fur industry as only the hair from the tail of the weasel is used in brush making.

## Caring for Brushes

Paint brushes are an investment and you want to get the most for your money as you possibly can. If you care for it properly, a good brush will serve you for many years. Here are a few ways you can protect your investment and avoid having to replace your brushes before they've reached their life expectancy.

- Clean your brushes as soon as you are finished painting. Paint of any type, even water-based paint, should never be allowed to dry in a brush.
- Do not use oil brushes for any other medium. Once used with oils, these brushes should be kept exclusively for use with your oils.
- Brushes should dry flat or be hung in a head down position to protect the shape. Allow your brushes to dry thoroughly before storing them in closed containers.
- Keep your brush handles and ferrules dry. Even the finest brush handles will loosen and crack when left soaking. Fill your water or solvent container so that it nearly covers the brush head.
- Natural hair brushes get burnt out just like human hair especially when solvents are used. Lard oil has been a traditional conditioner for oil brushes as long as anyone remembers. It's inexpensive and found in any good hardware store. **Jack's Linseed Studio Soap is also an excellent conditioner! See page 81.**



BRUSHES

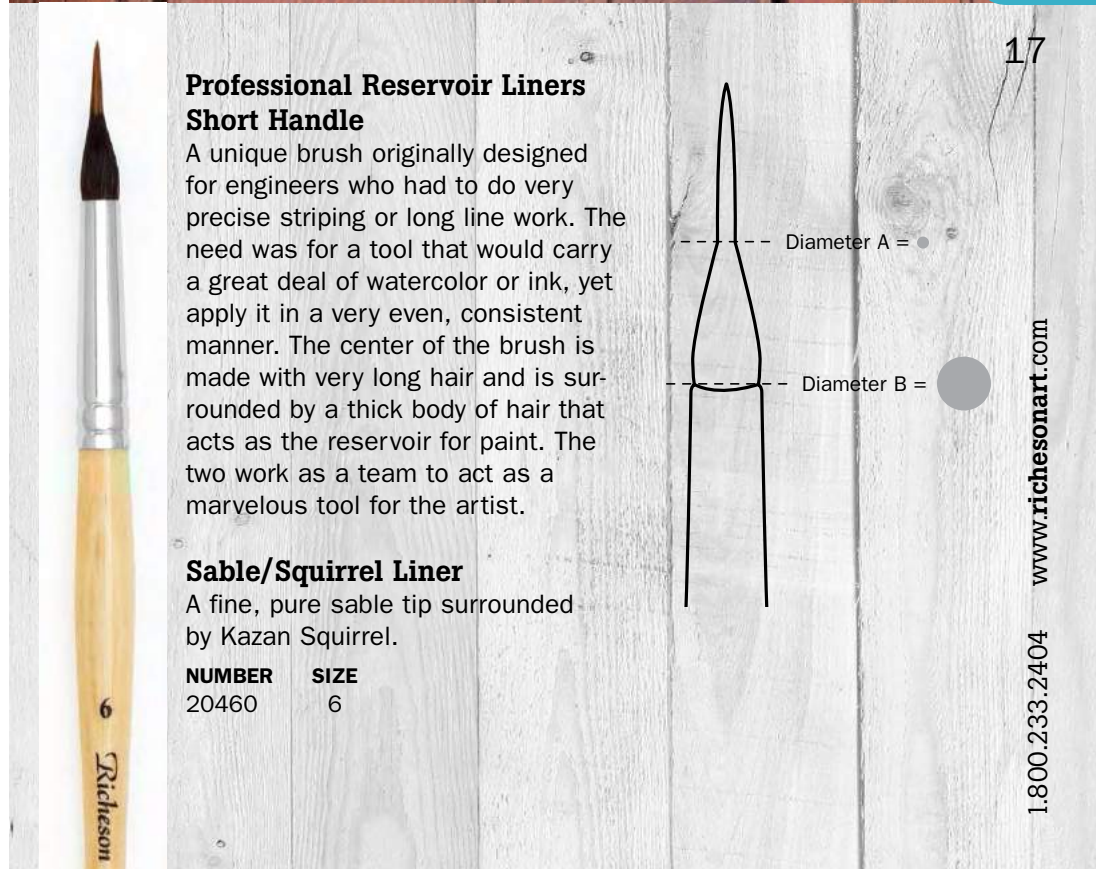

## Professional Reservoir Liners Short Handle

A unique brush originally designed for engineers who had to do very precise striping or long line work. The need was for a tool that would carry a great deal of watercolor or ink, yet apply it in a very even, consistent manner. The center of the brush is made with very long hair and is surrounded by a thick body of hair that acts as the reservoir for paint. The two work as a team to act as a marvelous tool for the artist.

## Sable/Squirrel Liner

A fine, pure sable tip surrounded by Kazan Squirrel.

NUMBER	SIZE
20460	6

# PURE KAZAN SQUIRREL WATERCOLOR BRUSHES



Painting by Kate Palmer  
www.katepalmer.com

These brushes are unique! For many years, fine quality Squirrel hair was unavailable because of the restrictions caused by the “Cold War”. Today, we have a fantastic source for natural hair and, even better than that, a marvelous team of old world brush makers.

Our brush factory negotiates directly with the fur trappers in Siberia for first choice of the very best prized Kazan Squirrel hair. Each brush is expertly hand-crafted. The hair is carefully selected, processed and prepared for the final stages of brush craft. The brush heads are hand-tied, glued, fitted to seamless ferrules, and then glued and crimped onto natural wooden handles. Artists will be amazed at the performance of these fantastic tools.

## Kazan Squirrel Short Handle

Perfect for large watercolor washes, these pure Kazan Squirrel brushes can hold a lot of liquid. They are also great for varnishing – it goes on smooth, with no bubbles!

NUMBER	SIZE
20510	1"
20520	1-3/4"

## *This brush is great for varnishing an oil painting!*

Read what renowned artist, Kate Palmer, has to say about using this brush for varnishing:

“The very properties that make the Kazan squirrel flat wash brush great for watercolor also make it a superb varnishing brush for oil painters. The unique Kazan squirrel hair holds a lot of liquid, is soft and supple like no other hair, yet is easy to control.

In varnishing, this means it can ride the irregular surface of an oil painting, leaving a consistently thin coat of varnish without pooling or grabbing, and it can cover a reasonable area without reloading. Always desirable, these qualities are critical to my way of working.

I often start several paintings at one time in the studio, and go to the one that speaks most clearly to me while the others wait for completion. When I do a very large painting, say four by five feet, I may work it in stages, letting it dry in between. In both instances, the paint is not bone dry and this soft squirrel brush meets my need to put on a thin layer of retouch varnish without lifting either the thin transparent washes or the thick juicy passages that characterize my work.”

*NOTE: When using any natural hair brush in this manner, be sure to wash the brush immediately after use and do not let it soak in turpentine for long periods of time, as this will damage the delicate hair.*



Artist Kate Palmer lives and works in New Mexico.

# PURE KAZAN SQUIRREL WATERCOLOR BRUSHES

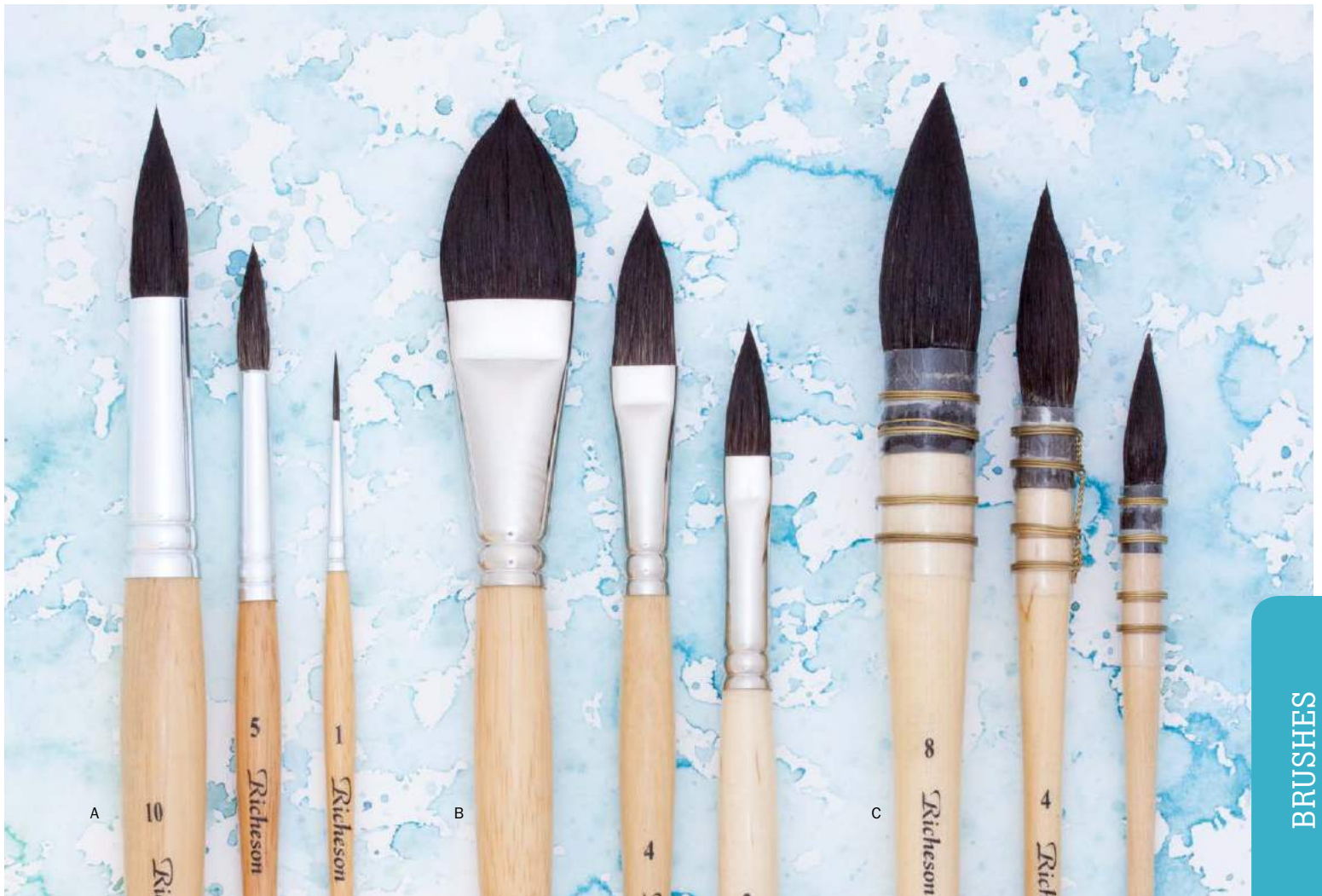

BRUSHES

## A. Series 2040 Black Squirrel Short Handle

This brush has truly been missing from the marketplace for years. Black Squirrel has been called the perfect watercolor tool. It is softer than Sable, points as well, holds more liquid and is easy to control. As it releases color, it loses some of its snap, so consequently it is better to use with a wet technique. Although less expensive than Sable, it is considered by many to be a better brush.

NUMBER	YARKA SIZE	ENGLISH SIZE
20401	1	1
20402	2	2
20403	3	4
20404	4	6
20405	5	8
20406	6	10
20407	7	12
20408	8	14
20409	9	15
20410	10	16

## B. Squirrel Sky Wash Brush Short Handle

Truly a magnificent watercolor tool! A flat oval squirrel brush that comes to a fantastic point. No other hair can perform as well as squirrel in this shape. The brush can be used as a three sided brush. You have the broad flat, the long thin side and the fine point. Every painter will fall in love with this great brush. Available in 4 sizes.

NUMBER	SIZE	DIAMETER
20602	2	1/4"
20604	4	1/2"
20606	6	3/4"
20608	8	1"

2040 Round Series Size Chart

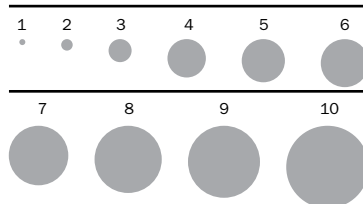

## C. Squirrel Classic Mop Brush Short Handle

If you're old enough, you will remember this brush from before World War II. Made of Pure Black Kazan Squirrel hair, it has the shape of a large round brush when wet. Originally these brushes were made with quills of large sea birds for ferrules. Today we use plastic with wire to bind them. The brush is a real treat to use.

NUMBER	SIZE	DIAMETER
20612	2	1/4"
20614	4	1/2"
20616	6	3/4"
20618	8	1"

# PROFESSIONAL SYNTHETIC WATER MEDIA BRUSHES

BRUSHES

20

1.800.233.2404



Painting by Stephen Quiller  
[www.quillergallery.com](http://www.quillergallery.com)



Artist Stephen Quiller is an internationally known painter who works primarily in water media, monotypes, and intaglio printmaking. He is best known for his innovative approach to water media painting: watercolor, gouche, acrylic, casein and their combinations, and for his use of color. He has written six books, all published by Watson-Guption.

His research and development of a color wheel for painters called the "Quiller Wheel" is now used by thousands of painters throughout the world.

# QUILLER WATER MEDIA BRUSHES

## Water Media Brushes

Pure Sable or Kolinsky is the finest way to make a watercolor brush. Coming up second is a hi-tech fiber and production method that rivals some of the finest Sable Brushes. 25 years ago, nylon or other synthetic fibers would only make a fair student brush. Today with advanced technology we can achieve a brush that almost matches the finest Sables.

The 7000 Series is our current generation of advanced synthetic brushes. To design this 21st century brush we enlisted the aid of a renowned water media painter, Steve Quiller.

We have tapered the strands of fiber so that each strand comes to a fine point. With careful selection of 11 different weights of fiber strands we can gently mix these into a marvelous brush head. The mixing of the weights is critical. With just the right amount of thicker fiber you can achieve the ideal amount of hard snap to the brush. With the perfect mixture of a variety of thinner fibers we arrive at the perfect color carrying blend.

## 7000 Quiller Round Series Short Handle

In selecting the perfect synthetic round brush, it must have a firm needle point, a body that will carry a large load of color and last, but very important, a body that will allow the color to gently release and not flood out on the paper.

This brush has a beautiful gold seamless ferrule and is mounted on a classic matte black handle.

NUMBER	SIZE
700055	3/0
700044	2/0
700000	0
700001	1
700002	2
700003	3
700004	4
700005	5
700006	6
700007	7
700008	8
700010	10
700012	12
700024	24

**Assortment** shown on page 50.  
Number 995040

## 7010 Quiller Flat Series Short Handle

When wet, these flats come to a magnificent razor's edge, allowing the thinnest line, a broad wash or anything in between. The ferrules on the 7010 flats have a round base up to the 1" size and the larger sizes have a folded flat base.

Steve works very big and was really pleased when we developed a brush that could hold so much color and retain the control. You won't believe the edge!

NUMBER	SIZE
701000	1/8"
701005	3/16"
701025	1/4"
701050	1/2"
701075	3/4"
701010	1"
701051	1-1/2"
701020	2"

7000 Round Series Size Chart

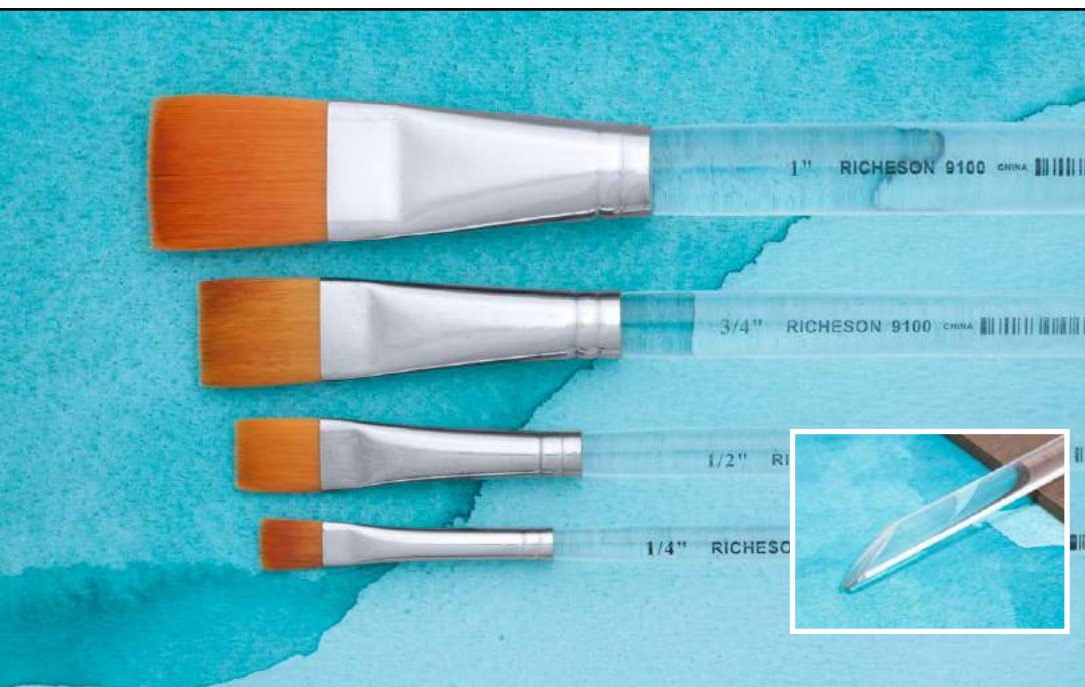
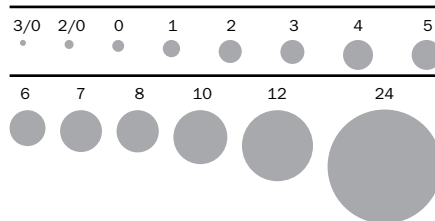

## 9100 Flat Aquarelle

An essential to many painters, the aquarelle brush has a short, clear acrylic handle cut on an angle to create a long oval scraper on the end – an excellent tool for cutting lines through color. The brush head is made with top quality synthetic fiber.

NUMBER	SIZE
910025	1/4"
910050	1/2"
910075	3/4"
910010	1"

**Assortment** shown on page 50.  
Number 995038

# 9000 SERIES WATERCOLOR BRUSHES

Years ago, when we first introduced the market to the fabulous "9000" brushes, they were a whole new way of making brushes. Its historic fine snappy point and its ability to carry great volumes of color have kept it an industry leader.

These brushes have seven different types of pointed synthetic fibers blended to create a marvelous artist tool. The brushes have a silver seamless ferrule and a beautiful black handle with gold and yellow trim. The ferrules on the 9010 flat are a round base up to 1" and the larger sizes are a folded flat base.



## Synthetic 9000 Round Series Short Handle

These short handled rounds will hold plenty of watercolor, gouache, casein or acrylic, and release paint smoothly, giving the painter perfect control.

NUMBER	SIZE
900066	4/0
900055	3/0
900044	2/0
900000	0
900001	1
900002	2
900003	3
900004	4
900005	5
900006	6
900008	8
900010	10
900012	12
900014	14
900016	16
900020	20
900024	24

## Synthetic 9010 Flat Series Short Handle

Flats are becoming more important all the time for the serious watercolor painter. These brushes are made very full with the ability to carry a great deal of liquid, yet still not flood out all over your work. These brushes come to a razor edge for fine lines or cut-in work.

NUMBER	SIZE
901000	1/8"
901005	3/16"
901025	1/4"
901050	1/2"
901075	3/4"
901010	1"
901051	1-1/2"
901020	2"
901030	3"
901040	4"

**Assortment** shown on page 50.  
Number 995041

## The Liner Brush - 9020 Short Handle

A good liner must have tremendous snap and maximum control for long flowing lines. This brush has great strength and good color-carrying capacity. Our 9020 is the Best of the Best when it comes to liners.

NUMBER	SIZE
902050	50/0
902000	0
902001	1
902002	2
902003	3

\*Not available in an assortment.

9000 Round Series Size Chart

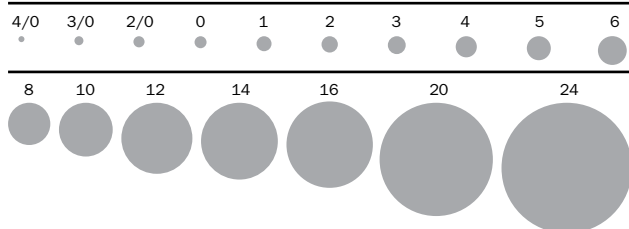

9020 Liner Series Size Chart

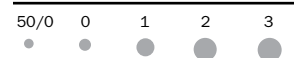

# 8000 SERIES WATERCOLOR BRUSHES

The "8000" series offers a tool that gives the beginner a chance to enjoy the world of creativity while meeting the frugal needs of University Students. It is a blend of two diameters of synthetic fiber making a very impressive quality watercolor brush. This is a series that gives the best of both worlds... great quality and a great price!



## White Synthetic 8000 Round Series Short Handle

These rounds are full bodied and come to a needle point.

NUMBER	SIZE
800055	3/0
800044	2/0
800000	0
800001	1
800002	2
800003	3
800004	4
800005	5
800006	6
800008	8
800010	10
800012	12
800014	14

## White Synthetic 8010 Flat Series Short Handle

This series has been designed to give the student a good chance at success in a difficult medium. The brush is quite full when dry and forms a nice edge when wet.

NUMBER	SIZE
801025	1/4"
801050	1/2"
801075	3/4"
801010	1"
801051	1-1/2"

**Assortment** shown on page 50.  
Number 995038

## White Synthetic Set of 5

Includes rounds sizes 4, 6, 8 and flat sizes 1/2" and 3/4". Packaged in a clear poly bag – great for classes!

**NUMBER 801090**

8000 Round Series Size Chart

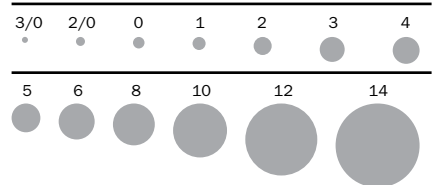

## White Synthetic Long Liners Short Handle

Economical, great quality synthetic liner with a beautiful snap and point.

NUMBER	SIZE
970488	6/0
970444	2/0
970401	1
970402	2
970404	4
970406	6

9704 Liner Series Size Chart

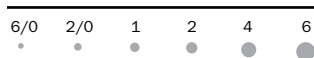

# SZABO WATERCOLOR BRUSHES



Born in Hungary, Zoltan Szabo emigrated as a young man fleeing Communism before the Hungarian Revolution.

Zoltan developed techniques that were exceptional to his style of painting and taught workshops across North America. Many Zoltan devotees continue to teach those techniques to students worldwide.

The Richeson School of Art & Gallery is honored to be the home of Zoltan's North America Series. Prior to his death, Zoltan committed to paint a piece for each state in the U.S. and each province in Canada. Although he was unable to complete the series prior to his passing, the Richeson School of Art & Gallery is the proud owner of 43 of these magnificent paintings. This is the largest collection of Zoltan works on display in one location. They can be seen in our gallery in Kimberly, Wisconsin.

## Zoltan's Bristle Slant Short Handle

A brilliant idea. A stiff bristle brush built with a slant for special watercolor techniques. It's perfect for laying in a background or a big sky. The design allows you to use the pointed end of the slant to pick up color from your palette and just lay it in across your paper. Using the whole width wet, you can flow a sky or a background in a beautiful graded wash.

NUMBER	WIDTH	LENGTH
915220	1"	1"
915260	1-1/2"	1-1/32"
915280	2"	1-1/16"
915290	3"	1-1/8"
915295	4"	1-3/16"

\*No assortments available.



On display at the Richeson School of Art

BRUSHES

24

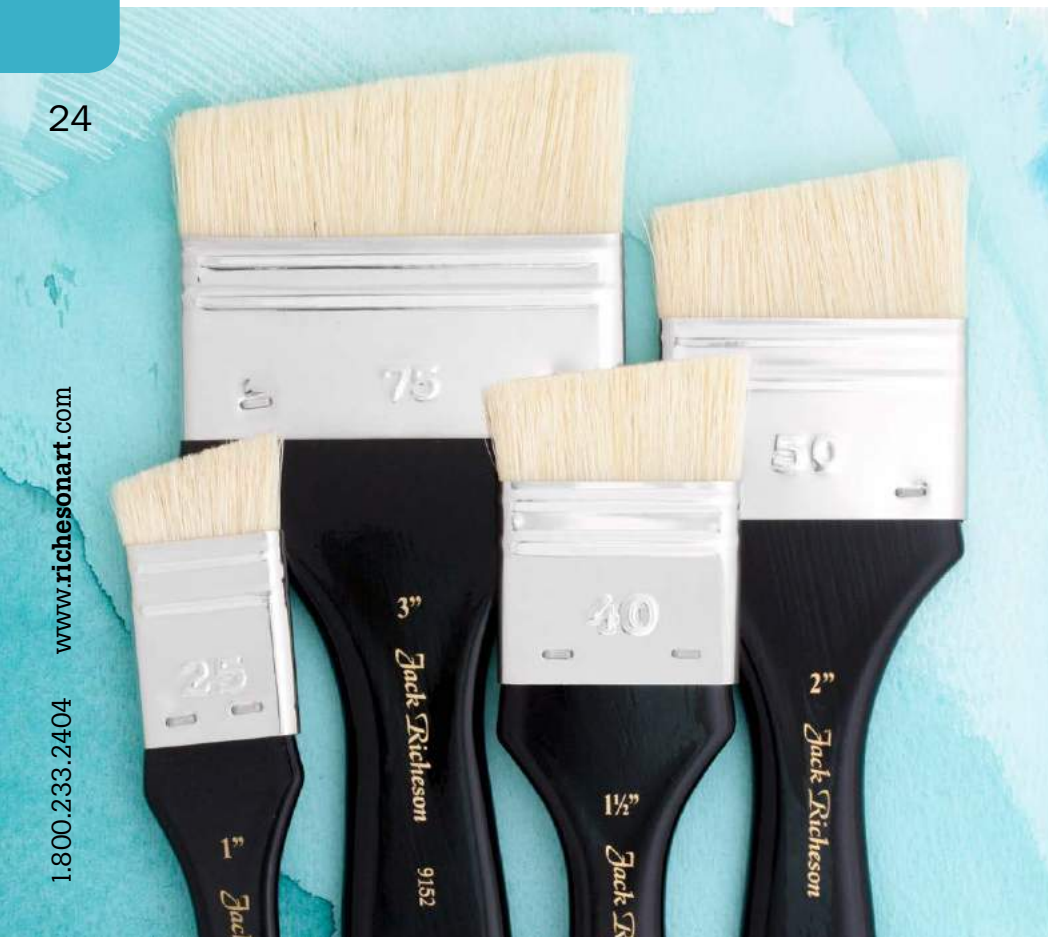

www.richesonart.com

1.800.233.2404



# CHINESE WATERCOLOR BRUSHES

## Chinese Watercolor Brushes

Chinese brushes were originally designed as writing instruments. It was the West that discovered many uses for them as fine art tools. The types and uses of animal hair is very different in China than it is in Europe. The numbering of Chinese calligraphy brushes is also different.



### A. White Goat Calligraphy Brush 5113 Series

Number 1 is largest, number 6 is smallest. A beautiful brush series. This brush works well for watercolor and points very well. It has a beautiful appearance with a very unique ornate handle.

NUMBER	SIZE	NUMBER	SIZE
511301	1"	511302	2"
511303	3"	511304	4"
511305	5"	511306	6"

### B. Chinese Soft Rabbit Watercolor Brush 5214 Series

Number 1 is largest, number 3 is smallest. Probably the greatest student brush ever made. This brush is made with soft rabbit hair and it holds color well. It comes to a fantastic point when wet and has a very plain bamboo handle.

NUMBER	SIZE	NUMBER	SIZE
521401	1"	521402	2"
521403	3"		

### C. Chinese Soft Rabbit Watercolor Brush 5210 Series

Number 1 is largest, number 3 is smallest. This brush is very similar to the 5214 described above except that it is a slightly better quality and it has a more ornate handle.

NUMBER	SIZE	NUMBER	SIZE
521001	1"	521002	2"
521003	3"		

\*No assortments available.

5113 Round Series Size Chart

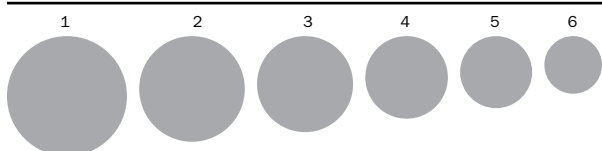

5214 Series Size Chart



5210 Series Size Chart



### D. Hake Brushes 5103 Series Long Handle Flats

100% wool hake brush. Ideal for watercolor and work with dye. The brush head is sewn into a beautiful unfinished wooden handle.

NUMBER	SIZE	NUMBER	SIZE
510301	1"	510304	2-1/2"
510302	1-1/2"	510305	3"
510303	2"	510306	4"

### 510307 Set of 3

Contains brushes 5103101, 510302, and 510303.



### E. The Silk Brush 5130 Series Short Handle Flats

An inexpensive soft bristle brush that is ideal for many watercolor techniques. Great for wet on wet work. Because of the soft bristle, this brush is not good for dry brush effects but it is marvelous for silk painting or other wet techniques.

NUMBER	SIZE
513001	1-1/8"
513002	1-1/2"
513003	2"
513004	2-1/4"
513005	2-3/4"
513006	3"



# CHINESE BAMBOO BRUSHES

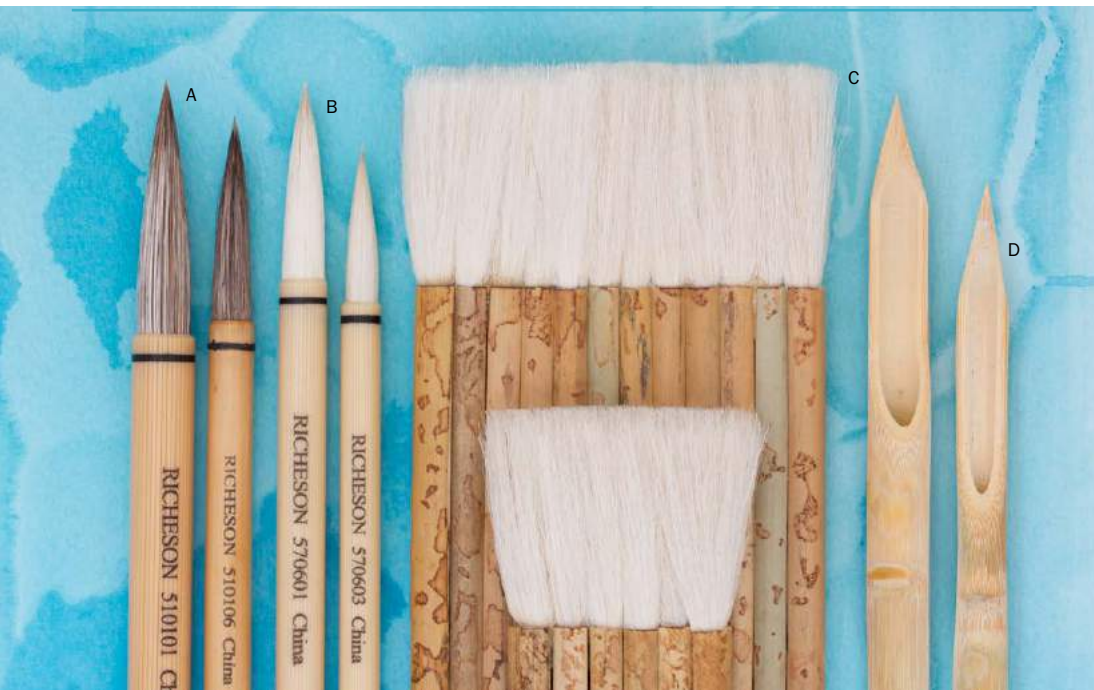

## A. Traditional Chinese Brushes 5101 Series

Number 1 is largest, number 6 is smallest. If an artist is familiar with a Chinese Brush, the chances are that it is this style. Designed originally for lettering, the original concept is that only the tip is used when applying color. Made with horse hair. The handle is plastic, traditional bamboo-like in appearance.

NUMBER	SIZE	NUMBER	SIZE
510101	1	510104	4
510102	2	510105	5
510103	3	510106	6

### Set of 5 510107

Contains one of each size 1-5 of series 5101

### Set of 5 510109

Contains 510103, 521403, 511305, 524103, 570602

## B. White Horse Hair Brushes 5706 Series

Number 1 is largest, number 3 is smallest. The brush works almost the same as the 5101 but aesthetically is more attractive as well as more expensive. The handle is plastic, traditional bamboo-like in appearance.

NUMBER	SIZE
570601	1
570602	2
570603	3

\*No assortment.

5101 Round Series Size Chart

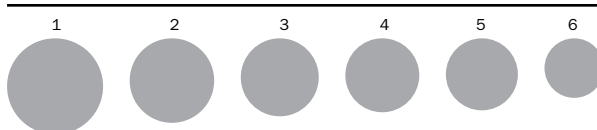

## C. Multi Head Bamboo Brush 5242 Series

These are bamboo brushes that have a unique ferrule that bonds a series of wool heads together. These brushes are marvelous for different watercolor techniques.

NUMBER	SIZE	WIDTH	HAIR LENGTH
524206	6	2"	2-1/2"
524212	12	4"	2-1/2"
524214	14	4-1/2"	2-1/2"
524216	16	5-1/2"	2-1/2"

## D. Bamboo Reed Pens

These old world tools can bring a new look to anyone's work. Used for writing or adding lines or detail to artwork. Polybagged.

NUMBER	DESCRIPTION
210520	Small
210521	Medium
210522	Large
210523	Set of 3 (S, M, L)

# BRUSH HEAD SHAPES – WHAT DO THEY MEAN?

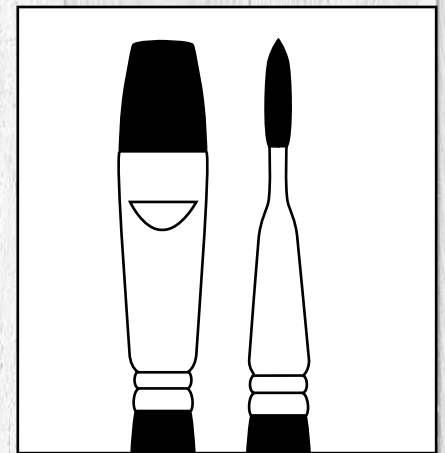

Oil/Acrylic Bright Head      Fibert Head Side View

A good quality bright brush meant for painting with oil & acrylic requires a full bodied head that comes to a razor edge.

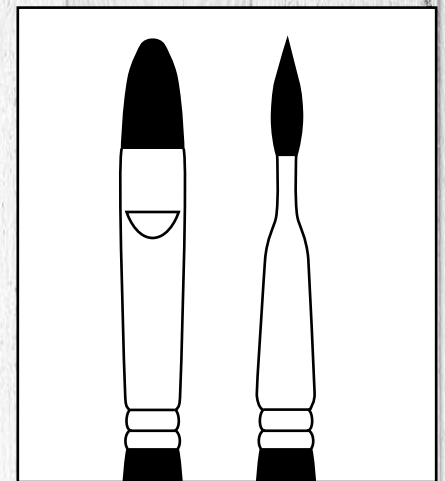

Oil/Acrylic Fibert Head      Watercolor Head

A good quality fibert brush requires a full bodied head that comes to a thin edge.

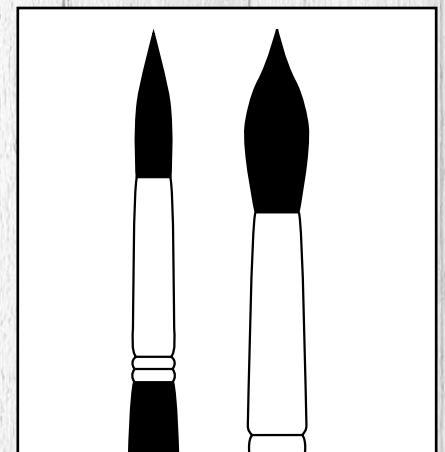

Oil/Acrylic Head      Watercolor Head

Painting with oil & acrylic requires a firmer brush head than a watercolor brush.

# WHAT MAKES A QUALITY OIL & ACRYLIC BRUSH?

## Brushes of the Old Masters

Bristle brushes are where painting began. The Old Masters used only rounds. Flats weren't developed until the nineteenth century. Sable and other forms of soft hair brushes were unheard of. The painter would use a new bristle tied at the head to form a round brush. He would use this until the bristle became soft, then he would remake the soft bristle into his detail brushes. It was the soft bristle that was always used for glazing. Even back then, they understood what made a quality brush.

## Two things determine brush quality and price: materials and workmanship.

Bristle from hogs that have been fed additives and have been kept in heat controlled environments may make great pork, but they make terrible bristle. It is cheap, weak and makes for equally terrible brushes. Hogs living outdoors in freezing climates grow tremendous long bristle. Usually, these hogs have a poor diet... just what is required for good bristles. With the industrialization of farming throughout the world, the best bristle for brushes is getting harder to find and becoming more expensive. The cold, undeveloped provinces of China and Russia produce the finest bristle in the world.

## FERRULES AND HANDLES ARE IMPORTANT

not only for cosmetics, but also for structure. The handles of high end brushes are designed to reduce fatigue while painting. The balance is carefully tested and the weight is always of great concern.

Workmanship is critical. For the highest quality, you should always insist on handmade brushes. These brushes feature carefully selected and graded materials that are skillfully assembled by conscientious crafts people. Each brush must meet stringent specifications.

## The Importance of True "Interlocked" Construction

The word interlocked is thrown around rather carelessly. What does it mean? All bristle has a natural curve. In good brushes, all the bristles are sorted by size and faced in the same direction. Hair bundles are made and placed in the ferrules in opposite directions. This interlocked construction creates a brush that is firm, responsive and one that resists spreading of bristles and losing its shape.

When going to the expense of creating an interlocked brush you must use the finest Chinese Bristle. When selecting the hair, care is taken in separating sizes as bristle may never be cut or trimmed when making a good brush.

In fine bristle, the ends are very soft and many times split. This is called "Flagging", and it is these soft ends that make the brush really good. In cheap brushes, machines stack and trim the bristle to make them look good and uniform. In making a quality brush, however, no cutting is ever used. (See photo on previous page.)

## The Evolution of Brush Shapes

Until the nineteenth century, we had only Rounds, and to this day they are the most important shape. With the Industrial Revolution, flats, brights and filberts arrived, giving the artist a new range of tools. This had a great impact on the style of work produced.

## Why Brights?

Brights are short flats. They won't hold as much color as a flat but they are easier to control. Flats are longer and they carry more color and they apply color with more sensitivity. Manufacturers then developed filberts, or flats with rounded corners. Rounds, flats, brights and filberts became the range that fit the bill until the late 1800's.

## What is an Egbert?

During a painting class in France, an instructor was trying desperately to loosen up the style of an already accomplished painter. The man's work had deteriorated from fresh to flat. Using the bristle from a very large brush, he created a new, extra long filbert brush. This brush was almost impossible to control, forcing the artist to loosen up. The teacher named this an "Egbert". They are a tremendous exercise tool.

## Summary of head shapes for brushes

**ROUND** – This is the original brush shape, and still an important tool.

**FLAT** – This is a flat brush that has longer hair out. It carries more paint but is harder to control.

**BRIGHT** – This is a flat brush with less hair out. It carries less paint but is easier to control. Better for a beginner.

**FILBERT** – This is a flat that has been built with rounded edges.

**EGBERT (CAT'S TONGUE)** – An extra long filbert.

**FAN** – The great natural blender.



# PURE BRISTLE PROFESSIONAL SIGNATURE BRUSHES

Jack Richeson's "Signature" line of brushes is truly the finest in the world. "Signature" brushes are hand-made with quality, interlocked bristle set in polished, seamless ferrules and carefully fitted to long, black lacquered handles.

BRUSHES



28

## Signature Round Brushes 9617 Series

NUMBER	SIZE
961701	1
961702	2
961703	3
961704	4
961705	5
961706	6
961708	8
961710	10
961712	12
961716	16
961720	20

9617 Round Series Size Chart

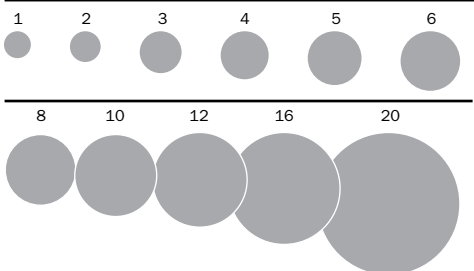

## Signature Flat Brushes 9628 Series

NUMBER	SIZE
962801	1
962802	2
962803	3
962804	4
962805	5
962806	6
962808	8
962810	10
962812	12
962816	16
962820	20

9628 Flat, 9627 Bright and 9626 Filbert Series Size Chart



## Signature Brights 9627 Series

NUMBER	SIZE
962701	1
962702	2
962703	3
962704	4
962705	5
962706	6
962708	8
962710	10
962712	12
962716	16
962720	20

# PURE BRISTLE PROFESSIONAL SIGNATURE BRUSHES

*Superior  
Interlocked  
Construction!*



BRUSHES

## Signature Fans 9640 Series

This popular bristle fan is ideal for blending oils and acrylics.

NUMBER	SIZE
964002	2
964004	4
964006	6
964008	8

## Signature Filberts 9626 Series

NUMBER	SIZE
962601	1
962602	2
962603	3
962604	4
962605	5
962606	6
962608	8
962610	10
962612	12
962616	16
962620	20

## Signature Egberts 9629 Series

NUMBER	SIZE
962902	2
962904	4
962906	6
962908	8
962910	10
962912	12

29

**Assortment** shown on page 51.  
Number 995036

9640 Fan Series Size Chart



9629 Egbert Series Size Chart



# CHELVESTON BRISTLE BRUSHES

Named after an area in England that saw the birth of many great painters, this is the line we market as our middle range. Using the same fine interlocked bristle as our top line, great attention is given to forming the brush heads. The flagging is excellent and the head shapes are designed to give the maximum life to the brush. The ferrules are a beautiful, highly polished copper nickel and the handles have excellent balance and are designed to reduce fatigue.



## Chelveston Round Brushes 9017 Series

NUMBER	SIZE
901701	1
901702	2
901703	3
901704	4
901705	5
901706	6
901708	8
901710	10
901712	12

9017 Round Series Size Chart

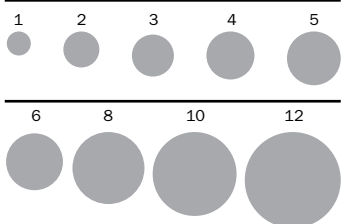

## Chelveston Flat Brushes 9028 Series

NUMBER	SIZE
902801	1
902802	2
902803	3
902804	4
902805	5
902806	6
902808	8
902810	10
902812	12

9028 Flat, 9027 Bright and 9026 Filbert Series Size Chart

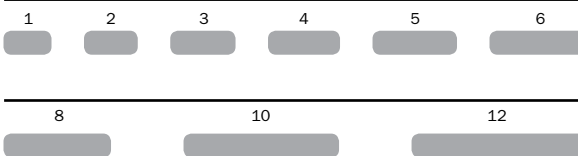

## Chelveston Bright Brushes 9027 Series

NUMBER	SIZE
902701	1
902702	2
902703	3
902704	4
902705	5
902706	6
902708	8
902710	10
902712	12

# CHELVESTON BRISTLE BRUSHES



## **Chelveston Egbert Brushes 9029 Series**

NUMBER	SIZE
902902	2
902904	4
902906	6
902908	8

## **Chelveston Filbert Brushes 9026 Series**

NUMBER	SIZE
902601	1
902602	2
902603	3
902604	4
902605	5
902606	6
902608	8
902610	10
902612	12

## **Chelveston Fans 9240 Series**

NUMBER	SIZE
924002	2
924004	4
924006	6
924008	8



Painting by Albert Handell  
www.alberthandell.com

**Assortment** shown on page 51.  
Number 995035

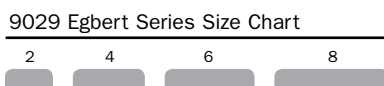

9240 Fan Series Size Chart



# STUDENT BRISTLE BRUSHES

## Student Bristle Round Series 9582 and Flat Series 9579 Brushes

These brushes are made of pure Chungking hog bristle, naturally tapering, with a deeply flagged tip that spreads lots of thick or heavy paint evenly on a board or canvas. Brush heads are hand-cupped in seamless glistening ferrules and set on well-shaped wooden handles. This series is economically-priced and offers rugged performance to students learning to paint with oils and acrylics.



### A. Round Series - 9582 Long Handle

NUMBER	SIZE
958201	1
958202	2
958203	3
958204	4
958205	5
958206	6
958207	7
958208	8
958209	9
958210	10
958211	11
958212	12

### B. Flat Series - 9579 Long Handle

NUMBER	SIZE
957901	1
957902	2
957903	3
957904	4
957905	5
957906	6
957907	7
957908	8
957909	9
957910	10
957911	11
957912	12

### C. School Easel Brush - 9151 Long Handle

This natural wood handled brush is made with select black bristle.

NUMBER	SIZE
915102	1/4"
915104	1/2"
915106	3/4"
915108	1"

\*No assortment available.

Assortment shown on page 52.  
Number 995032

9579 Flat Series Size Chart

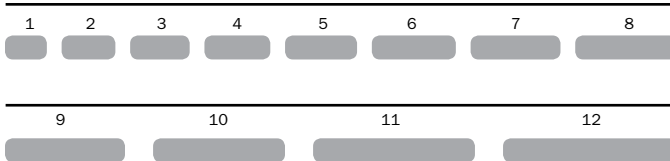

9582 Round Series Size Chart

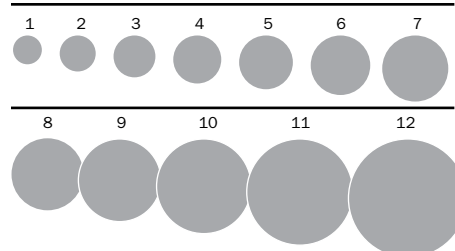



# SPALTER BRUSHES

## What are Spalters?

Brushes designed specifically for large canvases (spalters) were created to permit working from a greater distance without sacrificing control and finesse. Brushes for the needs of fresco painters, who had to cover large, often abrasive surfaces, were also created.

The wear and tear on fresco brushes demanded that they be economical, and the distance required of spalters demanded fine balance and control. These brushes are also fantastic for those working on Theater Scenery. Whether working in acrylics, tempera, watercolors, or oils, these brushes will more than please the most demanding painter.

### A. English Spalter - 9420 Long Wooden Handle

This long handled brush is somewhat stiff and firm due to the short bristle length. Great for background painting. Available in 3 sizes.

NUMBER	SIZE	HANDLE LENGTH
942001	1"	9-7/8"
942002	2"	10-1/4"
942003	3"	10-1/8"

### B. Soft Spalter - 9155 Long Wooden Handle

An excellent soft bristle brush for blending.

NUMBER	SIZE	HANDLE LENGTH
915501	1-1/8"	9-1/2"
915502	1-5/8"	10-1/2"
915503	2"	11"
915504	2-3/8"	12-1/8"
915506	3-1/8"	13"

### C. Bristle Chip Brushes Short Handle

Natural white bristle brushes that are perfect for working with large areas of rubber cement or gesso. All wood handle.

NUMBER	SIZE
515005	1/2"
515010	1"
515015	1-1/2"
515020	2"
515025	2-1/2"
515030	3"



# FRESCO AND GESSO BRUSHES



**A. Flat Fresco Varnish Brushes - 9537 Short Handle**

Italian house painting brushes make the finest flat fresco or scenery brushes. We have selected the very finest of pure bristle brushes. These are thick, full-bodied brushes with a wooden handle.

NUMBER	SIZE
953720	3/4"
953740	1-1/2"
953760	2-3/8"
953780	3-1/8"

**B. Economy Flat Gesso - 9211 Short Handle**

This brush is made with a metal ferrule and a plastic handle. They can be used with oil paint as well as acrylics. These brushes make an excellent gesso brush as the bristle is firm and is strong enough to move heavy gesso around.

NUMBER	SIZE
921120	3/4"
921160	2-3/8"
921140	1-1/2"
921161	Set/3

**C. Oval Fresco Brushes - 9129 Short Handle**

This is a great scenery brush. Made of pure bristle, it has a wood handle. The head is a thick oval-based shape with a large oval silhouette. The handle is extremely important for set designers. Because their work is so large and the color load so heavy, a poorly made handle can cause blisters. The handle is comfortable even after many hours work.

NUMBER	SIZE
912910	1-1/2"
912914	2"
912918	2-1/2"

**D. Synthetic Gesso - 9158 Brushes Short Handle**

Modern manufacturing techniques make this affordable synthetic brush a great option to gesso areas large or small. Synthetic Gesso Brushes have specific appeal when working broad areas in acrylic.

NUMBER	SIZE
915801	1"
915802	2"
915803	3"

**Did You Know?**

The word "fresco" comes from the Italian word for "fresh." There are two types of true fresco painting. In buon, or pure, fresco, the paint is applied to a wet, or fresh, layer of plaster. The pigments used in these paintings form a permanent chemical bond with the wall surface when dry.

The other type of fresco painting is called secco, or dry, in which the paint is bonded to the wall with adhesive binder flakes. This type of fresco, however, is not permanent. Fresco painting was highly popular during the Renaissance period. Today, true fresco is rarely used due to its susceptibility to humidity and weathering.

# ITALIAN SASH BRUSHES



## Sash Brushes

When we look at art history we find that the early Old Masters had only one style of brush. They all used bristle rounds. Da Vinci, Michelangelo and the Dutch Greats used softened bristle wrapped around a stick.

They worked and re-worked the shape and in doing so they softened the bristle. For the true landscape painter, a real treat is in store when he or she purchases an Italian Sash Brush. The head is almost identical to those once used by the "Greats".

To work a large painting with one of these is a real treat. There are two different shaped heads, one is bullet shaped and one is domed. Both are marvelous painting tools and very inexpensive.

## Domed Sash Brushes

This style is the closest to that used in the 1500's. Its thick bristle build carries a tremendous load of paint while providing good control. Any landscape painter or set designer will love the way that it works.

The bristle is held in place in a brass ferrule by epoxy glue. The handle is well balanced and these brushes work equally well with oils or acrylics.

### A. 9049 Long Handle

NUMBER	SIZE	DIAMETER	LENGTH
904901	0	3/4"	1-3/4"
904902	2	7/8"	1-3/4"
904903	3	1"	1-3/4"
904904	4	1-1/8"	2"
904905	5	1-1/4"	2-1/2"
904906	6	1-3/8"	2-1/2"

### B. 7152 Short Handle

NUMBER	SIZE	DIAMETER	LENGTH
715202	2/0	5/8"	1-3/4"
715220	2	7/8"	1-3/4"
715230	3	1"	1-3/4"
715240	4	1-1/8"	2"
715250	5	1-1/4"	2-1/4"
715260	6	1-3/8"	2-1/2"

## Pointed Sash Brushes

This is a marvelous addition to anyone's brush collection. The handle is designed for a good "feel" and it reduces the fatigue that follows many hours of work on a large painting.

The head on these brushes come to a sculptured fine point and work well for detail. The bristle is well packed and is held in place with an epoxy glue.

### c. 9149 Long Handle

NUMBER	SIZE	DIAMETER	LENGTH
914901	0	3/4"	1-3/4"
914902	2	7/8"	1-3/4"
914903	3	1"	1-3/4"
914904	4	1-1/8"	2"
914905	5	1-1/4"	2-1/2"
914906	6	1-3/8"	2-1/2"

### d. 7154 Short Handle

NUMBER	SIZE	DIAMETER	LENGTH
715402	2/0	5/8"	1-3/4"
715420	2	7/8"	1-3/4"
715430	3	1"	1-3/4"
715440	4	1-1/8"	2"
715450	5	1-1/4"	2-1/4"
715460	6	1-3/8"	2-1/2"

Assortment shown on page 51.  
Number 995033

# SOFT HAIR OIL & ACRYLIC BRUSHES



Painting by Jeff Hargreaves  
www.jeffhargreaves.com

## Oil & Acrylic Brushes

Soft hair brushes are relatively new to the Western world. It wasn't until about 1850 that soft hair brushes started appearing in Europe. It was about the same time that the first brush manufacturers started their businesses.

The first hair to be seen was horse, pony, wolf and then sable. Soon after, domestic animals such as ox were brought into the business. Over the years, other hair types have come and gone, civet cat, fitch and mongoose. The favorite and most reliable remains sable.

## Kolinsky Sable

Only selected triple-dressed tails from the male Marten weasel are used in these brushes. Very expensive, but without a doubt it is the best natural hair available for professional artist's brushes. When properly cared for, a Kolinsky brush will last for years. You can care for your Kolinsky by not using it on rough surfaces and cleaning it with a good brush cleaner and conditioner.

## Sable

It's important to learn the merits of different hair. Sable, from the Marten weasel, is a hair that comes from the tail of the weasel. Each hair has a belly that then slopes to a needle point. It is this

belly and point that determine the quality of the brush when in the hands of a qualified brush maker.

It is critical that the belly of the brush is just above the ferrule opening. A brush maker trying to improve his profits will bring the hair out too far to make it look larger. The result is a big brush that will not work and a bargain hunter who cannot paint.

The importance of the length of the hair out of the ferrule is strength. When painting with thick oils or acrylics, you will be pushing and pulling heavy paste and you will need a strong brush to accomplish this well. Sable remains the best product for this task.

## Ox Hair

Ox hair is a beautiful hair for flat brushes. It does not do well for rounds as each hair has a blunt tip. Ox hair comes from the hair around the animal's ear. The animal is not injured; the hair is trimmed in much the same manner as a barber does to a man's hair. The result is that there are no points. Some fine ox hair can be used in one stroke brushes.

## Fitch Hair

Real fitch hair disappeared years ago. Rarely will enough surface to make a few brushes. Most fitch hair on the market is actually pony or a combination of horse and goat.

## Synthetic Fiber

A tremendous change came to the Art Industry in the 30's. Acrylic paint and advances by industry leaders made a great technical change in painting. With change came the need for new types of brushes.

It wasn't until the mid-fifties that the need was really addressed. Synthetic fiber brushes started to surface. The first were nothing more than bundles of blunt fishing line chopped up and stuck on a stick.

The technical advances continued through the sixties, seventies and eighties. Each generation brought us a better and better substitute for natural hair and always at greater savings to the user. Today there are some synthetic fibers that almost equal fine sable at a fraction of the price.

With these great advances, new problems are created for the student painter. There are a hundred different kinds of mixes and blends with various types of synthetics and nylons. Don't believe that they are all the same. A brush that is made of 50% sable and 50% synthetic is miles better than a brush made with 92% synthetic and 8% sable.

Some of the new synthetic fibers, when mixed with fibers of different weights are just fabulous.

# KOLINSKY SABLE OIL BRUSHES

## Professional Kolinsky Sable Oil Brush Series

Very few companies today manufacture a pure Kolinsky Sable Brush for oils. Hair for this brush comes from the most Northern areas of the Kolin Peninsula and is most difficult to trap. It is the finest and the most expensive hair used in brush making.

When using hair of this quality we use only the finest and most skilled brush makers. The brush is mounted in a gold ferrule and has a beautiful walnut handle.

### Kolinsky Round 7162 Long Handle

The round is a very difficult brush to make correctly. You can not use a watercolor head on a long handle to get a good oil or acrylic brush. In watercolor, you are pushing very thin applications of colored water. Because there is very little resistance, you need a full bodied brush with great snap but little muscle. With oils and acrylics you will be pushing very thick applications of heavy paste like paint. Here muscle is required.

NUMBER	SIZE
716202	2
716204	4
716206	6
716208	8
716210	10
716212	12
716216	16
716220	20
716224	24

### Kolinsky Flat 7163 Long Handle

This flat brush is full and lush and comes to a razor edge.

NUMBER	SIZE
716302	2
716304	4
716306	6
716308	8
716310	10
716312	12
716316	16
716320	20
716324	24

### Kolinsky Filbert 7160 Long Handle

The shape of the filbert is achieved by gently moving the hair in the finger tips of the brush maker to achieve that perfect oval shape. A knife can never touch the hair, the tips are never cut or trimmed.

NUMBER	SIZE
716002	2
716004	4
716006	6
716008	8
716010	10
716012	12
716016	16
716020	20
716024	24

### Kolinsky Bright 7161 Long Handle

This brush is full bodied and comes to a razor edge.

NUMBER	SIZE
716102	2
716104	4
716106	6
716108	8
716110	10
716112	12
716116	16
716120	20
716124	24

Assortment shown  
on page 52.  
Number 995044

7160 Filbert , 7161 Bright and 7163 Flat Series Size Chart

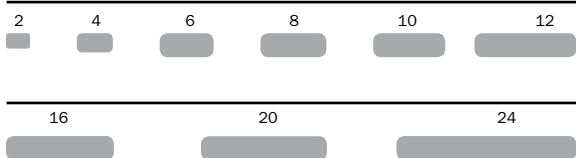

7162 Round Series Chart

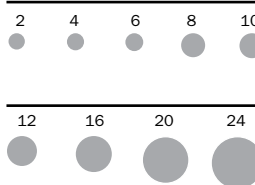

# RED SABLE OIL BRUSHES

Pure Red Sable has been the soft hair brush of choice for many years. Real red sable comes from the tail of the marten weasel. In the U.S., everything from top sable to rat hair is used in brushes and called sable – it's a buyer beware market. Our red sable brushes are pure red sable. They are not hidden in cellophane or strapped to a board. Know what you expect from a brush and then make the dealer let you test the brush. A good shop will have water available and let you test several brushes.

BRUSHES

38



## Pure Sable Rounds - 9117 Long Handle

The head of this brush is somewhat stout so that it will manhandle the heavy loads of oils or acrylics. The head comes to a fine but firm point and is excellent for detail.

NUMBER	SIZE	NUMBER	SIZE
911701	1	911702	2
911703	3	911704	4
911706	6	911708	8
911710	10	911712	12
911714	14		

9117 Round Size Chart

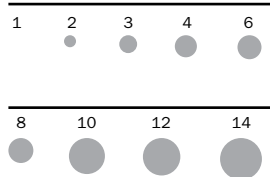

## Pure Sable Brights - 9160 Long Handle

Our bright is hand crafted by master brush makers using the finest pure red sable. The brush is full bodied and comes to a razor edge.

NUMBER	SIZE	NUMBER	SIZE
916001	1	916002	2
916003	3	916004	4
916006	6	916008	8
916010	10	916012	12

9160 Bright Size Chart

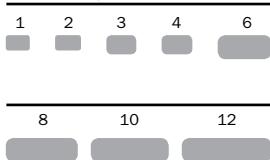

## Pure Sable Filberts - 9161 Long Handle

Our filbert is full bodied and comes to a razor edge. Few filberts on the market will hold the edge that this brush does.

NUMBER	SIZE	NUMBER	SIZE
916102	2	916104	4
916106	6	916108	8
916110	10	916112	12

9161 Filbert Size Chart



Assortment shown on page 52.  
Number 995043

# UNIQUE FAN BRUSHES

A big fallacy that has developed is that you cannot use sable brushes with acrylics. Sable brushes work marvelously with acrylics.

**The key when using sable brushes with acrylics is to clean your brushes often and well!**

Acrylics are notoriously hard on brushes, but with proper care, it can be done. Don't let paint build up around the ferrule. The paint that gets underneath hardens and causes splitting.

During testing we have used sable brushes in oils, cleaned the brushes well, dried them and then used them in acrylics with no ill effects. We have reversed the procedure using acrylics first then oils and again there was no ill effect.



## Give Your Brushes a Rest

After using sable brushes for months, give them a rest. Wrap them in an old rag after first putting a few drops of "lard oil" on the tips. It returns the natural oils to the brushes much as hair conditioner does for human hair.

**Proper care and cleaning will allow you to purchase the very finest of brushes and use them for many years to come!**



Painting by Daniel Greene  
www.danielgreene.com

## Why Fans?

Shaped like a fan, these brushes are used to pull grass, fur or other strokes as well as to soften edges. They are the perfect blending tool. Natural hair is especially ideal for soft blending.

## Pure Sable Fan - 2047 Series Long Handle

The finest quality pure Sable fan available. This handmade brush works beautifully to blend the edges or create special effects.

NUMBER	SIZE
20470	2
20475	6

\*No assortment available.

2047 Fan Series Size Chart

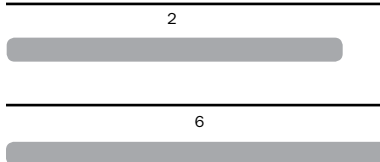

**A variety of other fan brushes found on pages 29, 31 and in an assortment on page 52.**

# ORANGE SYNTHETIC OIL & ACRYLIC BRUSHES

BRUSHES



**Assortment** shown on page 51.  
Number 995034

The fiber feels and responds like sable and it's full-bodied and carries oil or acrylic just like sable. Even loaded with paint it will come to a razor edge in the brights. The rounds are stout and come to a strong firm point. Because of their softness, they are ideal for glazing.

40

## Orange Synthetic Rounds - 9118 Long Handle

NUMBER	SIZE
911801	1
911802	2
911803	3
911804	4
911806	6
911808	8
911810	10
911812	12
911816	16
911820	20

9118 Round Size Chart

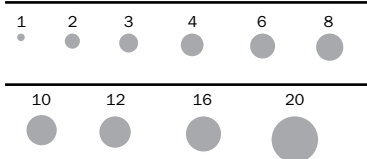

## Orange Synthetic Brights - 9164 Long Handle

NUMBER	SIZE
916401	1
916402	2
916403	3
916404	4
916406	6
916408	8
916410	10
916412	12
916416	16
916420	20

9164 Bright Size Chart

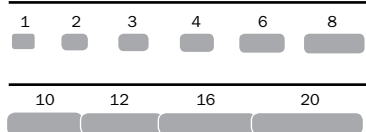

## Orange Synthetic Filberts - 9165 Long Handle

NUMBER	SIZE
916501	1
916502	2
916503	3
916504	4
916506	6
916508	8
916510	10
916512	12
916516	16
916520	20

9165 Filbert Size Chart

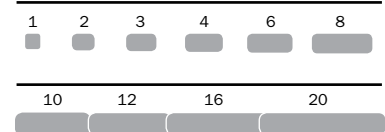



# PROFESSIONAL SYNTHETIC OIL & ACRYLIC BRUSHES



BRUSHES

The hi-tech world has developed a magnificent fiber that will take the place of bristle when working with acrylics. This new material is easier to clean, yet has all of the feel and touch of bristle. Excellent color carrying capacity in firmly designed heads that hold their shape when used vigorously.

## Professional Synthetic Rounds - 7500 Long Handle

NUMBER	SIZE
750001	1
750002	2
750003	3
750004	4
750005	5
750006	6
750008	8
750010	10
750012	12

7500 Round Size Chart

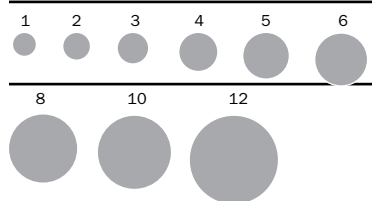

## Professional Synthetic Flats - 7530 Long Handle

NUMBER	SIZE
753001	1
753002	2
753003	3
753004	4
753005	5
753006	6
753008	8
753010	10
753012	12

7530 Flat Size Chart

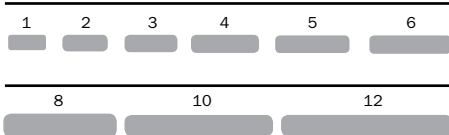

## Professional Synthetic Filberts - 7550 Long Handle

NUMBER	SIZE
755001	1
755002	2
755003	3
755004	4
755006	6
755008	8
755010	10
755012	12

**Assortment** shown on page 52.  
Number 995050

7550 Filbert Size Chart



# RICHESON'S WHITE SYNTHETIC BRUSHES



The sable-like softness of these brushes makes them ideal for smooth stroking and blending. Very affordable.

### White Synthetic Rounds - 9167 Long Handle

NUMBER	SIZE
916701	1
916702	2
916703	3
916704	4
916706	6
916708	8
916710	10
916712	12

### White Synthetic Brights - 9166 Long Handle

NUMBER	SIZE
916601	1
916602	2
916603	3
916604	4
916606	6
916608	8
916610	10
916612	12

### White Synthetic Filberts - 9168 Long Handle

NUMBER	SIZE
916801	1
916802	2
916803	3
916804	4
916806	6
916808	8
916810	10
916812	12

*Used in furniture restoration*

### Blue Synthetic Brushes

These synthetic brushes will give a more clean and more smooth sleek finish. Synthetic brushes are easier to clean and care for. Available in a variety of sizes. Short wood handle with metal ferrule. Great for a variety of different applications and techniques.

NUMBER	DESCRIPTION
953830	1"
953840	1-1/2"
953850	2"
953860	2-1/4"
953870	2-3/4"



**Assortment** shown on page 51.  
Number 995034

9167 Round Size Chart

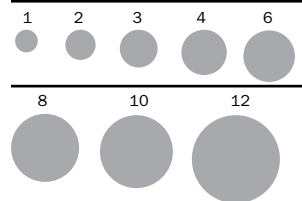

9166 Bright Size Chart

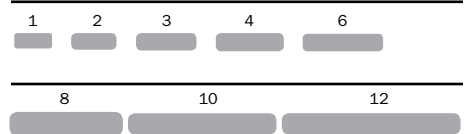

9168 Filbert Size Chart

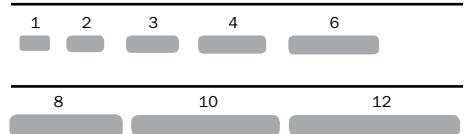

# SPECIALTY BRUSHES



## A. Waxing Brushes – 9129

Used by furniture restorers. Dispenses uniform amounts of wax or paint.

NUMBER	DESCRIPTION
912975	1-5/8" Waxing Brush
912985	2-1/8" Waxing Brush

B. 9129954-3/4" Buffing Brush

## C. Glue Brushes

These bristle hair brushes are great for bookmaking or most other craft projects. The short plastic handle will not rust, which is great when working with glues, water, and paint.

NUMBER	SIZE
582955	5/8"
582965	7/8"

## D. White Bristle Stencil Brushes

Beautiful, round shaped heads. Handles are longer than traditional stencil brushes.

NUMBER	SIZE	DIAMETER
970116	16	7/8"
970124	24	1-1/4"
970130	30	1-3/4"



## Dagger Striper – 7610

Made of pure squirrel, this has been a traditional tool for the artist. Designed in the old world style with the short rounded mini wood handle. This is the perfect tool for striping or long line work. This is the tool chosen by truck lettering artists and outdoor sign painters.

NUMBER	SIZE	NUMBER	SIZE
761000	2/0	761001	1
761002	2	761003	3
761004	4		

\*No assortment available.

### 9020 Liner Series Size Chart

50/0	0	1	2	3
•	•	•	•	•



# STENCIL BRUSHES



One of the oldest of all decorative painting techniques, stenciling is also one of the easiest to master and a perfect way of creating something original and unique.

In stenciling, paint is applied to a surface (wall, material, object...) through holes in a cut-out design on a stiff card (paper or plastic) that is sturdy enough to survive a stenciling project. For a nice clean look, use a stenciling brush and stipple paint on with a firm, punching action. Keep the brush dry and do not overload it or the paint will seep beneath the stencil.

Just about any type of paint can be used when stenciling. A lot will depend upon the surface you wish to paint on. Jack Richeson knows stencil artists need a variety brushes for their fast growing medium. We offer five different styles of brushes in a wide range of sizes, and varying degrees of stiffness. (See page 43 for more options.) Shiva brushes are a market leader and favored by artists, particularly when used in conjunction with Shiva Paintstiks.

## A. Richeson Stencil Brushes

These brushes are perfect for the stenciler requiring tight bristles. Much shorter length hair out from the ferrule results in greater control.

NUMBER	SIZE
122020	1/4"
122023	5/8"
122021	3/8"
122022	1/2"
122025	Assorted (122020-23)

## B. Shiva® Economy Stencil Brushes Series 410

Natural white bristle stencil brushes with a traditional barrel handle. Black handle, nickel ferrule.

NUMBER	SIZE
122000	1/2"
122001	1/4"
122002	3/4"
122003	1-1/4"

## C. Bristle Stencil Brushes Series 5820

This is a well-built stencil brush handmade with pure Shanghai bristle. The high-grade, flagged bristle holds color well and is flexible enough to permit beautiful shading while stenciling on furniture, walls, floors or fabric. The silver ferrule is mounted on a short raw wood handle. Available in six sizes.

NUMBER	SIZE	DIAMETER
582004	4	3/8"
582006	6	1/2"
582008	8	5/8"
582010	10	3/4"
582012	12	7/8"

\*No assortments available.



# RICHESON BRUSH SETS

## Grey Matters Travel Brush Sets

- Non-reflective bristle, ferrule and handle
- Perfect in bright sunlight or under harsh studio lights
- Neutral grey synthetic hair, ferrules and handles minimize color distortion
- Lay down the right color the first time

### A. Grey Matters Watercolor Brush Set

- Perfect for water media outdoors
- High quality synthetic
- Flat: Size 3/4"; Round: Size 4, 6, 10; Liner: Size 2

NUMBER 713996

### B. Grey Matters Oil Brush Set

- Perfect for oil painting outdoors
- Bristle and synthetic brushes
- Flat: Size 2, 6, 10; Filbert: Size 4, 8

NUMBER 713997

## Plein Air Travel Brush Sets

- Great sets for the traveling painter
- Pouch easily fits in a medium handbag or backpack
- Handle lengths are intended to be shorter than standard

### C. Watercolor Brush Set

- Perfect for water media
- High quality synthetic
- Flat: Size 1/4", 1/2", 3/4"  
Round: Size 2, 4, 6, 8

NUMBER 713995

### D. Oil Brush Set

- Perfect for oil painting while away!
- Bristle brushes
- Flat: Size 6, 10; Round: Size 4, 10; Filbert: Size 6, 12; Fan: Size 4

NUMBER 712995

### E. Sable Watercolor Assortment

This beautiful point of purchase display contains multiple sizes of one of our finest sable watercolor brushes. With a total of 312 brushes, these brushes average one dollar each for spontaneous, last minute buys. Comes with Lyptus® Wood brush holder, item 880050.

NUMBER 999800



# BRUSH SETS

These sets make excellent gifts. Jack Richeson & Co. will also make up custom sets for workshop or classroom needs. Call us at 1-800-233-2404 for information.



**A. Richeson All-Purpose Brush Sets**

These brush sets offer an amazing value! Each set has been created for a different range or type of art work. Remember, Russian sizes are larger than other brands.

NUMBER	DESCRIPTION
21102	Siberian Squirrel Watercolor Set (Includes sizes 1, 2, 3, 4, and 5 Rounds)
21101	Sable Watercolor Set (Includes sizes 1, 2, 3, 4, and 5 Rounds)

**B. Richeson Bristle Brush Sets**

Beautifully packaged bristle brush sets, one long handled, one short handled to meet any artists needs. An affordable brush packaged very attractively!

NUMBER	DESCRIPTION
915390	Set of 3 Short handle (Includes 1", 2", 3")
915490	Set of 3 Long handle (Includes 1", 2", 3")

**C. Richeson Goat Hair Brush Sets**

Beautifully packaged goat hair brush sets that are easily displayed! Stacking the brushes saves shelf space, yet all brushes can be seen!

NUMBER	DESCRIPTION
915990	Set of 3 Slant (Includes 1", 2", 3")
915790	Set of 3 Flat (Includes 1", 2", 3")

# FOAM BRUSHES & ROLLERS

## Foam Brayers and Rollers

Foam brayers can be used for multiple jobs. Shorter handled brayers are perfect for children's projects. The longer handled roller is great for covering large areas, wetting watercolor paper, print-making and blending colors!

### A. 3" Foam Brayer

~~NUMBER 699063~~

NUMBER 699063-12 (Pack of 12)

### B. 3" Foam Roller

NUMBER 710175 (TOTAL LENGTH 11-1/2")

### C. 6" Soft Foam Brayer

NUMBER 699066

See page 203 for rubber brayers.

### D. Plastic Handle/Foam

Affordable enough to be disposable, these plastic handled brushes are great for applications of water based paints.

NUMBER	DESCRIPTION
710150-10	1" (pack of 10)
710151-10	2" (pack of 10)
710153-10	3" (pack of 10)
710154-10	4" (pack of 10)

### E. Wood Handle/Foam

Can be used with all paints, stains, varnishes, dyes, ceramic glazes, textile paints and watercolor.

NUMBER	DESCRIPTION
710161-10	1" (pack of 10)
710162-10	2" (pack of 10)
710163-10	3" (pack of 10)
710164-10	4" (pack of 10)

### F. ~~Sponge Brush Set of 48~~

~~This set of wood handle sponge brushes contains 12 each of the 1", 2", 3" and 4" sizes.~~

~~NUMBER 710174~~

### G. Foam Daubers Set of 40

Includes a variety of size dots for the entire class. The wood handle is easy for small hands to grip. Fun for all ages and economically priced. Package contains 10 sets of 4 daubers (one of each size).

Sizes: 1/2", 3/4", 1", and 1-1/2".

NUMBER 710146

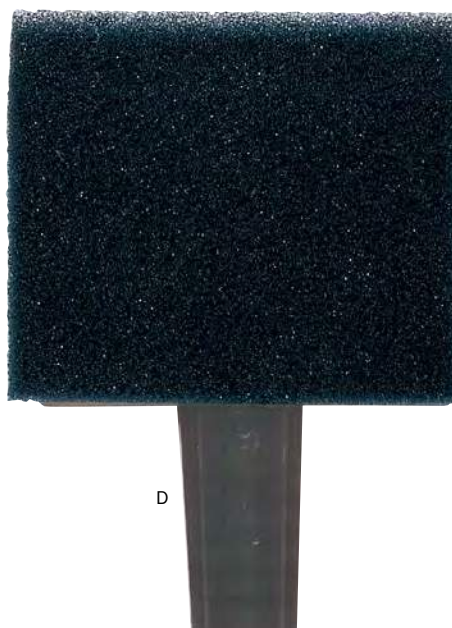

# ~~STUDENT QUALITY WATER MEDIA BRUSHES~~

BRUSHES

48

www.richesonart.com

1.800.233.2404



## ~~Stubby Brushes~~

Easy-to-grip brushes perfect for preschoolers, young children, and the physically challenged. Made of pure hog bristle and mounted in a beautiful colored handle. The handle is designed with a blunt round end to reduce the risk of accidents. Available in 12 different colors that match spill-proof Neatness Jars, found on page 165. Brushes are 7/16" diameter at ferrule.

## ~~Wooden Handle Brushes~~

NUMBER	COLOR	NUMBER	COLOR
402040	Red	402047	Orange
402041	Green	402048	Turquoise
402042	Blue	402049	Violet
402043	Yellow	402050	Brown
402044	White	402051	Pink
402045	Black	402052	Peach

## ~~Wooden Handle Stubby Brush Sets~~

NUMBER	DESCRIPTION
402054	12-brush set (polybagged)
402055	5-brush set (polybagged)
402056	36-brush set (canister)
402057	10-brush set (polybagged)



Canisters filled with these brushes are great for classroom use or for counter top displays!



# SCHOOL BRUSH SETS



A

## School Brush Sets

A. **NUMBER 945400** - An assortment of 42 slightly imperfect assorted hair brushes. These are cosmetic blemishes that will not effect brush performance. Sets will vary.

~~NUMBER 999801 - A set of 36 camel hair easel brushes. Contains 9 each of sizes 4, 5, 6 and 8.~~



B

**NUMBER 999803** - A set of 24 white bristle brushes. Contains sizes 1-12 of rounds and flats. Short handle.

~~B. NUMBER 999700 - A class-pack set of 36 sabeline watercolor brushes. Short handle.~~

**NUMBER 999715** - A class-pack set of 36 oil/acrylic brushes. Assorted flats and rounds.



C

~~NUMBER 999720 - A class-pack set of 36 watercolor brushes. Short handle. Assorted flats, spotters and wash brushes.~~

## Hog Bristle Brush Sets

~~Sets of 6 hog bristle long-handle brushes from the 9579 (flat) and the 9582 (round) series. Polybagged.~~

~~C. NUMBER 945008 - Set includes: flats: 2, 4, 8, 12; rounds: 2, 10.~~



D

## D. Budget Brush Assortment

Contains a dozen each of five different sizes of round, short handle camel hair brushes. Perfect for students. Sizes 2, 3, 4, 5 and 6.

**NUMBER 999992**



E

## E. Utility Brush Set of 48

Beautiful short handle economy white bristle brushes in three desirable widths. Contains:  
24- 515010 1" white bristle  
12- 515020 2" white bristle  
12- 515030 3" white bristle

**NUMBER 515090**

## F. School Quality Cylinder

Brushes are packed in their own display and can be dispensed by the teacher or be used as a self-service display in the store. These are very inexpensive camel hair brushes with simple ferrules and brightly colored plastic handles. There are 24 brushes of each size 1 through 6 making a total of 144 brushes. This is by far the most economical way to purchase student brushes.

**NUMBER 999900**



F

## G. Painter's Brush Kit

This is the ideal starter set for a young painter. The kit has a selection of four student bristle brushes and a steel painting knife. It is packed in a blister pack and is ideal for hanging.

**NUMBER 993000**



G

# BRUSH ASSORTMENTS & RACKS

Jack Richeson believes in supporting artists by utilizing their beautiful works of art to create displays that will entice your artists to browse the wide array of brushes you offer. Our modular displays measure 9" deep, 15-1/2" wide, and 17-3/4" tall (26" with header). **All assortments on pages 48-50 include a free rack if requested with order.**



See page 51 for single unit dimensions.

~~Finest Sable Watercolor Assortment~~

~~Brushes on page 16, 21.  
NUMBER 995039~~  
The assortment includes:

~~Rounds 6228~~

SIZES	QUANTITY
3/0	6
2/0	6
0	6
1	6
2	6
3	6
4	12
5	12
6	12
8	3
10	3
12	2
14	2

~~Flats 6229~~

SIZES	QUANTITY
1/2"	6
3/4"	6
1"	3
1-1/2"	3

~~Flats 9100~~

SIZES	QUANTITY
1/4"	6
1/2"	6
3/4"	6
1"	6

**The 9000 Watercolor Assortment**

Brushes on page 22.  
**NUMBER 995041**  
The assortment includes:

**Rounds 9000**

SIZES	QUANTITY
4/0	6
3/0	6
2/0	6
0	6
1	6
2	6
3	6
4	6
5	3
6	3
8	6
10	6
12	4
24	1

**Flats 9010**

SIZES	QUANTITY
1/8"	6
3/16"	6
1/4"	6
1/2"	6
3/4"	6
1"	6
1-1/2"	1
2"	1
3"	1
4"	1

**8000 Watercolor Brush Assortment**

Brushes on page 21, 23.  
**NUMBER 995038**  
The assortment includes:

**Rounds 8000**

SIZES	QUANTITY
3/0	12
2/0	12
0	12
1	12
2	12
3	12
4	6
5	6
6	12
8	12
10	6
12	6

**Flats 8010**

SIZES	QUANTITY
1/4"	6
1/2"	6
3/4"	6
1"	6

**Flats 9100**

SIZES	QUANTITY
1/4"	12
1/2"	12
3/4"	12
1"	12

**7000 Watercolor Assortment**

Brushes on page 21.  
**NUMBER 995040**  
The assortment includes:

**Rounds 7000**

SIZES	QUANTITY
3/0	6
2/0	6
0	12
1	6
2	12
3	6
4	6
5	6
6	6
8	6
10	6
12	4
24	2

**Flats 7010**

SIZES	QUANTITY
1/8"	6
3/16"	6
1/4"	6
1/2"	6
3/4"	4
1"	4
1-1/2"	2
2"	2

# BRUSH ASSORTMENTS & RACKS

## "Signature" Bristle Assortment

Brushes found on pages 28-29.

NUMBER 995036

The assortment includes:

### Filberts 9626

SIZES	QUANTITY
6	6
8	6
10	6
12	3

### Brights 9627

SIZES	QUANTITY
2	6
6	6
8	6
10	6

### Rounds 9617

SIZES	QUANTITY
6	6
8	6
10	6
12	3

### Flats 9628

SIZES	QUANTITY
2	6
6	6
8	6
10	6

### Fans 9640

SIZES	QUANTITY
2	3
4	3
6	3
8	3

### Egberts 9629

SIZES	QUANTITY
6	3
8	3
10	3
12	3

## ~~Chelveston Bristle Assortment~~

~~Brushes found on pages 30-31.~~

~~NUMBER 995035~~

~~The assortment includes:~~

### ~~Filberts 9026~~

SIZES	QUANTITY
6	6
8	6
10	3
12	3

### ~~Brights 9027~~

SIZES	QUANTITY
6	6
8	6
10	3
12	3

### ~~Rounds 9017~~

SIZES	QUANTITY
6	6
8	6
10	3
12	3

### ~~Flats 9028~~

SIZES	QUANTITY
6	3
8	3
10	3
12	3

### ~~Fans 9240~~

SIZES	QUANTITY
2	3
4	3
6	3
8	3

### ~~Egberts 9029~~

SIZES	QUANTITY
2	3
4	3
6	3
8	3

## Synthetic Oil & Acrylic Assortment

Brushes found on pages 40 and 42.

NUMBER 995034

The assortment includes:

### Brights 9166

SIZES	QUANTITY
6	4
8	4
10	4
12	4

### Rounds 9167

SIZES	QUANTITY
2	4
4	4
6	4
8	4

### Rounds 9118

SIZES	QUANTITY
6	4
8	4
10	4
12	4
16	4
20	4

### Filberts 9165

SIZES	QUANTITY
10	4
12	4
16	4
20	4

### Brights 9164

SIZES	QUANTITY
10	4
12	4
16	4
20	4

## Sash Brush Assortment

Brushes on page 35.

NUMBER 995033

The assortment includes:

### Domes 9049

SIZES	QUANTITY
2/0	12
2	12
3	12
4	12
5	12
6	12

### Pointed 9149

SIZES	QUANTITY
2/0	12
2	12
3	12
4	12
5	12
6	12

**Empty Brush Display Rack** Labels and signage must be custom ordered.

NUMBER 886046

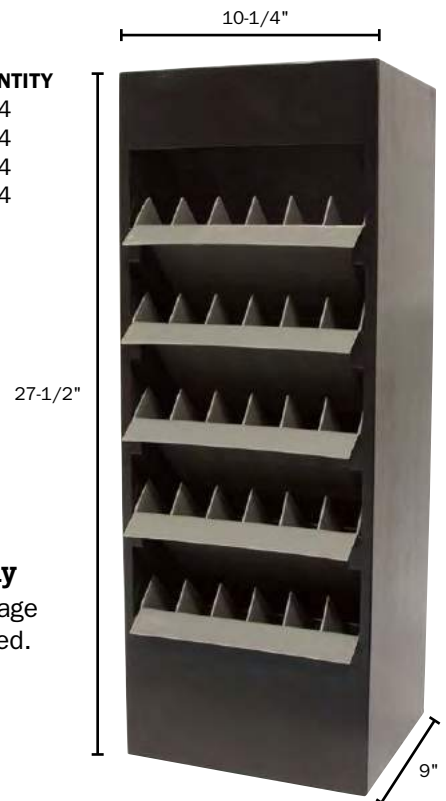

# BRUSH ASSORTMENTS & RACKS

## 7500 Synthetic Oil/ Acrylic Assortment

Brushes on page 41.

NUMBER 995050

The assortment includes:

### Rounds 7500

SIZES	QUANTITY
2	6
3	6
4	6
5	6
6	6
8	6
10	6
12	6

### Flats 7530

SIZES	QUANTITY
2	6
3	6
4	6
5	6
6	6
8	6
10	6
12	6

### Filberts 7550

SIZES	QUANTITY
1	6
2	6
3	6
4	6
6	6
8	6
10	6
12	6

## ~~Pure Sable Oil Assortment~~

~~Brushes on pages 29, 38.~~

~~NUMBER 995043~~

~~The assortment includes:~~

### ~~Brights 9160~~

SIZES	QUANTITY
<del>1</del>	<del>6</del>
<del>2</del>	<del>6</del>
<del>3</del>	<del>6</del>
<del>4</del>	<del>6</del>
<del>6</del>	<del>6</del>
<del>8</del>	<del>4</del>
<del>10</del>	<del>3</del>
<del>12</del>	<del>3</del>

### ~~Rounds 9117~~

SIZES	QUANTITY
<del>2</del>	<del>6</del>
<del>3</del>	<del>6</del>
<del>4</del>	<del>6</del>
<del>6</del>	<del>6</del>
<del>8</del>	<del>6</del>
<del>10</del>	<del>6</del>
<del>12</del>	<del>3</del>
<del>14</del>	<del>3</del>

### ~~Filberts 9161~~

SIZES	QUANTITY
<del>4</del>	<del>6</del>
<del>6</del>	<del>6</del>
<del>8</del>	<del>3</del>
<del>10</del>	<del>3</del>

### ~~Fans 9640~~

SIZES	QUANTITY
<del>2</del>	<del>4</del>
<del>6</del>	<del>4</del>

## ~~Kolinsky Oil Assortment~~

~~Brushes on page 37.~~

~~NUMBER 995044~~

~~The assortment includes:~~

### ~~Rounds 7162~~

SIZES	QUANTITY
<del>2</del>	<del>3</del>
<del>4</del>	<del>3</del>
<del>6</del>	<del>3</del>
<del>8</del>	<del>3</del>
<del>10</del>	<del>3</del>
<del>12</del>	<del>3</del>
<del>16</del>	<del>3</del>
<del>20</del>	<del>3</del>

### ~~Brights 7161~~

SIZES	QUANTITY
<del>2</del>	<del>3</del>
<del>4</del>	<del>3</del>
<del>6</del>	<del>3</del>
<del>8</del>	<del>3</del>
<del>10</del>	<del>3</del>
<del>12</del>	<del>3</del>
<del>16</del>	<del>3</del>

### ~~Filberts 7160~~

SIZES	QUANTITY
<del>2</del>	<del>3</del>
<del>4</del>	<del>3</del>
<del>6</del>	<del>3</del>
<del>8</del>	<del>3</del>
<del>10</del>	<del>3</del>
<del>12</del>	<del>3</del>
<del>16</del>	<del>3</del>
<del>20</del>	<del>3</del>

## ~~Extreme Kolinsky Assortment~~

~~Brushes on page 15.~~

~~NUMBER 995077~~

~~The assortment includes:~~

### ~~Rounds 7777~~

SIZES	QUANTITY
<del>2/0</del>	<del>6</del>
<del>0</del>	<del>6</del>
<del>1</del>	<del>6</del>
<del>2</del>	<del>6</del>
<del>3</del>	<del>6</del>
<del>4</del>	<del>6</del>
<del>5</del>	<del>6</del>
<del>6</del>	<del>6</del>
<del>8</del>	<del>2</del>
<del>10</del>	<del>2</del>
<del>12</del>	<del>2</del>
<del>14</del>	<del>2</del>

### ~~Flats 7778~~

SIZES	QUANTITY
<del>1/4"</del>	<del>4</del>
<del>1/2"</del>	<del>4</del>
<del>3/4"</del>	<del>4</del>
<del>1"</del>	<del>4</del>

## Chinese Bristle Brush Assortment

Brushes on page 32.

NUMBER 995032

The assortment includes:

### Flats 9579 and Rounds 9582

SIZES	QUANTITY
1	36
2	36
3	36
4	24
5	24
6	24
7	24
8	24
9	24
10	24
11	18
12	18

*Purchase a brush rack assortment and receive 250  
FREE brush bags! Bags must be requested when  
placing orders. Please list as a No Charge item  
on your order when purchasing a display.*

## Brush Bags

An age old retail problem is packaging brushes for safe travel from the store to the studio. These great bags are designed to let your customers know the brush they purchased is special and valuable. An essential in every retail shop! Available in packs of 50.

NUMBER 699866 2-1/2" x 11"

NUMBER 699897 2-1/2" x 15"

**Purchase a brush rack assortment and receive 250 FREE brush bags to promote the brushes!** Bags must be requested when placing orders.

Please list as a No Charge item on your order when purchasing a display.



# PAINTING & PALETTE KNIVES



*Professional quality stainless steel spatulas! Made by artists, for artists.*

## Is it a Palette Knife or a Painting Knife?

A palette knife is designed for mixing and works best for that purpose, although many artists will use it for painting. There are many qualities of palette knives.

Palette knives will vary in quality, spring and length. We make three qualities and a variety of sizes. Each responds in a different way.

After extended use in water, steel knives may begin to rust. The stainless steel knives work beautifully and will

not rust. We also carry a complete line of large, tempered steel spatulas for large work or applying gesso.

Finally, we manufacture an inexpensive plastic knife for the beginner. This comes in the traditional flat and also the offset. The offset is easier to work with as it helps to keep ones knuckles out of the paint.

Ample time and thought should go into the selection of a palette knife to ensure getting the correct tool for the project at hand.

## Stainless Steel Spatulas

A selection of the finest Italian Steel Spatulas. Painters of frescos and large landscapes are always looking for high quality knives. These are the best. Print makers mixing ink or painters will find this an excellent selection. All knives have beautiful hand shaped, polished wood handles. Made by artists for artists.

NUMBER	DESCRIPTION	BLADE LENGTH	BLADE WIDTH
A. 800895	Trowel Blade	6-7/8"	1-1/4"
<del>B. 800869</del>	<del>Palette Knife</del>	<del>7-1/2"</del>	<del>1"</del>
C. 800891	Straight Blade	4-3/8"	3/4"
D. 800892	Straight Blade	4-1/8"	1-1/4"
E. 800893	Straight Blade	5-5/8"	1"
F. 800894	Straight Blade	5-3/8"	

# STEEL PAINTING & PALETTE KNIVES

## Richeson Italian Painting Knives

### One Piece Tempered Steel

For painting in the impasto technique or mixing and scraping paint, these steel, trowel-style blades are great. These knives have been hand forged by the same family in Italy for over 100 years. Each knife is mounted to a hand polished rosewood handle. The size and shape of the blade result in great differences in spring and control. Always “dry” test the knife before purchasing.



KNIVES

54

Tempered steel!



www.richesonart.com

1.800.233.2404

NUMBER	DESCRIPTION	BLADE LENGTH	WIDTH	NUMBER	DESCRIPTION	BLADE LENGTH	WIDTH
A. 500804	Offset Painting	1-1/4"	3/8"	G. 500816	Offset Painting	2-3/8"	5/8"
B. 500806	Offset Painting	2-3/8"	1/2"	H. 500818	Offset Painting	2-7/8"	5/8"
C. 500808	Offset Painting	1-5/8"	3/8"	I. 500820	Offset Painting	2-1/2"	1/2"
D. 500810	Offset Painting	1-7/8"	5/8"	J. 500822	Offset Painting	3-1/4"	1/2"
E. 500812	Offset Painting	1-1/8"	3/8"	K. 500824	Offset Painting	1-5/8"	1/2"
F. 500814	Offset Painting	2-1/4"	5/8"	L. 500826	Offset Painting	3-3/8"	1-1/8"

# PAINTING & PALETTE KNIVES



M N O P Q R

	NUMBER	DESCRIPTION	BLADE LENGTH	WIDTH
M.	500828	Offset Painting	2-1/8"	3/4"
N.	500830	Offset Painting	3-1/8"	3/4"
O.	500832	Offset Painting	2-3/8"	1-1/8"
P.	500834	Offset Painting	3-7/8"	1-3/8"
Q.	500836	Offset Painting	2-1/8"	3/4"
R.	500838	Offset Painting	3-1/4"	7/8"



S T U V W X

	NUMBER	DESCRIPTION	BLADE LENGTH	WIDTH
S.	500840	Offset Painting	2-7/8"	3/4"
T.	500844	Offset Painting	2"	3/4"
U.	500846	Offset Painting	4-1/8"	1-1/4"
V.	500848	Offset Painting	2"	1-1/8"
W.	500851	Flat Palette	3-1/2"	5/8"
X.	500852	Flat Palette	3-7/8"	3/4"



Y Z AA BB CC DD

	NUMBER	DESCRIPTION	BLADE LENGTH	WIDTH
Y.	500853	Flat Palette	5-1/4"	5/8"
Z.	500861	Flat Palette	4-5/8"	5/8"
AA.	500862	Flat Palette	3-5/8"	1/2"
BB.	500863	Flat Palette	5-1/4"	5/8"
CC.	500864	Offset Palette	2-3/4"	1/2"
DD.	500865	Offset Palette	3-3/8"	5/8"



EE FF GG HH II JJ

	NUMBER	DESCRIPTION	BLADE LENGTH	WIDTH
EE.	500866	Offset Palette	4-1/4"	5/8"
FF.	500867	Offset Palette	4-3/4"	5/8"
GG.	500870	Flat Palette	3-3/8"	5/8"
HH.	500872	Offset Palette	3-1/8"	3/4"
II.	500880	Flat Palette	3-1/8"	1/2"
JJ.	500881	Multi Angled	3-7/8"	1-1/2"

# PAINING & PALETTE KNIVES

Professional Quality  
Stainless Steel!



## Stainless Steel Painting & Palette Knives

These hand-forged knives have a polished olive wood handle. Great for acrylics because it absolutely will not rust. The size and shape of the blade will result in great differences in spring and control.

NUMBER	DESCRIPTION	LNTH	WDTH
A. 501808	Trowel Knife	1-1/2"	3/8"
B. 501812	Trowel Knife	1-1/8"	3/8"
C. 501814	Trowel Knife	2-1/8"	5/8"
D. 501820	Trowel Knife	2-1/2"	1/2"
E. 501822	Trowel Knife	3-1/4"	1/2"
F. 501862	Flat Palette	5-1/8"	3/4"
G. 501865	Offset Palette	3-1/2"	3/4"
H. 501840	Trowel Knife	2-7/8"	3/4"
I. 501828	Trowel Knife	2-1/4"	3/4"
J. 501881	Multi-angled	3-7/8"	1-1/2"

## Economy Painting Knives

This is a one-piece stamped painting knife that is available in 10 shapes.

NUMBER	DESCRIPTION	LNTH	WDTH
K. 500891	Offset	1-1/4"	3/8"
L. 500892	Offset	1-1/2"	3/8"
M. 500893	Offset	1-7/8"	1/2"
N. 500894	Offset	2-1/4"	5/8"
O. 500895	Offset	2-1/8"	5/8"
P. 500896	Offset	2-3/8"	1/2"
Q. 500897	Offset	2-7/8"	5/8"
R. 500898	Offset	2-3/4"	7/8"
S. 500899	Offset	2-7/8"	3/4"
T. 500900	Offset	3-3/8"	1-1/8"

High Quality  
Student Grade

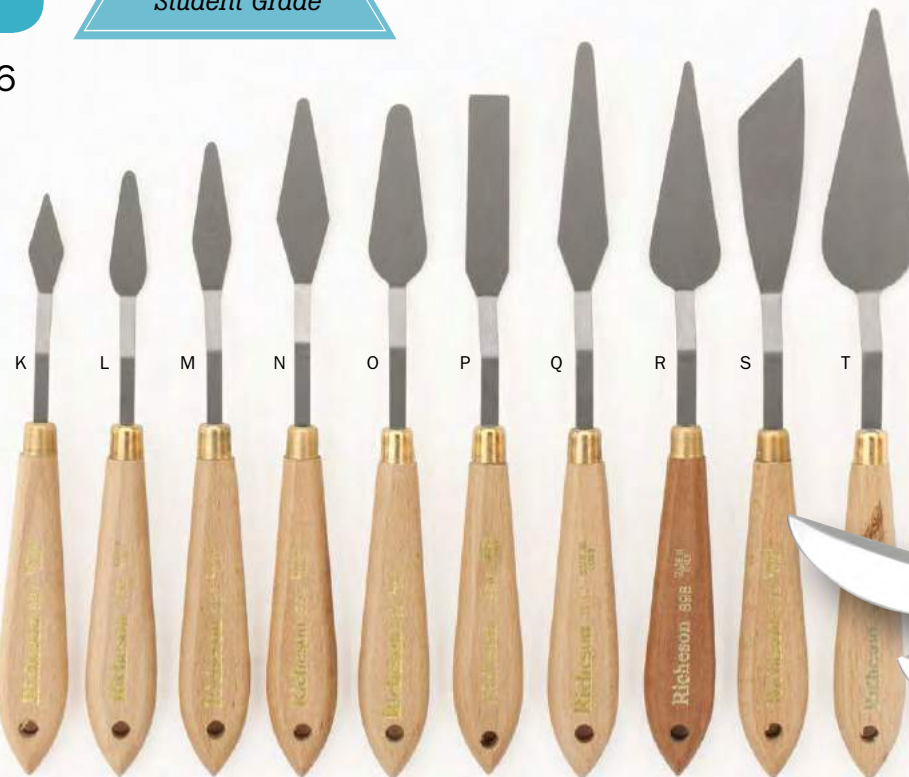

## Stainless Steel Canvas Scraping Knives

These quality steel canvas scrapers effectively remove paint from painted or primed canvas surfaces without damaging it. These scrapers feature double-edged steel blades which are set in polished wooden handles.

NUMBER	BLADE LENGTH
U. 502000	2-5/8"
V. 502005	4-3/8"

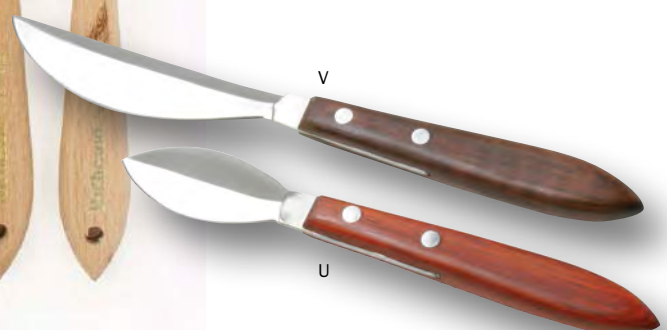



# PAINTING & PALETTE KNIVES

## Plastic Painting and Palette Knives

Safer to use than metal knives, these one-piece molded plastic knives are also more economical, durable and easy to clean. Available in 5 different blade shapes.

### NUMBER DESCRIPTION

- A. 500821 2-3/8" Offset Trowel
- B. 500825 2" Diamond Knife
- C. 500850 3-3/4" Straight Knife
- D. 500868 3" Offset Trowel
- E. 500889 Scotty Painting Knife

## Polybagged Plastic Knives

All plastic knives are available bagged without a header. They are great for workshops!

### NUMBER DESCRIPTION

- ~~500817~~ Includes 1 of each B, D, E
- 500819 Includes 1 of each A - E

## Plastic Knife Canisters

Some styles of our plastic knives can be ordered in clear plastic canisters. Great for counter top display or classrooms.

### NUMBER DESCRIPTION

- 500831 60 of 500850
- 500829 60 of 500868
- 500827 20 each of 821, 825, 850
- 500800 60 of 500889



## Professional Knife Assortment

An assortment of 6 each of 19 different styles of Richeson painting and palette knives. Assortment contains: 500804, 500806, 500808, 500810, 500812, 500814, 500816, 500818, 500820, 500822, 500824, 500826, 500828, 500830, 500832, 500852-53, and 500864-66.

**NUMBER 500875**

## Student Knife Assortment

An assortment of 12 each of 5 plastic knives, and 6 each of 10 styles of student knives. This assortment contains: all five plastic knives and 500891-900.

**NUMBER 500876**

## Supreme Knife Assortment

An assortment of 10 stainless steel knives with olive wood handles and 10 traditional Richeson knives. Assortment contains: 501808-881 and 500851-867.

**NUMBER 500877**

## Empty Knife Display

**NUMBER 993028 (INCLUDES 20 HOOKS)**

## Italian Knife Set

Set of 6 forged steel painting knives in a wooden gift box.

**NUMBER 500883**



- *Traditional Old World pigments*
- *Professional quality, economically priced*
- *Handpainted labels*
- *Brilliant, rich colors*
- *Buttery, reliable consistency*
- *High permanency, free from fading, darkening, yellowing and cracking*
- *Available in 70 colors in 1.25oz and 5oz sizes*



## **Richeson Professional Oils** The Shiva Series

Richeson Premium Oil Colors offer rich color intensity, brilliance of hue and chemical purity for the most discerning artist. Each pure Richeson pigment is ground to its own correct degree of fineness and then formulated individually under exacting laboratory controls. They are guaranteed to be permanent, free from darkening, yellowing, fading and cracking.

During manufacturing, great care must be taken to avoid overworking the pigment. The amount of time required for the milling process varies greatly for each color – anywhere from six hours to three days. The amount of oil required for each pigment is different because each pigment absorbs a varying amount of oil.

*Professionally formulated to satisfy the most discerning master painter!*

## Ingredients

We use only pure, artist-grade, dry pigments. "Non Yellowing Colors" are made with the finest grade of alkali-refined linseed oil available. This type of oil is well-noted for excellent color stability. "Straw" in color, it has a minimal effect on pigment colorization and will not darken with age.

Certain colors such as the whites, flesh colors, ice blue, and brilliant yellow light use safflower oil. With these sensitive pigments that yellow easily, safflower oil produces a much better non-yellowing color.

Where appropriate, we use a blend of linseed and safflower oil, producing the best possible finished product.

## The Making of the Oils

Too much oil can lead to excessive yellowing of the paint, while too little results in paint that is too stiff and lacks sufficient binder to form a durable paint film. The manufacturing process differs for each color, ensuring perfect consistency every time the paint is used.

They are first mixed in a "pony mixer" which has four revolving blades. This process ensures an even distribution of the pigment and helps prevent overheating in this first stage. Next, to further "disperse" or mix the pigment into the oil, the paint is put on a three-roll mill. As the name indicates, this machine has three large steel rollers placed horizontally side by side.

As the paint passes between the rollers, the particles of pigment are broken up, which results in a buttery, even consistency. At this point, all of the air trapped in the dry pigment has been forced out and the particles of pigment are encapsulated by the oil.

## We Age Our Oils

The aging period ensures maximum absorption of the oil into the pigment, creating the richest, creamiest oil paint available. After each batch of oil paint has been allowed to age, we then begin the tubing process.

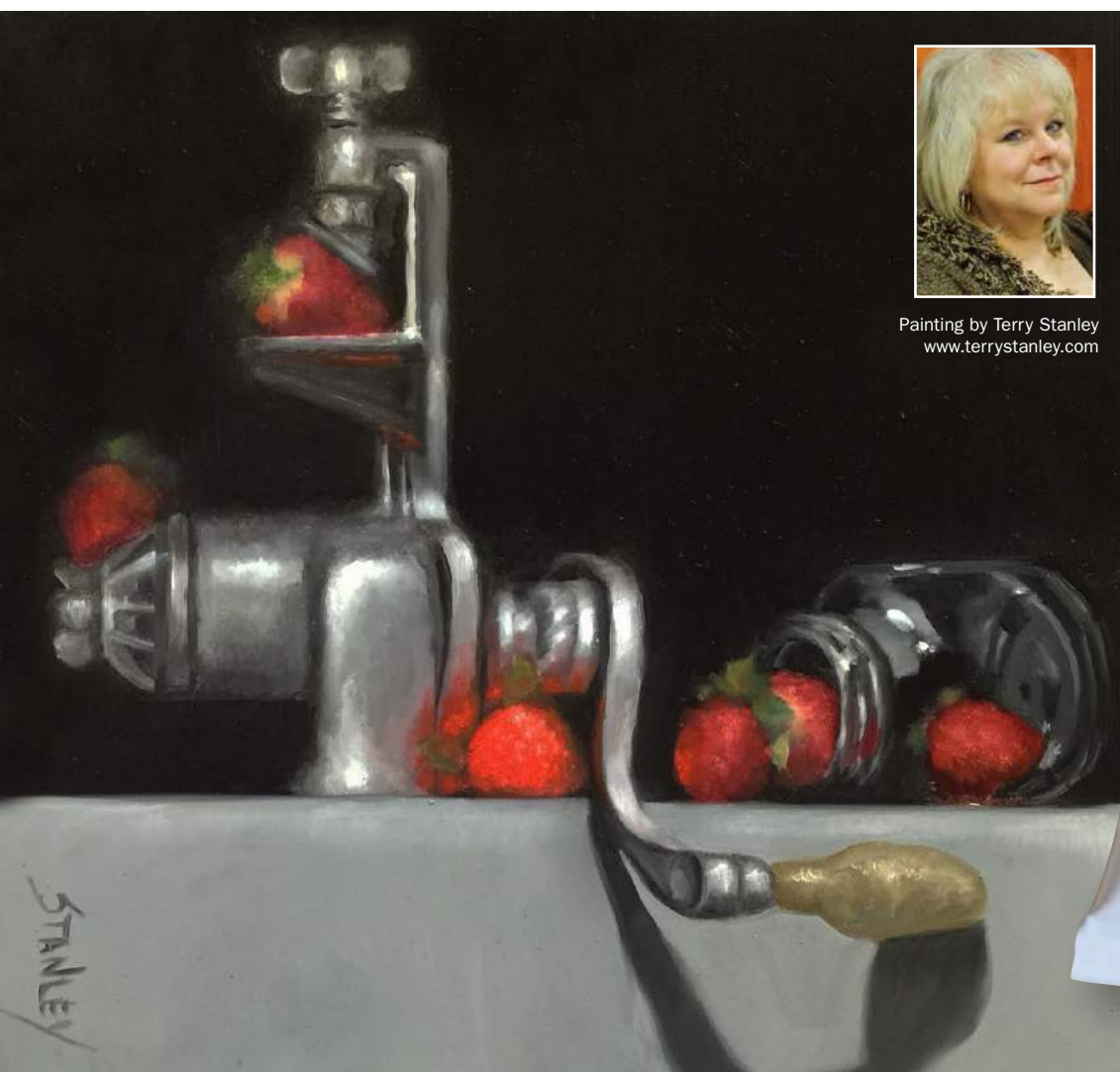

Painting by Terry Stanley  
[www.terrystanley.com](http://www.terrystanley.com)



PAINT

59

[www.richesonart.com](http://www.richesonart.com)

1.800.233.2404

# RICHESON OILS DISPLAYS



PAINT

60

www.richesonart.com

1.800.233.2404

**A. 70 Color 1.25oz Assortment**  
Includes 6 – 1.25oz. (37ml) tubes of each color, 6 – 5oz. (150ml) tubes of titanium white and 6 – 3.75oz. (110ml) jars of these mediums: venice turpentine, linseed oil, rectified turpentine, and Signa-turp. (For display dimensions, see image F above.)  
**NUMBER 120070**

**B. 70 Color 1.25oz Assortment Half Rack**  
Includes 3 – 1.25oz. (37ml) tubes of each color. (For display dimensions, see empty oak displays below, item 120069.)  
**NUMBER 120071 (NOT PICTURED)**

**C. 39 Color 1.25oz Assortment**  
Includes 3 – 1.25oz. (37ml) tubes of 39 of the most popular colors, 6 – 1.25oz. (37ml) tubes of titanium and zinc white and 6 – 5oz. (150ml) tubes of titanium white. Rack comes with 3 of each medium. (For display dimensions, see empty oak displays below, item 120539.)  
**NUMBER 120077 (NOT PICTURED)**

**D. 36 Color 1.25oz Assortment Narrow Rack**  
This oak rack contains 6 each of 36 colors, plus duplicates of the most popular colors. Call for contents. (For display dimensions, see image D above.)  
**NUMBER 120085**

**E. New Color and Partial 5oz. Update Assortment**  
This assortment updates those dealers with the original 59-color rack. It accomodates the 10 new colors in 1.25oz (37ml) tubes as well as 30 of the best-selling colors in 5oz. (150ml) tubes. (For display dimensions, see image F above.)  
**NUMBER 120093**

**F. 50 Color 5oz Assortment**  
This oak rack contains 6 – 5oz. (150ml) tubes of 50 of the most popular colors. Call for rack contents. (Display dimensions shown above.)  
**NUMBER 125096**

## Empty Oak Displays

**NUMBER 120539 (NOT PICTURED)**  
Used for 120077 and 120085.  
44"(h) x 15-3/4"(w) x 7-3/8"(d).  
Header: 15-1/4" x 8".  
**NUMBER 120069 (NOT PICTURED)**  
Used for 120070 and 120071.  
44"(h) x 24-5/8"(w) x 7-3/8"(d).  
Header: 24-1/2" x 9".

**NUMBER 120075 (NOT PICTURED)**  
Used for 120093.  
44"(h) x 24-5/8"(w) x 7-3/8"(d).  
Header: 24-1/2" x 9".  
**NUMBER 125095 (NOT PICTURED)**  
Used for 125096.  
44"(h) x 24-5/8"(w) x 7-3/8"(d).  
Header: 24-1/2" x 9".

## Empty Paint Tubes

Sold in packs of 144.  
**NUMBER DESCRIPTION**  
120534 1.25oz. (37ml) tube  
120535 5oz. (150ml) tube

# RICHESON OILS SETS

*The most affordable professional oils on the market!*

## A. Basic Signature® Oil Set of 6

Includes 1.25oz. (37ml) tubes of: titanium white, ivory black, naphthol red medium, hansa yellow light, ultramarine blue deep, and phthalo green blue shade.

**NUMBER 120068**

## B. Master Signature® Oil Set of 6

Includes 1.25oz. (37ml) tubes of: titanium white, prussian blue, yellow ochre, sap green, burnt umber, and rose madder.

**NUMBER 120999**

## C. Wooden Box Set of 6

Contains the same 1.25oz (37ml) colors as set A above. Packaged in an elegant, slide-top wooden box.

**NUMBER 120079**

## D. Wooden Box Set of 12

This set of 12 contains 1.25oz (37ml) tubes which are presented in a wooden slide-top box. Colors included: titanium white, ivory black, rose madder, naphthol red medium, yellow ochre, Shiva orange, hansa yellow light, phthalo blue deep, ultramarine blue light, phthalo green blue shade, burnt sienna, and burnt umber.

**NUMBER 120080**



PAINT

61

www.richesonart.com

1.800.233.2404



### A Note on Safety Labeling

Richeson Oil paints are tested in accordance to: ASTM D-4236 and bear safety labels to the standards issued by ACMI. While many Richeson Oil colors are AP Approved non-toxic, certain colors do bear the CL label with safety warnings.

# RICHESON OILS — Available in 70 colors in 1.25oz and 5oz.



**120000 / 120059**  
**LF1 - S1 - 0**  
**TITANIUM WHITE**  
 PW6 TITANIUM DIOXIDE  
 PW41 ZINC OXIDE

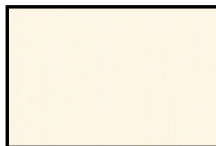

**120001 / 120060**  
**LF1 - S1 - 0**  
**ZINC WHITE**  
 PW4 ZINC OXIDE

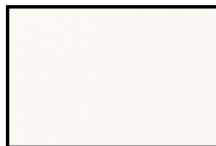

**120002 / 120063**  
**LF1 - S1 - 0**  
**ULTRA WHITE**  
 PW6 TITANIUM DIOXIDE  
 PW4 ZINC OXIDE

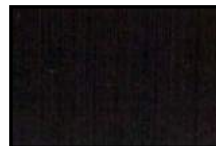

**120003 / 125003**  
**LF1 - S1 - S0**  
**IVORY BLACK**  
 PBK9 BONE BLACK

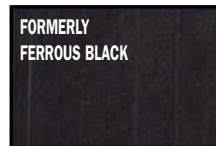

**120004 / 125004**  
**LF1 - S1 - 0**  
**MARS BLACK**  
 PBK11 SYNTHETIC IRON OXIDE

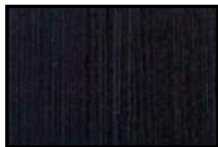

**120005 / 125005**  
**LF1 - S2 - ST**  
**PAYNE'S GRAY**  
 PBK9 BONE BLACK  
 PBK7 CARBON BLACK  
 PB29 SOD ALUM SULPH



**120006 / 125006**  
**LF1 - S1 - S0**  
**LIGHT RED**  
 PR102 NATURAL IRON OXIDE  
 PR101 SYNTH IRON OXIDE



**120007 / 125007**  
**LF3 - S3 - S0**  
**ALIZARIN CRIMSON**  
 PR83 1,2-DIHYDROXY-  
 ANTHRAQUININE LAKE



**120008 / 125008**  
**LF1 - S1 - S0**  
**VENETIAN RED**  
 PR102 NAT IRON OXIDE  
 PR101 SYNTH IRON OX



**120009 / 125009**  
**LF1 - S5 - T**  
**QUINACRIDONE ROSE**  
 PR122 QUIN RED  
 PV19 QUINACRIDONE



**120010 / 125010**  
**LF1 - S4 - 0**  
**CADMIUM RED DEEP**  
 PR108:1 CAD SELENO-SULFIDE  
 COPRECIPATED W/BARIUM  
 SULFATE



**120011 / 125011**  
**LF3 - S3 - ST**  
**ROSE MADDER**  
 PR83  
 1,2-DIHYDROXYANTHRAQUININE  
 LAKE / PY3 ARYLIDE YLW 10G



**120012 / 125012**  
**LF1 - S4 - 0**  
**CADMIUM RED SCARLET**  
 PR108:1 CAD SELENO-SULFIDE  
 COPRECIPATED WITH BARIUM  
 SULFATE



**120013 / 125013**  
**LF1 - S4 - 0**  
**CADMIUM RED PALE**  
 PR108:1 AND P020:1CAD  
 SELENO-SULFIDE COPRECIPATED  
 W/BARM SULFATE

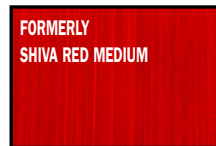

**120014 / 125014**  
**LF2 - S2 - S0**  
**NAPHTHOL RED MEDIUM**  
 PR170 NAPHTHOL CARBAMIDE



**120015 / 125015**  
**LF3 - S2 - T**  
**SHIVA RED CRIMSON**  
 PR83  
 1,2-DIHYDROXYANTHRAQUININE  
 LAKE / PV19 QUINACRIDONE



**120016 / 125016**  
**LF1 - S2 - 0**  
**FLESH TINT**  
 PW6 TITANIUM DIOXIDE  
 PY42 SYNTHETIC IRON OXIDE



**120017 / 125017**  
**LF1 - S1 - ST**  
**YELLOW OCHRE**  
 PY42 SYNTH IRON OXIDE  
 PY43 NATURAL IRON OXIDE



**120018 / 125018**  
**LF1 - S1 - 0**  
**CADMIUM YELLOW LIGHT**  
 PR35:1 CADMIUM SELENO-  
 SULFIDE COPRECIPATED WITH  
 BARIUM SULFATE



**120019 / 125019**  
**LF1 - S1 - 0**  
**CAD YELLOW MEDIUM**  
 PY35:1 CAD SELENO-SULFIDE  
 COPRECIPATED W/BAR SULFATE  
 PY65 ARYLIDE YELLOW RN



**120020 / 125020**  
**LF1 - S2 - S0**  
**NAPLES YELLOW**  
 PY74 ARYLIDE YLW TITAN  
 PW6 DIOXIDE  
 PY42 SYNTH IRON OXIDE



**120021 / 125021**  
**LF1 - S3 - S0**  
**INDIAN YELLOW**  
 PY83 DIARYLIDE YELLOW HR70



**120022 / 125022**  
**LF1 - S1 - S0 UNBLEACHED**  
**TITAN**, PW6 TITAN DIOXIDE  
 PY42 SYNTH IRON OXIDE  
 PBR7 NAT IRON OX  
 PY3 ARYLIDE YLW 10G

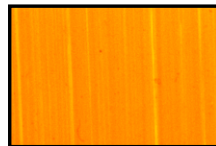

**120023 / 125023**  
**LF1 - S4 - 0**  
**CADMIUM ORANGE**  
 P020:1 CADMIUM  
 SELENO-SULFIDE COPRECIPATED  
 W/BAR SULFATE

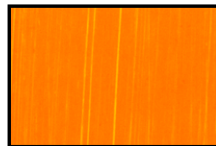

**120024 / 125024**  
**LF3 - S2 - S0**  
**SHIVA ORANGE**  
 P016 DIARYLIDE ORANGE  
 PY65 ARYLIDE YLW RN

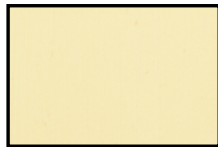

**120025 / 125025**  
**LF1 - S2 - S0**  
**BRILLIANT YELLOW LIGHT**  
 PW6 TITANIUM DIOXIDE  
 PY3 ARYLIDE YLW 10G



**120026 / 125026**  
**LF2 - S2 - 0**  
**SHIVA YELLOW CITRON**  
 PG17 CHROMIUM OXIDE  
 PW6 TITANIUM DIOXIDE  
 PY3 ARYLIDE YLW 10G



**120027 / 125027**  
**LF2 - S2 - S0**  
**HANSA YELLOW**  
 PW6 TITANIUM DIOXIDE  
 PY1 ARYLIDE YELLOW G



**120028 / 125028**  
**LF2 - S2 - S0**  
**HANSA YELLOW MEDIUM**  
 PY65 ARYLIDE YELLOW RN  
 PY3 ARYLIDE YELLOW 10G



**120029 / 125029**  
**LF2 - S2 - S0**  
**HANSA YELLOW PALE**  
 PY3 ARYLIDE YELLOW 10G  
 PW6 TITANIUM DIOXIDE



**120030 / 125030**  
**LF1 - S2 - S0**  
**TURQUOISE**  
 PG7 CHLORINATED COPPER  
 PB15 PHTHALOCYANINE COPPER  
 PW6 PHTHAL TITAN DIOXIDE



**120031 / 125031**  
**LF1 - S6 - S0**  
**CERULEAN BLUE**  
 PB36 OXIDES OF COBALT  
 AND ALUMINIUM

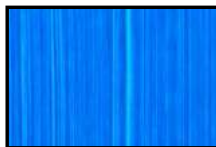

**120032 / 125032**  
**LF1 - S5 - T**  
**COBALT BLUE**  
 PB28 OXIDES OF COBALT  
 AND ALUMINIUM

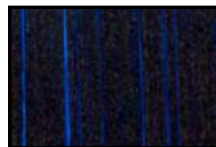

**120033 / 125033**  
**LF1 - S2 - T**  
**PRUSSIAN BLUE**  
 PB27 FERRIC AMMONIUM  
 FERROCYANIDE

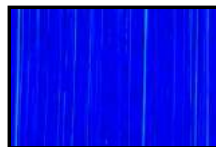

**120034 / 125034**  
**LF1 - S2 - T**  
**ULTRAMARINE BLUE DEEP**  
 PB29 SODIUM ALUMINO  
 SULPHOSILICATE

**LIGHTFASTNESS: (LF)** Excellent=1 Very Good=2 Fair=3 **SERIES: (S)** 1, 2, 3, 4, 5, 6  
**OPACITY:** Opaque = O Transparent = T Semi-Opaque = SO Semi-Transparent = ST

**Richeson Oils 16oz** 120065 16oz Titan. Zinc White  
 120066 16oz Titanium White  
 120067 16oz Zinc White

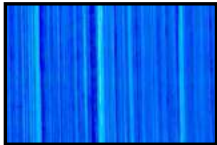

120035 / 125035  
 LF1 - S2 - T  
**ULTRAMARINE BLUE LIGHT**  
 PB29 SODIUM ALUMINO  
 SULPHOSILICATE



120036 / 125036  
 LF1 - S2 - ST **ICE BLUE**  
 PW6 TITANIUM DIOXIDE  
 PB27 FERRIC AMMONIUM  
 FERROCYANIDE  
 PBR7 NATURAL IRON OXIDE



120037 / 125037  
 LF1 - S2 - T  
**PHHALO BLUE DEEP**  
 PB15 COPPER PHTHALOCYANINE



120038 / 125038  
 LF1 - S2 - T  
**PHHALO BLUE LIGHT**  
 PB15:4 COPPER PHTHALOCYANINE



120039 / 125039  
 LF1 - S6 - ST  
**COBALT VIOLET LIGHT**  
 PV49 COBALT AMMONIUM  
 PHOSPHATE



120040 / 125040  
 LF1 - S3 - SO  
**MANGANESE VIOLET**  
 PV16 MANGANESE AMMONIUM  
 PHOSPHATE



120041 / 125041  
 LF1 - S2 - ST  
**DIOXAZINE VIOLET**  
 PV23 DIOXAZINE  
 PB29 SODIUM ALUMINO  
 SULPHOSILICATE



120042 / 125042  
 LF1 - S2 - SO  
**OLIVE GREEN**  
 PG17 CHROMIUM OXIDE  
 PBK9 BONE BLACK  
 PY65 ARYLIDE YELLOW RN



120043 / 125043  
 LF1 - S2 - ST  
**SAP GREEN**  
 PG7 CHLORINATED COPPER  
 PY74 PHTHALOCYANINE ARYLIDE YLW  
 PBK7 CARBON BLACK



120044 / 125044  
 LF1 - S4 - T  
**VIROIDIAN**  
 PG18 HYDRATED CHROMIUM OXIDE



120045 / 125045  
 LF1 - S2 - O  
**TERRA VERTE**  
 PG17 CHROM OXIDE / PW6 TITAN  
 DIOXIDE / PBK11 SYNTH IRON OX /  
 PB29 SOD ALUM SULPHO



120046 / 125046  
 LF1 - S2 - SO  
**LEAF GREEN**  
 PY65 ARYLIDE YELLOW RN  
 PBK11 SYNTHETIC IRON OXIDE



120047 / 125047  
 LF1 - S4 - SO  
**CADMIUM GREEN**  
 PY35:1 AND PG7 CAD  
 SELENO-SULFIDE COPRE-  
 CIPATED W/BARIUM SULFATE



120048 / 125048  
 LF1 - S2 - T  
**PHHALO GREEN - BLUE SH**  
 PG7 CHLORINATED COPPER  
 PHTHALOCYANINE



120049 / 125049  
 LF1 - S3 - O  
**CHROME OXIDE  
 GREEN DEEP**  
 PG17 CHROMIUM OXIDE



120050 / 125050  
 LF1 - S3 - O  
**CHROME OXIDE  
 GREEN LIGHT**  
 PG17 CHROMIUM OXIDE  
 PW6 TITANIUM DIOXIDE



120051 / 125051  
 LF1 - S1 - O  
**BURNT SIENNA**  
 PR102 NATURAL IRON OXIDE



120052 / 125052  
 LF1 - S1 - O  
**BURNT UMBER**  
 PBR7 NATURAL IRON OXIDE



120081 / 125081  
 LF1 - S1 - O  
**BURNT UMBER COOL**  
 PBR7 NATURAL IRON OXIDE



120053 / 125053  
 LF1 - S1 - ST  
**RAW SIENNA**  
 PY43 NATURAL IRON OXIDE



120054  
 LF1 - S1 - O  
**RAW UMBER**  
 PBR7 NATURAL IRON OXIDE



120082 / 125082  
 LF1 - S1 - O  
**RAW UMBER COOL**  
 PBR7 NATURAL IRON OXIDE  
 PBK26 MANGANESE FERRITE BLACK

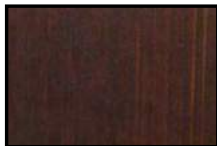

120055 / 125055  
 LF1 - S3 - SO  
**ASPHALTUM**  
 PR101 SYNTH IRON OX  
 PBK9 BONE BLACK  
 PY74 ARYLIDE YELLOW



120056 / 125056  
 LF1 - S1 - SO  
**VAN DYKE BROWN**  
 PR102 NATURAL IRON OXIDE  
 PBR7 NATURAL IRON OXIDE

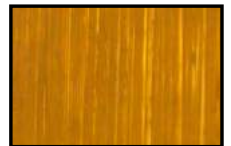

120057 / 125057  
 LF1 - S1 - O  
**GOLDEN OCHRE**  
 PY42 SYNTHETIC IRON OXIDE



120058 / 125058  
 LF1 - S2 - O  
**GREEN GOLD**  
 PG17 CHROMIUM OXIDE  
 PY65 ARYLIDE YELLOW RN



120083 / 125083  
 LF1 - S4 - T  
**PERMANENT ALIZARIN**  
 PR177 ANTHRAQUINOID RED

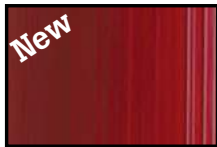

120084 / 125084  
 LF1 - S3 - T  
**QUINACRIDONE RED**  
 PV19 QUINACRIDONE

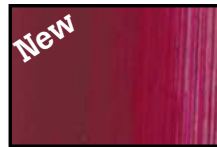

120086 / 125086  
 LF1 - S2 - T  
**QUINACRIDONE MAGENTA**  
 PR122 QUIN RED



120087 / 125087  
 LF1 - S3 - T  
**QUINACRIDONE VIOLET**  
 PV19 QUINACRIDONE



120088 / 125088  
 LF1 - S2 - ST  
**NAPHTHOL RED LIGHT**  
 PR112 NAPHTHOL RED AS-D



120089 / 125089  
 LF1 - S2 - T  
**ULTRAMARINE VIOLET**  
 PV15 SODIUM ALUMINO  
 SULPHOSILICATE



120090 / 125090  
 LF1 - S2 - T  
**PHHALO GREEN - YLWSDH**  
 PG36 COPPER PHTHALOCYANINE  
 COMPLEX



120091 / 125091  
 LF1 - S3 - T  
**TRANSP. RED OXIDE**  
 PR101 SYNTH IRON OX



120092 / 125092  
 LF1 - S3 - ST  
**TRANSP. YELLOW OXIDE**  
 PY42 SYNTHETIC IRON OXIDE

# SHIVA® PAINTSTIK® ARTIST COLORS

*Professional Fine Art! Underpainting! Fabric Arts! Craft Projects!*



When you're ready to start your next oil painting, pick up Shiva Paintstik Artist Colors instead of a brush. Ideal for sketching and outlining, Shiva Paintstik Artist Colors are refined linseed oil blended with a quality pigment and solidified into a convenient stick form.

Paintstiks can be spread or blended and used in conjunction with conventional oil paint. There are no unpleasant odors or fumes, so you can paint virtually anywhere, at any time, on almost any surface from paper to panel to fabric.

Paintstiks are "self-sealing." That means they form a protective film

so the color won't rub off or dry out. They always stay moist and fresh, providing an indefinite shelf life because they reseal in 24 hours. This film is easily removed by peeling it away with a paper towel, or rubbing it off gently. It can also be removed by carefully paring it with a knife (it can also be sharpened to a point in this manner).

When the stick has begun to wear to the edge of the sleeve, simply loosen the sleeve from the oil stick at the seam, open the sleeve and push the stick forward. Press the sleeve around the oil stick again and repeat the peeling process as needed.

Remember that Shiva Paintstik Artist Colors are oil color, the same as tube oils, so all the same techniques, mediums and surfaces can be used including varnishes. Paintstiks are available in 55 Professional Colors, 22 Iridescent and 12 Student Colors.

Shiva Paintstik Artist Colors are tested in accordance to: ASTM D-4236 and bear safety labels to the standards issued by ACMI. While many Paintstik Colors are AP Approved non-toxic, certain colors do bear the CL label with safety warnings.



## Why Shiva Paintstik Artist colors?

- No offensive odor
- Hypo-allergenic
- No solvents!
- Easy clean up: Soap, water, baby wipes
- A colorless blender with no pigment is available
- Rich, creamy, buttery consistency
- Colors are fully mixable
- Most colors dry within 24 hours
- Compatible with other oil paints & mediums

## Great for the following:

- Canvas
- Fabric
- Wood
- Metal
- Glass
- Glazing
- Stenciling
- Stamping
- Drawing
- Painting
- Walls
- Plastics
- Ceramics
- Faux Finish



# SHIVA® PAINTSTIK® ARTIST COLORS

## 52 Color Assortment

Two racks (#121252) that include 6 each of 52 carded colors, 6 each of the Basic, Traditional and Iridescent Primary sets of 6.

**NUMBER 121254**

## 36 Color Assortment

1 rack (#121252) that includes 6 each of 36 carded colors, 6 each of the Basic, Traditional and Iridescent Primary sets of 6.

**NUMBER 121253**

## Empty Display Rack

Rack dimensions are 37"(h) x 23-7/8"(w) x 4-1/2"(d). The header is 9" tall and 24-1/2" long.

**NUMBER 121252**

## Half Class Pack Mini Paintstiks

Made for school use. Includes 1 each of sets 121600, 121601, 121602, 121603, 121604, 121605, 121606, 121608, and 121614.

**NUMBER 121900**

## Class Pack Mini Paintstiks

Made for school use. Includes 2 each of sets 121600, 121601, 121602, 121603, 121604, 121605, 121606, 121608, and 121614.

**NUMBER 121901**

*Easy cleanup –  
No solvents needed!*

4-1/4"  
deep

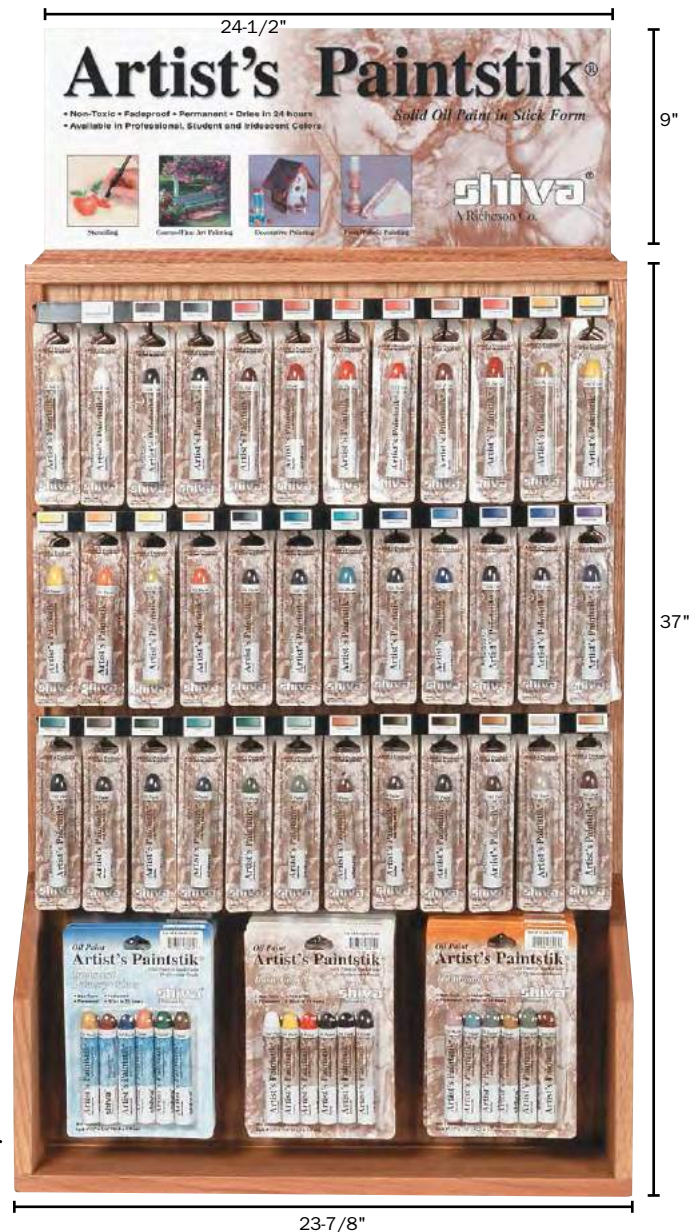

PAINT

65

*Paintstiks are a  
beautiful medium for  
fine art paintings!*



Painting by Diana Lyn Côté  
[www.dianalyncote.com](http://www.dianalyncote.com)

[www.richesonart.com](http://www.richesonart.com)

1.800.233.2404

# SHIVA® PAINTSTIK® ARTIST COLOR SETS

student

Student Paintstik® Sets are an excellent cost-effective option for schools. Student Paintstiks contain a lower pigment content than the Professional version. Student Paintstiks are only available in sets.

## 12 Student Colors

- NUMBER 121501**
- Student White
  - Student Yellow
  - Student Orange
  - Student Red
  - Student Deep Red
  - Student Green
  - Student Blue
  - Student Purple
  - Student Ochre
  - Student Red Brown
  - Student Black
  - Student Brown

## 6 Student Colors

- NUMBER 121500**
- Student Green
  - Student Blue
  - Student Brown
  - Student White
  - Student Yellow
  - Student Red



professional

## 12 Professional Colors

- NUMBER 121502**
- 121201 Titanium White
  - 121203 Ivory Black
  - 121208 Alizarin Crimson
  - 121222 Azo Orange
  - 121211 Naphthol Red
  - 121219 Azo Yellow
  - 121226 Phthlo Blue
  - 121238 Phthlo Green
  - 121229 Ultramarine Blue
  - 121245 Burnt Sienna
  - 121247 Raw Umber
  - 121216 Yellow Ochre

## 12 Iridescent Colors

- NUMBER 121508**
- 121716 Iridescent White
  - 121723 Iridescent Orange
  - 121720 Iridescent Red
  - 121721 Iridescent Pink
  - 121725 Iridescent Turquoise
  - 121724 Iridescent Blue
  - 121727 Iridescent Green
  - 121726 Iridescent Purple
  - 121718 Iridescent Charcoal
  - 121730 Iridescent Copper
  - 121722 Iridescent Gold
  - 121719 Iridescent Silver

## 6 Iridescent Fashion

- NUMBER 121301**
- 121716 Iridescent White
  - 121721 Iridescent Pink
  - 121725 Iridescent Turquoise
  - 121726 Iridescent Purple
  - 121728 Iridescent Leaf Green
  - 121718 Iridescent Charcoal

## 6 Iridescent Tropical Colors

- NUMBER 121307**
- 121710 Iridescent Lime
  - 121711 Iridescent Grape
  - 121712 Iridescent Watermelon
  - 121713 Iridescent Jade
  - 121714 Iridescent Sapphire
  - 121715 Iridescent Magenta



PAINT

## 6 Basic Colors

- NUMBER 121302**
- 121201 Titanium White
  - 121219 Azo Yellow
  - 121211 Naphthol Red
  - 121240 Sap Green
  - 121229 Ultramarine Blue
  - 121203 Ivory Black

## 6 Iridescent Primary

- NUMBER 121300**
- 121720 Iridescent Red
  - 121723 Iridescent Orange
  - 121722 Iridescent Gold
  - 121727 Iridescent Green
  - 121724 Iridescent Blue
  - 121729 Iridescent Brown

## 6 Traditional Colors

- NUMBER 121303**
- 121213 Dusty Rose
  - 121231 Wedgewood Blue
  - 121205 Pewter Gray
  - 121216 Yellow Ochre
  - 121243 Celadon Green
  - 121212 Barn Red

## 3 Mini Popular

- NUMBER 121604**
- 121214 Medium Pink
  - 121233 Diox Purple
  - 121224 Teal Blue

## 3 Mini Spring

- NUMBER 121609**
- 121725 Iridescent Turq
  - 121721 Iridescent Pink
  - 121728 Iridescent Leaf Grn

## 3 Mini Iridescent Jewel

- NUMBER 121614**
- 121713 Iridescent Jade
  - 121714 Iridescent Sapphire
  - 121715 Iridescent Magenta

## 3 Mini Primary

- NUMBER 121600**
- 121211 Naphthol Red
  - 121229 Ultramarine Blue
  - 121219 Azo Yellow

## 3 Mini Summer

- NUMBER 121610**
- 121727 Iridescent Green
  - 121724 Iridescent Dark Blue
  - 121726 Iridescent Purple

## 3 Mini Gold Silver Copper

- NUMBER 121608**
- 121722 Iridescent Gold
  - 121719 Iridescent Silver
  - 121730 Iridescent Copper

## 6 Colonial Colors

- NUMBER 121304**
- 121223 Navy Blue
  - 121248 Chocolate
  - 121234 Mauve
  - 121244 Meadow Green
  - 121230 Slate Blue
  - 121249 Beige

## 3 Mini Earthtone

- NUMBER 121605**
- 121250 Asphaltum
  - 121244 Meadow Green
  - 121240 Sap Green

## 3 Mini Autumn

- NUMBER 121611**
- 121720 Iridescent Red
  - 121723 Iridescent Orange
  - 121731 Iridescent Lt Gold

## 3 Mini Winter

- NUMBER 121612**
- 121716 Iridescent White
  - 121718 Iridescent Charcoal
  - 121729 Iridescent Brown

## 3 Mini Classic

- NUMBER 121602**
- 121240 Sap Green
  - 121208 Alizarin Crimson
  - 121228 Prussian Blue

## 3 Mini Toning

- NUMBER 121603**
- 121201 Titanium White
  - 121203 Ivory Black
  - 121246 Burnt Umber

## 3 Mini Sorbet

- NUMBER 121616**
- 121710 Iridescent Lime
  - 121711 Iridescent Grape
  - 121712 Iridescent Watermelon

## 16 Mini Matte Assortment

- NUMBER 121306**
- 121201 Ttm White
  - 121203 Ivory Black
  - 121245 Burnt Sienna
  - 121246 Burnt Umber
  - 121208 Aliz Crimson
  - 121211 Napthol Red
  - 121222 Azo Orange
  - 121219 Azo Yellow
  - 121216 Yellow Ochre
  - 121243 Celadon Green
  - 121251 Sap Green
  - 121231 Wdgdw Blue
  - 121228 Prussian Blue
  - 121234 Mauve
  - 121233 Diox Violet
  - 121200 Matte Colorless Blndr (Full Stick)

## 16 Mini Iridescent Assortment

- NUMBER 121305**
- 121716 Irid White
  - 121724 Irid Dark Blue
  - 121725 Irid Turquoise
  - 121718 Irid Charcoal
  - 121726 Irid Purple
  - 121719 Irid Silver
  - 121727 Irid Green
  - 121720 Irid Red
  - 121728 Irid Leaf Green
  - 121721 Irid Pink
  - 121729 Irid Brown
  - 121722 Irid Gold
  - 121730 Irid Copper
  - 121723 Irid Orange
  - 121731 Irid Light Gold
  - 121717 Colorless Blndr (Full Stick)



# SHIVA® PAINTSTIK® ARTIST COLORS

## Professional Grade Paintstiks – 55 colors available in open stock and sets

							Lightfastness: Excellent I Very Good II Fair III

## Iridescent Professional Grade Paintstiks – 22 colors available in open stock and sets

## Student Grade Paintstiks – 12 colors available in 6- and 12-piece sets only

### Jumbo Paintstiks

2 colors available, plus the Colorless Blender (item 121803).

--	--

# RUBBING PLATES & FABRIC KIT

## Rubbing Plates

Rubbing plates can be used for texture with Paintstiks on fabric or even on ceramic pieces!

- Create your own painted fabrics
- Easy to clean
- Easy flat storage
- Many other styles available
- Works for monoprints with gelatin printing

## Each pack contains: 6 different plates

NUMBER	DESCRIPTION
210900	Op Art
210901	Curves
210902	Leaves
210903	Triangles
210904	Garden Flowers
210905	Floral Fantasy
210907	Doodles
210908	Kaleidoscope

## Paintstik on Fabric Starter Kit

This great starter kit is an easy way to introduce yourself to this fantastic creative process.

Polybagged kit contains: Book, stencil brushes, set of six leaves rubbing plates, and six iridescent paintstiks.

NUMBER 121902



### Op Art

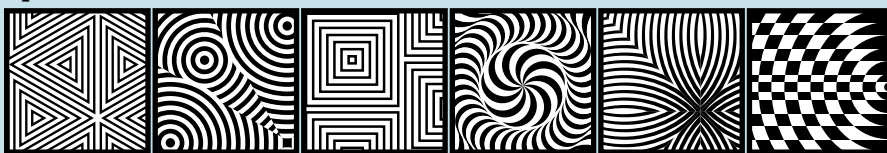

### Curves

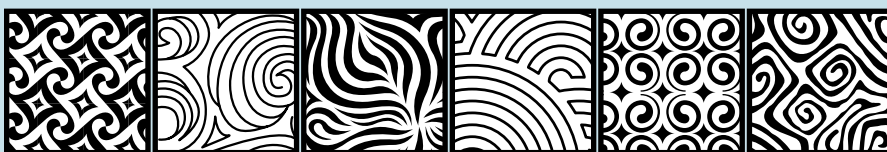

### Leaves



### Triangles

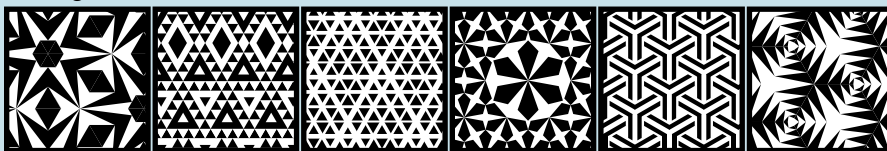

### Garden Flowers



### Floral Fantasy

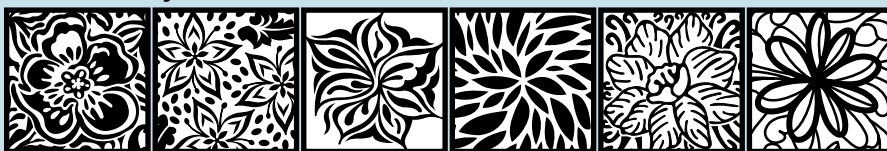

### Doodles



### Kaleidoscope

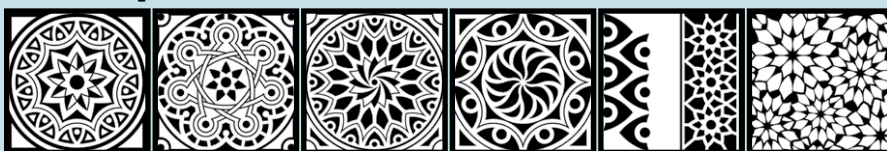

# SHIVA® PAINTSTIK® ARTIST COLORS

## How To Use Shiva Paintstik Artist Colors

**Shiva® Paintstik® Artist Colors** are real paint in solid form. They are not crayons, oil pastels or soft pastels, but highly refined drying oils blended with durable pigments and then solidified into stick form.

**Shiva® Paintstik® Artist Colors** perform beautifully with all conventional oil paints. All of the same techniques that you are accustomed to using in oil painting and more can be successfully performed using Shiva Paintstik Artist Colors.

**Cleans up with  
soap and water –  
NO SOLVENTS  
REQUIRED!**

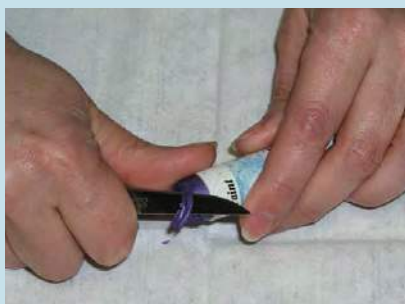

**Self-sealing** - Paintstiks form a protective film, so the color won't rub off or dry out. Protective film is easy to peel off when you are ready to paint. Tip can be easily shaped to meet your specific needs. Outer paper label peels back and oils will push up for maximum use of paint.

### Paintstiks on Fabric Book

Embellish fabric with ease. Beginners and seasoned fiber artists alike can achieve fabulous results with Shiva Paintstik Artist Colors and a few simple tools. Learn everything you need to know about applying paintstik color to fabric, from basic information about paintstiks, to detailed instructions that will enable you to transform ordinary pieces of fabric into unique works of art. This comprehensive guide offers:

- Five techniques for adding paintstik color to fabric, including: rubbing, stenciling and masking applications.
- Easy-to-follow instructions with step-by-step photographs.
- Answers to the most common questions about paintstiks.
- Complete procedures for preparation, heat setting and clean up.
- Dozens of color photographs for inspiration.

**NUMBER LB0003 (32 PAGES)**

### Design Magic Book

Explore the magical world of design and create personal prints in far less time than you ever thought possible. Design Magic is easier than appliqué and faster than fusing! Enjoy the adventure as paintstik artist Shelly Stokes brings out your inner designer with a simple three-step method that takes you from initial design to fabulous fabric with stencils, brushes and Shiva Paintstik Artist Colors.

**NUMBER LB0011 (56 PAGES)**

### Rubbing Plate Roundup Book

If you love texture, this book is for you! Rubbing Plate Roundup by Shelly Stokes is the definitive guide to adding visual and dimensional texture to your fabric and craft projects with the simplest tool imaginable — the molded plastic rubbing plate. Each technique is fully illustrated with complete supply lists, clear instructions and beautiful step-by-step photographs.

**NUMBER LB0012 (64 PAGES)**

Books are soft cover  
and measure 10.7" x 8.4"

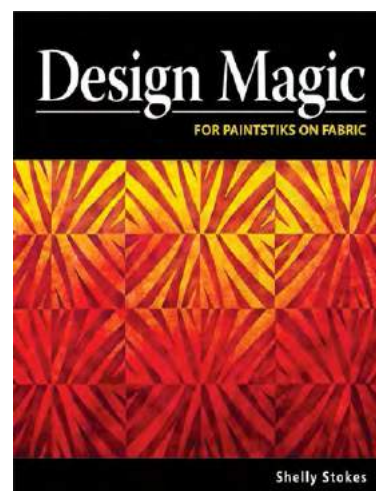
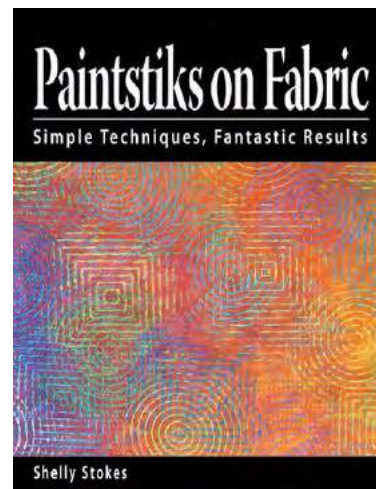



Painting by James Gurney  
www.jamesgurney.com/

PAINT

70

"Casein is a water-based paint medium with working properties that resemble gouache, cel vinyl—and, in some respects, oil. I've used all of those latter paints quite a bit, but casein has qualities all its own. It can be used transparently, but it has great opacity when you need it, something often lacking in acrylic. It's one of the oldest paint mediums, dating all the way back to the Egyptians.

The paint has a delicious, unforgettable aroma that resembles the smell of cosmetics. The milk-based binder seals each layer enough so that they won't pick up with later application. The paint dries to an attractive matte surface that photographs very well, particularly in saturated tints, which is one of the reasons it was so popular with early illustrators.

Casein lends itself to bold, painterly handling and 'finding the image in the paint.' I think it's one of the best paints for oil painters who want to experiment in water media, or who need to find a paint that travels better than oil."

– JAMES GURNEY

## What is Casein?

Casein (kay'seen) is a quick-drying, aqueous medium using a milk-based binding agent, and is one of the most durable mediums known to man. Nine thousand year old casein cave paintings have been discovered in Asia. Later, the medium was used by Byzantine, Roman and Renaissance artists, including the Old Masters.

Known for their versatility and array of capabilities, casein paints can be used to create a variety of effects

from the rich opaques of oil to thin watercolor washes. Because casein has an exceptional integrity of color and always dries to a perfect matte finish, it is unexcelled for art reproduction. The velvety matte finish can also be buffed to a satin sheen or varnished to produce a resemblance to oils. Over time, casein pigments become resistant to moisture and as history has proven, the medium has a durability and permanence which has easily stood the test of time.

Because it dries quickly, it is possible to lay down a glaze and move onto the next stage within a few hours instead of waiting for days, or even months, as with oils.



Richeson Paints are tested in accordance to ASTM D-4236 and bear safety labels to the standards issued by ACMI.

# RICHESON CASEIN ARTIST COLORS The Shiva Series



6-1/2"

25-1/2"

5-1/2"  
DEEP

24-1/4"



7-1/2"

44-1/8"

7-5/8"  
DEEP

15-3/4"



71

## Empty Paint Tubes

Sold in packs of 144.

NUMBER	DESCRIPTION
120534	1.25oz. (37ml) tube
120535	5oz. (150ml) tube



## Filled Richeson Casein Rack

Includes:

- 3 – 1.25oz. (37ml) tubes of all 32 colors
- 3 – 5oz. (150ml) tubes of Titanium White
- 3 – 3.75oz. (110ml) jars of Casein Emulsion

NUMBER 120537

## Empty Richeson Casein Rack

Dimensions are 25-1/2"(h) x 24-1/4"(w) x 5-1/2"(d). Header measures 6-1/2" tall and 23" wide.

NUMBER 120536

## ~~Richeson Casein Narrow Rack~~

~~This oak rack contains 6 each of 32 colors, plus duplicates of the most popular colors for a total of 216 tubes!~~

- ~~• 12 each 1.25oz. (37ml) titanium white and ivory black~~
- ~~• 6 each 1.25oz. (37ml) all other colors~~
- ~~• 2 3.75oz. (110ml) jars of Casein Emulsion~~
- ~~• 6 Basic Colors Sets of 6~~

NUMBER 120538

## ~~Empty Casein/Oil Narrow Rack~~

~~Works with assortment 120538 above and oil assortment 120085 (page 60.)~~

NUMBER 120539

All assortments include a FREE rack if requested with order. Call Customer Service at 1.800.233.2404 for contents of our racks.

# RICHESON CASEIN ARTIST COLORS The Shiva Series



PAINT

72

**A. Basic Casein Set of 6**

Set includes 1.25oz. (37ml) tubes of: titanium white, ivory black, rose red, naples yellow, ultramarine blue deep, and Shiva green (phtalo).

**NUMBER 120533**

**B. Color Theory Set of 6**

Perfect for color theory, casein has little color shift and mixes easily! Set includes 1.25oz. (37ml) tubes of: Shiva rose, cadmium yellow light, ultramarine blue deep, cadmium orange, Shiva green (phtalo), and Shiva violet.

**NUMBER 120550**

**c. Underpainting Set of 6**

Set includes 1.25oz. (37ml) tubes of: burnt sienna, raw umber, payne's grey, yellow ochre, cadmium red pale, and permasol blue.

**NUMBER 120560**

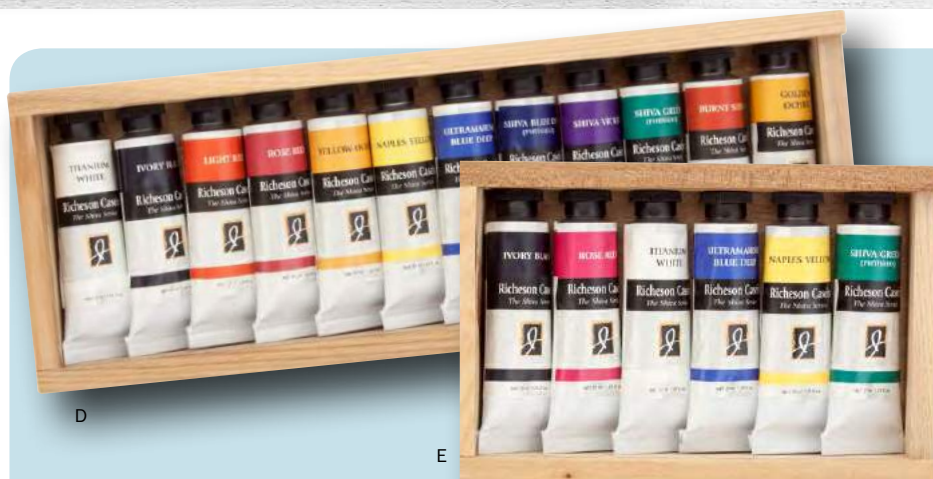

**D. Wooden Box Set of 12**

This set contains 1.25oz (37ml) tubes which are presented in a wooden slide-top box. Includes: titanium white, ivory black, rose red, light red, naples yellow, yellow ochre, Shiva green, ultramarine blue deep, Shiva blue, Shiva violet, burnt sienna and golden ochre.

**NUMBER 120541**

**E. Wooden Box Set of 6**

Set includes 1.25oz. (37ml) tubes of: titanium white, ivory black, rose red, naples yellow, ultramarine blue deep, and Shiva green (phtalo) packaged in an elegant, slide-top wooden box.

**NUMBER 120542**

www.richesonart.com

1.800.233.2404



# RICHESON CASEIN ARTIST COLORS The Shiva Series

## Shiva® Casein Colors – 32 colors available in open stock and sets

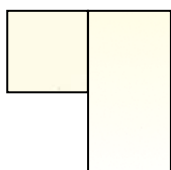

Titanium White  
120500 I

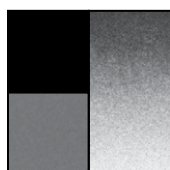

Ivory Black  
120501 I

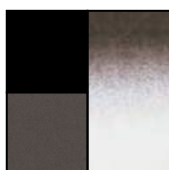

Half-tone Black  
120502 I



Payne's Grey  
120503 I

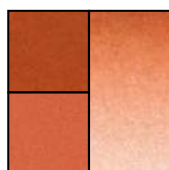

Light Red  
120504 I

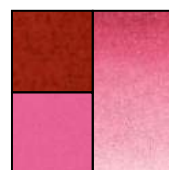

Alizarin Crimson  
120505 III

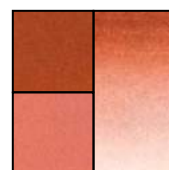

Venetian Red  
120506 I

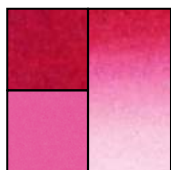

Rose Red  
120507 I

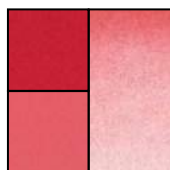

Cadmium Red Deep  
120508 I

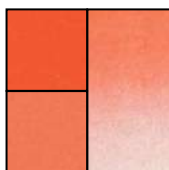

Cadmium Red Pale  
120509 I

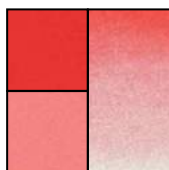

Cadmium Red Scarlet  
120510 I

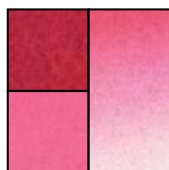

Shiva Rose  
120511 III



Yellow Ochre  
120512 I

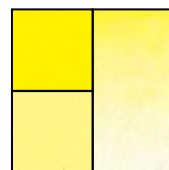

Cadmium Yellow Lt  
120513 I

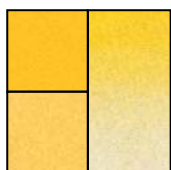

Cadmium Yellow Med  
120514 I

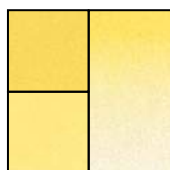

Naples Yellow Hue  
120515 II

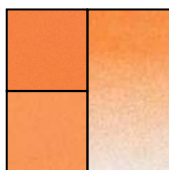

Cadmium Orange  
120516 I



Cerulean Blue  
120517 I

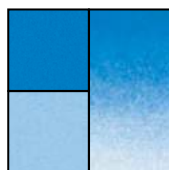

Cobalt Blue  
120518 I



Ultramarine Blue Deep  
120519 I



Shiva Blue (Phthalo)  
120520 I

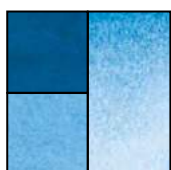

Permasol Blue  
120521 I



Shiva Violet  
120522 II



Terra Verte  
120523 I

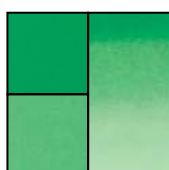

Cadmium Green  
120524 I



Shiva Green (Phthalo)  
120525 I



Chrom. Oxide Green  
120526 I

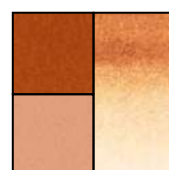

Burnt Sienna  
120527 I

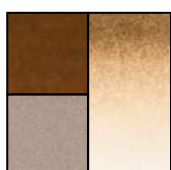

Burnt Umber  
120528 I

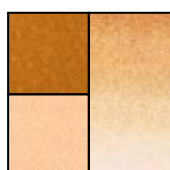

Raw Sienna  
120529 I



Raw Umber  
120530 I

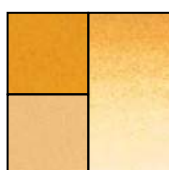

Golden Ochre  
120531 I

### Key:

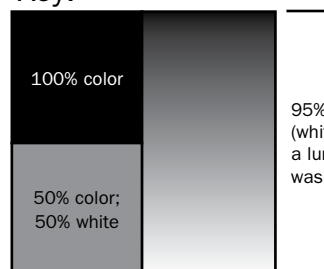

100% color

50% color;  
50% white

95% color; 5% white  
(white helps to achieve  
a luminous watercolor  
wash effect)

### Lightfastness:

Excellent I    Very Good II    Fair III

## Helpful Tips for Caseins

- Choose a rigid, non-oily surface for your work
- Establish correct drawing and value patterns with a thin underpainting
- Dilute caseins with water to make washes & transparent glazes
- Casein colors, especially reds, oranges, and yellows, tend to shift after drying
- Lighten colors by adding more water or brighten them by adding powdered pigment
- To correct an overly dark area, cover it with a more opaque layer of a lighter color
- When working on a gessoed panel, correct any errors with an eraser or a 1:9 ammonia and water mixture

For more tips and information on casein, check out our printed Color Chart.

**NUMBER 100002**



## The basics

### Can I paint on canvas with casein?

Casein can be used on canvas, although only in very thin application. Since Casein in its cured state can be brittle, we recommend that artists paint on rigid surfaces.

If you want the texture of paint on canvas, mounting the canvas on wood or panel is the best solution.

### What about other surfaces?

Just about anything! Casein can be used on interior walls, metal, wood, laminates, metal, glass or ceramics.

Clean the surface thoroughly and on walls, metal, wood or laminates, “prime” the surface with a couple layers of gesso or a PVA glue such as Weldbond (mix 50/50 with water).

For slick surfaces like glass, ceramics or metal, use denatured alcohol to thoroughly clean the surface. You can then prime the surface with a PVA & water solution as above.

### Can I paint on watercolor paper?

Again, rigidity counts! You can paint on 140lb. watercolor paper if the painting will be properly framed shortly after completion. 300 lb. paper is a much better choice because of its stiffness – and properly varnished and cradled could even be framed without glass.

### Are caseins archival?

Yes. Properly done and with a protective varnish, caseins can last longer than oils, especially oils on canvas. They also will not crack or yellow.

### Are casein paints transparent?

The degree of opacity varies from color to color, with white being opaque and affecting the opacity of other colors it’s mixed with.

When you make your color chart, include a section for each color combination to be applied over a strip of a mid-tone gray. By doing this, you create an opacity reference.

### How should I apply caseins?

You have a myriad of choices! You can apply casein “juicy” like watercolors, impasto like oils, or anything in between.



Painting by Robert Sutherland  
<http://fineartamerica.com/profiles/robert-sutherland.html>

A rigid surface, such as a canvas panel, is critical when applying casein thickly (to prevent cracking if the surface is flexed). You can use a painting knife, brushes, cloth or even your fingers to apply casein to your surface.

### What is half-tone black?

The pigment in half-tone black is more finely dispersed than in the other casein colors. Think of it as a separate, transparent color, not “pale black.”

Half-tone black is meant to be applied as a glaze. Use it on your color mixing chart to show the effects of half-tone black over other casein colors. For instance, half-tone black over burnt sienna results in a beautiful purple.

### Why does the color chart show a 95% color + 5% white wash?

Adding a touch of white to your casein colors will help you control your washes. 5% white will make washes lighten gradually from opaque to transparent instead of changing too rapidly. Try it. You won’t believe the difference.

### Can I keep casein from drying on my palette?

Keep a spray bottle of water handy and spritz the paint on your palette periodically. Covering your palette with plastic wrap (after spritzing) and putting it in your fridge overnight will keep it especially fresh. One can avoid the drying issues entirely by only squeezing out approximately as much paint as will be used at one time.

### What kind of brushes work best with casein and what is the best way to clean them?

Casein, like acrylic, can be rough on brushes if you don’t take good care of them! Its heavy consistency can also be an issue. Use bristle brushes or synthetic soft hair, but never use one made from sable!

Keep your used brushes in a brush washer with the heads partially immersed in water until you clean them with water and dish soap. For especially stubborn colors, add a bit of ammonia to the soap before washing. Rinse very well, and be sure to “snap” your brush back to its original shape before setting it out to dry. Brush cleaners and conditioners also work well and are another way to keep your brushes usable for years to come.

### What grounds can I paint on?

Rabbit skin glue, PVA glue and acrylic gesso. Just make sure there is no oil on the grounds.

## The tools

### What should I use for a palette?

Because casein will stain plastic palettes, a butcher tray, porcelain tray or a glass surface backed with a mid-tone gray paper provides an excellent mixing surface. Alternately, a disposable paper palette can be used for its convenience and ease of clean up.

# RICHESON CASEIN ARTIST COLORS

## Do casein colors mix like other paints?

Yes! Wet casein does look about a shade darker than it will when it dries. Get to know the paint by making yourself a color-mixing chart.

## Can I mix casein with other mediums?

Yes you can! Use casein over watercolor or gouache or as an underpainting for acrylic, pastel or oils. If using casein under oils, apply a barrier layer of Damar varnish over the casein before the oil paint. Casein can also be used under oils as an excellent underpainting medium.

## The finishing

### What about varnish?

Varnish is a matter of preference. A gloss varnish intensifies the color, while a matte acrylic varnish will preserve that “authentic casein” look.

Wait until the surface has cured 2-3 weeks and no longer reconstitutes with water and then apply the varnish in the same manner as you would for an acrylic or oil painting.

If you don't have time to wait, you can use a spray varnish (applied in light coats in a well-ventilated area) within a day of the painting being dry to the touch. The casein will continue to cure even when varnished in this manner.

### What about glazes?

There are three methods of glazing caseins to avoid inadvertently lifting a previously painted layer. First, and most obvious, is to wait a couple of weeks until the casein cures.

Second is to wait until the casein is dry to the touch; prepare your glaze by adding a small amount of paint to water or to Casein Emulsion. A little goes a long way – just be aware that Casein Emulsion used “straight” in this manner will dry to a semi-gloss finish, not casein's usual matte surface.

The final method is to use PVA glue such as Weldbond. Mix 1 part Weldbond to 3 parts water. If your painting is small enough, it may be easier to pour the glue solution over the painting and tilt it to cover the entire piece instead of brushing it on.



Painting by Stephen Quiller  
www.stephenquiller.com

## Richeson Casein and Water Media

Internationally known artist, author and workshop instructor **Stephen Quiller** has made his mark exploring the limitless opportunities of mixed media in works that can be described as a contemporary blend of abstract and representational.

“I started out painting in a more traditional way with transparent watercolor,” explains Quiller, “but I found it limited my options. I



Painting by Robert Tanenbaum  
www.rtanenbaum.com

began to explore other water-based paints, and over time, I discovered a combination of media helped me better capture the spiritual essence of the landscapes I was painting.

“I work with a variety of water media because they're compatible, yet have different characteristics that lend themselves to different aspects of a painting. I use casein because I love its velvety matte qualities and I find it's the perfect medium for depicting the low winter light in the mountains around my gallery and home in Colorado.”

## Casein & Color Studies

Although he had used casein in college, **Robert Tanenbaum** didn't begin working with it seriously until the early 1970's when a fellow illustrator recommended its use particularly for highlights. It was much easier to use casein instead of watercolor or gouache.

With some experimentation, Tanenbaum found that casein was also perfect for tight details and textures, and that its quick drying properties made it ideal for preliminary color sketches and for underpainting.

## Casein & Underpainting

Casein is also the perfect medium to use for underpainting. As long as an artist doesn't lay on casein too thickly, it's an excellent choice for underpainting because it's insoluble once it dries.

The casein will easily accept the oil and will form a good mechanical bond. Using acrylic gesso works fine with casein or oil paint because it has an ‘open’ surface to accept the paint layer and form a mechanical bond.



Painting by Douglas Wiltraut  
www.douglaswiltraut.com

## Casein & Egg Tempera

**Doug Wiltraut**, an experienced egg tempera painter, has discovered the beautiful qualities casein has to offer. While egg tempera is characterized by pureness of color and luminosity, it also has some qualities that make it difficult to work with. Richeson Casein paints are able to achieve some of the beautiful qualities of egg tempera without some of its drawbacks.

# STEPHEN QUILLER PROFESSIONAL WATERCOLORS

Made using the traditional stone ground milling process.

PAINT

Painting by Stephen Quiller  
[www.stephenquiller.com](http://www.stephenquiller.com)

76

Many years ago, Jack made the decision to develop and then manufacture a top line of watercolor. It was in 1994 when he first consulted with his late dear friend, Zoltan Szabo. He also consulted Ralph Mayer's indispensable book, Hilary Page's great book and then studied several books by Wilcox. He had long, serious conversations with Stephen Quiller and studied the works of Tom Lynch, Chris Van Winkle, Tom Fong and Milford Zornes.

Over the years, Jack had many discussions with experienced Grumbacher color chemists and many discussions with famous color maker Jacques Blockx. Six times he threw away all that had been done and started over.

After all of that research and planning, we are proud to say that Jack Richeson & Co. has developed the true professional watercolor. The paint is made through the traditional stone ground milling process and provides pure, brilliant color.

## Quiller Watercolor Rack

This beautiful oak rack is available empty or filled. The filled assortment includes 4 each of 41 15 ml tubes.

- Dimensions: 32 1/2"(h) x 25 1/2"(w) x 4 1/4"(d)
- Box dimensions: 37" x 29" x 8"
- Ships by UPS

NUMBER 110210 (filled)  
NUMBER 110252 (empty)



# STEPHEN QUILLER PROFESSIONAL WATERCOLORS

Stephen Quiller Professional Watercolors — 53 colors available in open stock and sets

Titanium-White 110000   Non-staining PW6	Naples-Yellow 110003   Mineral, Non-stain PW4, PY35, PY42	Transparent Yel 110006   Trans, Staining PY154	Bismuth-Yellow 110009   Trans, Staining PY184	Cadmium-Yellow 110012   Mineral, Non-stain PY35	Cad-Yel-Med 110013  * Opaque, Staining PY35	Cad-Yel-Deep 110014   Mineral, Non-stain PY35, PO20	Gamboge 110015  ● Mineral, Staining PY1, PR3	Trans-Mars-Yel 110016  ● Trans, Non-stain PY42
Trans-Mars-Br 110017   Trans, Non-stain PWR101	Cad-Orange 110018   Mineral, Non-stain PO20	Perm-Orange 110020   Staining PO62	Vermilion 110021   Trans, Staining PO73	Cad-Red-Orange 110022   Non-staining PO20	Cad-Red-Med 110024   Mineral, Non-stain PR108	Trans-Mars-Red 110026  ● Trans, Non-stain PR101	Rich-Red-Light 110027   Trans, Staining PR254	Quin-Red 110030  * Trans, Staining PR202
Quin-Rose 110033 Trans, Staining PV19	Rose-Madder-Dp 110036   Trans, Staining PR264	Quin-Magenta 110038  * Trans, Staining PR122	Deep-Magenta 110039   Trans, Non-stain PV19	Mauve 110042   Trans, Staining PV23	Ultra-Violet-Red 110044   Trans, Staining PV15	Ultra-Violet 110045  □ Mineral, Non-stain PV15	Manganese-Violet 110048  □ Mineral, Non-stain PV16	Cobalt-Violet 110051  □ Mineral, Non-stain PV14
Cobalt-Blue 110054  ■ Mineral, Non-stain PB28, PB15:1	Cobalt-Blue-Dp 110055   Mineral, Non-stain PB74	Ultra-Blue 110057  □ Mineral, Non-stain PB29	Cerulean-Blue 110060  □ Mineral, Non-stain PB35	Richeson-Blue 110063   Trans, Staining PB15:3	Prussian-Blue 110064  ▲ Trans, Staining PB27	Indanthrene-Blue 110066   Trans, Staining PB60	Payne's-Grey 110069   Trans, Staining PB11, PB29, PB15:1	Rich-Turquoise 110071   Staining PB15:3, PG7
Turquoise-Green 110072  □ Mineral, Non-stain PB36	Golden-Green 110073  ▲ Trans, Semi-stain PY154, PG36	Emerald-Green 110075  ■ Mineral, Non-stain PG18	Richeson-Green 110078   Trans, Staining PG7	Perm-Green-Lt 110079   Staining PY154, PG7	Cobalt-Green 110080  ▲ Opaque, Staining PG50	Hooker's-Green 110081   Trans, Staining PY42, PG7	Phthalo-Grn-Yel 110084   Trans, Staining PG36	Sap-Green 110087   Trans, Staining PG7, PY154
Yellow-Ochre 110090   Mineral, Non-stain PBr7	Italian-Earth 110091  ■ Trans, Non-stain PBr7	Burnt-Umber 110092  ■ Trans, Non-stain PBr7	Burnt-Sienna 110093   Mineral, Non-stain PBr7	Venetian-Red 110094   Mineral, Non-stain PR102	Sepia 110096   Staining PBr7, PBk11	Neutral-Tint 110099   Trans, Staining PBk11, PB15:1, PV19	Ivory-Black 110100   Mineral, Staining PBk9	

## LIGHTFASTNESS:

Excellent-I    Very-Good-II    Fair-III



Quiller paints are tested in accordance to: ASTM D-4236 and bear safety labels to the standards issued by ACMI. While many colors are AP Approved non-toxic, certain colors do bear the CL label with safety warnings.

## A. Quiller Watercolor Set of 8

This set includes a printed color chart that lists valuable information for the artist such as lightfastness, the complement color and the pigment make-up for each color. Set of 8 contains: Cadmium Yellow-Light, Vermilion, Quinacridone Rose, Ultramarine Violet, Richeson-Blue, Ultramarine Blue, Richeson-Green, and Burnt Sienna.

NUMBER 110200

## Quiller Watercolor Sets

(See symbols in color chart for set contents.)

- NUMBER 110205    Set/6 Sedimentary □
- NUMBER 110215    Set/3 Staining \*
- NUMBER 110220    Set/3 Green/Blue ▲
- NUMBER 110225    Set/3 Granulating ■
- NUMBER 110230    Set/3 Transparent ●



# ST. PETERSBURG WATERCOLORS

A professional quality watercolor made in a country rich with art history. These liquid-poured, semi-moist, full pan watercolors are manufactured in a St. Petersburg factory that has been producing color for over 100 years. The liquid-poured process is thought by professionals to be the highest quality grade watercolors. The finest raw materials and pigments are used to guarantee the highest possible light and colorfastness.

PAINT

78



## St. Petersburg Watercolor Sets of 24

NUMBER	DESCRIPTION
58024	Original Set of 24
58023	Expanded Set of 24
58030	Sequel Set of 24

*\*All sets are full size pans.*

## Wooden Box Watercolor Master's Set of 12

A rectangular slide top box that includes: cadmium lemon, yellow ochre, ultramarine, cobalt blue, scarlet, madder lake, burnt sienna, burnt umber, yellow green, Russian green, emerald green, and black neutral.

NUMBER 994027

## St. Petersburg Watercolor Rack

This oak, slotboard rack contains 6 each of all 55 colors and an attractive header. Rack is included free with assortment **if requested** with order. Pans are full size. Rack measures 18-1/2" x 16" x 31-1/4".

NUMBER 58055



# ST. PETERSBURG WATERCOLORS

## St. Petersburg Watercolors – Pans available in open stock and sets

Zinc White #58155   ▶	Cadmium Lemon #58101    ▲	Lemon #58143    ▶	Hansa Yellow #58133    ●▶	Cadmium Yellow #58102   ▲●	Yellow Ochre #58103   ▲●	Naples Yellow #58144   ▶	Raw Sienna #58104   ▲●
Golden #58105    ●▲	Golden Deep #58140    ▶	Cadmium Orange #58106   ●▲	Orange Lake #58130    ●	Titian's #58151    ▶	Shak. Red #58128   ●	Red Ochre #58107   ▲	Burnt Sienna #58108   ▲
English Red #58109   ●▲	Vermillion Hue #58152    ▶	Cad. Red Light #58137   ▶	Scarlet #58110    ●▲	Ruby #58150    ▶	Carmine #58112    ▲	Madder Lake #58111    ▲	Rose #58129    ●
Quin. Rose #58149    ▶	Claret #58153    ▶	Quin. Lilac #58148    ▶	Violet Rose #58125    ●	Violet #58113    ●▲	Blue Lake #58127    ●▶	Idanthrene Blue #58139	Ultramarine Blue #58114    ●▲
Russian Blue #58116    ▲	Brilliant Blue #58126    ●	Cobalt Blue #58115   ●▲▶	Prussian Azure #58136    ▶	Azure Blue #58135    ▶	Turquoise Blue #58154    ▶	Cerulean Blue #58138   ▶	Green Earth #58131   ●
Yellow Green #58118    ●▲	Green Light #58141    ▶	Green Original #58134    ●	Emerald Green #58117    ▲	Oxide of Chromium #58146   ▶	Russian Green #58119    ●▲	Olive Green #58145   ▶	Mars Brown #58121   ▲
Burnt Umber #58122   ●▲	Raw Umber #58120   ▲	Voron. Black #58132   ●▶	Sepia #58123    ▲	Indigo #58142    ▶	Payne's Gray #58147    ▶	Black Neutral #58124    ●▲	

### Sets of Pan Watercolors

(See symbols in color chart for set contents.)

- 58023 Expanded Set of 24 ●
- 58024 Original Set of 24 ▲
- 58030 Sequel Set of 24 ▶

All individual Yarka™ St. Petersburg Watercolors are packaged according to ACMI regulations. While many colors are AP Approved non-toxic, certain colors bear the CL label with safety warnings.

Lightfastness:  
Excellent I    Very Good II    Fair III



Pans are only available in full size.

# RICHESON MEDIUMS



Richeson Mediums are tested in accordance to: ASTM D-4236 and bear safety labels to the standards issued by ACMI. While some Richeson mediums are AP approved non-toxic, certain mediums bear the CL label with safety warnings.

**Venice Turpentine** is used in mixing your own mediums. Its properties include adhesiveness and an enamel-like gloss.

NUMBER	DESCRIPTION
120703	Venice Turpentine 3.75oz.
120704	Venice Turpentine 8oz.
120705	Venice Turpentine 16oz.

**Stand Oil** is a very heavy bodied oil. It wets pigments well, producing paint with good flowing qualities that levels easily and reduces brush marks.

NUMBER	DESCRIPTION
120707	Stand Oil 3.75oz.
120708	Stand Oil 8oz.
120709	Stand Oil 16oz.

**Copal Painting Medium** improves the flow of paint from the brush and speeds the drying rate for oil colors. Avoid overloading paint film with copal as this can cause excessive yellowing.

NUMBER	DESCRIPTION
120710	Copal Medium 3.75oz.
120711	Copal Medium 8oz.

**Rectified Turpentine** is highly refined and crystal clear. It is used to thin oil paints and for cleaning brushes.

NUMBER	DESCRIPTION
120712	Rectified Turpentine 3.75oz.
120713	Rectified Turpentine 8oz.
120714	Rectified Turpentine 16oz.
120715	Rectified Turpentine 32oz.

**Linseed Oil** is highly purified white linseed oil of the finest quality. It thins the paint, but still acts as a binder for pigments.

NUMBER	DESCRIPTION
120716	Linseed Oil 3.75oz.
120717	Linseed Oil 8oz.
120718	Linseed Oil 16oz.
120719	Linseed Oil 32oz.
120720	Linseed Oil Gallon

**Damar Varnish** is considered to be the best of the natural picture varnishes. It increases the brilliancy of the colors and provides moderately high gloss. Damar Varnish responds readily to ordinary solvents used in painting restoration.

NUMBER	DESCRIPTION
120721	Damar Varnish 3.75oz.
120722	Damar Varnish 8oz.
120723	Damar Varnish 16oz.
120724	Damar Varnish 32oz.

**Signa-Turp** is a colorless turpentine substitute which possesses the properties of turpentine without its strong odor. It is especially ideal for people who are allergic to turpentine or do not like its strong odor.

NUMBER	DESCRIPTION
120725	Signa Turpentine 3.75oz.
120726	Signa Turpentine 8oz.
120727	Signa Turpentine 16oz.
120728	Signa Turpentine 32oz.
120729	Signa Turpentine Gallon

**Casein Emulsion** is the pure casein binder that is used to make casein paints. As such, it can be mixed with casein paints to improve the brushability or flow without altering any other characteristics. When using casein paints for very thin washes, mix one part Casein Emulsion with five parts water to ensure color brilliance and to maintain adhesion and integrity of the paint film.

NUMBER	DESCRIPTION
120730	Casein Emulsion 3.75oz.
120731	Casein Emulsion 16oz.

## Watercolor Mediums

**Liquid Masque** allows the artist to block out areas so that they will not accept color. Simply paint Liquid Masque on the areas where color is not wanted. Paint with watercolors, tempera, acrylics, casein, gouache, or airbrush colors. Remove dry Masque by peeling or rubbing with a soft eraser.

NUMBER	DESCRIPTION
120702	Liquid Masque 3.75oz.

**Liquid Masque Brush Cleaner** is used for cleaning Liquid Masque out of brushes.

NUMBER	DESCRIPTION
120700	Brush Cleaner 3.75oz.



# RICHESON MEDIUMS

## Richeson Acrylic Gesso

This amazing product will revolutionize the way you think about gesso. High quality gesso that will help you produce the highest quality work!

**\*\*Reformulated for great coverage!\*\***

### White Gesso

NUMBER	DESCRIPTION
120800	250ml white
120805	500ml white
120810	1000ml white
120815	1/2 gal white
120820	1gal white

### Black Gesso

NUMBER	DESCRIPTION
120850	500ml black
120860	1000ml black
120870	1gal black



### 3 simple tests to find out if YOUR gesso is of professional quality:

1. Pour a 4" thick pool of gesso on a disposable paper palette. Let it dry for 1 week. Peel off the gesso. Flex to look for cracks.
2. Paint several coats of gesso on a sheet of watercolor paper and let it dry for a few days. Pour linseed on the coated surface to see if it bleeds through.
3. Coat a canvas with gesso. Let it dry for a few days. Rub with a dark wet cloth to see if gesso has become permanent. Dark cloth should not show any white residue.



*A great multi-purpose, non-toxic cleaning agent!*



### Jack's Linseed Studio Soap

This may be the world's best brush cleaner...but it can also be used to clean your hands, floors, work surfaces, and just about anything else that needs cleaning.

- Safe, non-toxic, low odor
- Made from naturally refined linseed oil
- Special blend of natural cleaners
- Can clean dried acrylic or oil from a brush and even clothing

NUMBER	DESCRIPTION
120735	1 oz. (30ml)
120740	4 oz. (120ml)
120745	8 oz. (250ml)
120750	16 oz. (500ml)
120755	32 oz. (1000ml)
120736	Counter Display 24 - 30ml jars

### Kinstler Alkyd Painting Medium

More than just a paint thinner! This semi-synthetic polymer which significantly accelerates the drying time of oil colors can be mixed in any ratio to extend colors and is the ideal medium for creating transparent glazes. Dries to a tough yet flexible film, reinforces the coat's adherence and is virtually non-yellowing.

**NUMBER 119100 120ML**

### Kinstler Studio Painting Medium

Using Studio Painting Medium with professional grade oil paints will ensure the flow necessary to achieve the same luminous effects as are present in Kinstler's studio portraits.

**NUMBER 119110 120ML**



PAINT

professional



### High Viscosity Acrylics

This 92-colour line contains only the highest quality pigments selected for lightfastness and purity. Each colour is formulated to achieve maximum pigment concentration and colour strength consistent with good handling properties and stability. No fillers or extenders. Most colours dry to a natural gloss while those with larger pigment particles create a more satin finish.



### Liquid Acrylics

Provides the artist with a self-leveling, fluid paint ideal for high detail, glazing and watercolour-like techniques, without sacrificing colour strength or permanence. 99 colors.

mediums



### Sludge and Sludge Gesso

Sludge is a by-product of the acrylic paint manufacturing process. Sludge has the same handling qualities as regular acrylic paints and can be used as a paint, primer or paint medium. Recycled pigments also make great gesso! Tri Art utilizes recaptured pigments from the manufacturing process to create a high quality Gesso.



### Mediums

Tri Art Artist Mediums have been formulated in accompaniment with Tri Art Acrylic colours to provide the enterprising artist with the tools needed to create an endless possibility of texture, effects and finishes. Mediums are of archival quality.



**Solucryl**

Solucryl is the definitive educational paint. Priced to fit neatly into any budget, this economical palette of 20 colours is designed for use by anyone from school-aged children to seniors in a huge variety of applications. These colours are vibrant, virtually odorless, non-toxic and best of all, resoluble.



**Art Noise**

Art Noise is an academic acrylic designed for multipurpose use in the classroom. Made with 100% acrylic emulsion, this line of non-toxic permanent colours are made from the same materials as our artist quality paint. 24 colours.



**UVfx**

UVfx poster paint dries to a permanent, pliable matte or gloss finish. Colours are bright when applied, and glow under black lights! This non-toxic, low odor paint is available in ten colours and is made with 100% acrylic emulsion.



**Tempera**

Ten vibrant colours are created by using real pigments for optimum chroma. These temperas allow for excellent colour mixing not usually found in a tempera line. Superior flexibility and adhesion to surfaces without cracking or dusting often found in student temperas.

FOR A FULL LINE CATALOG: WWW.TRI-ART.CA

# PLAYCOLOR

- Easy to use, easy to clean up
- No water or cups required
- No paint brushes needed
- Won't wrinkle paper
- Bright, vibrant colors
- Quick-drying
- Won't crack when dry
- Easy to pack up and store in the tray that comes in each set
- Available in 3 sizes
- When pressing lightly, results resemble pastel; when pressing firmly, results look like a poster paint



Uncap, Twist and Paint!



## A. Playcolor Kids Sets

For drawing and painting in a fun, easy and clean way. For painting on paper, cardboard, posters, wood, etc. Instant application with no need for water or brushes.

NUMBER	DESCRIPTION
2610711	Set of 6
2610731	Set of 12

## B. Playcolor Mural Set

12 assorted colors.

NUMBER 2758331

## C. Playcolor Pocket Sets

Same great paint sets, except these fit in your pocket!

NUMBER	DESCRIPTION
2510511	Set of 6
2510521	Set of 12

## D. Playcolor Metallic Sets

NUMBER	DESCRIPTION
2510341	Set of 2 Pocket
2610391	Set of 2 Standard
2510351	Set of 6 Pocket
2610321	Set of 6 Standard

## E. Playcolor Metallic Mural

Contains 4 silver, 4 gold, 1 each of Metallic-Blue, Pink, Green, Purple.

NUMBER 2710962

# PLAYCOLOR®

## Textil



- Decorate fabrics
- Fast and easy
- Dries quickly
- Machine wash
- Use with stencils
- Smooth & creamy
- Heat seal for permanency



### Instructions For Use:

1. Fasten a piece of cardboard behind the area of fabric to be decorated.
2. Paint and decorate fabric to your style.
3. Once dry, place a sheet of paper on top of design and iron for 3-4 minutes until it sets.
4. Once set, it can be machine washed at up to 60°C/140°F.



### Playcolor Textile Sets

PlayColor that can be used on fabrics. Paint, then iron to fix the paint on the fabric and make it washable. Can be used on cotton, polyester and silk, etc.

NUMBER	DESCRIPTION	NUMBER	DESCRIPTION
2610401	Set of 6 Standard	2510501	Set of 6 Pocket
2610461	Set of 12 Standard	2510561	Set of 12 Pocket

PAINT

85

# PLAYCOLOR®

## FLUO

- UV Reactive
- Fast and easy
- Dries quickly
- 6 vivid colors

### PlayColor Fluorescent Sets

PlayColor in dazzling day-glow colors. PlayColor Fluo can be instantly applied, give excellent coverage and are very fast drying. Can also be used as highlighters.

NUMBER	DESCRIPTION
2510421	Set of 6 Pocket
2610431	Set of 6 Standard



www.richesonart.com

1.800.233.2404

# RICHESON TUBE PAINT SETS



PAINT

86

1.800.233.2404 www.richesonart.com

## Richeson Paint Sets

### 12ml Tubes

Richeson Paint Sets offer the beginning artist a great selection of color at a great price. The paints are made using only the finest materials available to ensure bright colors that mix well. All materials used are non-toxic. These paints and oil pastels are only sold in sets.

### A. ~~Acrylic Tube Sets~~

NUMBER	DESCRIPTION
420812	Set of 12
420818	Set of 18

### B. Watercolor Tube Sets

NUMBER	DESCRIPTION
411255	Set of 12
411253	Set of 18

### C. Oil Color Tube Sets

NUMBER	DESCRIPTION
411252	Set of 12
411251	Set of 18

### D. Gouache Tube Sets

NUMBER	DESCRIPTION
427312	Set of 12
427318	Set of 18

### E. Gouache Jar Set

This set includes 12 – 40ml plastic jars of the following colors: zinc white, yellow light, ochre yellow, red vermillion, alizarin crimson, iron oxide, prussian blue, emerald light, violet deep, green deep, mars brown, and carbon black.

NUMBER 38112

### F. ~~Richeson Oil Pastels~~

~~These oil pastels are a great way to combine your painting with your love of using pastels. They are easy to transport and save valuable time in cleanup!~~

NUMBER	DESCRIPTION
421225	Set of 16
421227	Set of 36
421228	Set of 60



F

# YARKA PAINT SETS



## Yarka™ Student Watercolor Sets

Yarka Student Watercolor Sets come in deep full-pans of 8, 10, and 12 color palettes. Once you have tried a semi-moist Yarka watercolor, you'll never want the extruded dry cake watercolors again.

NUMBER	DESCRIPTION
A. 38010	Set of 10
B. 38011	Set of 12
C. 38008	Set of 8

## D. Yarka™ Sets of 7.5ml tubes

Made from the finest pigments, these sets are great for the beginning painter who doesn't want to invest in larger tubes.

NUMBER	DESCRIPTION
33513	Watercolor Set of 12
33514	Oil Set of 12



## E. Watercolor Class Pack - 27

27 Sets of 8 Semi-Moist Watercolors and 1 pack of 9" x 12", 50 sheet, 135# watercolor paper.

**NUMBER 390327**

## F. Watercolor Class Pack - 36

36 Sets of 8 Semi-Moist Watercolors and 1 pack of 6" x 9", 50 sheet, 88# watercolor paper, 1 large color wheel and 1 30-pack of small color wheels.

**NUMBER 390336**



# RICHESON SEMI-MOIST WATERCOLORS

## Semi-Moist Watercolor Sets

Brilliant, bright colors. Semi-moist, so just a little bit of water is needed to easily lift the paint. Richly pigmented. The hinged cover can be used as a mixing palette. Excellent quality at an economical price. Back cover has a color mixing guide. Each set includes a brush.

NUMBER	DESCRIPTION
390008	Set of 8
390016	Set of 16
390112	Set of 12
390124	Set of 24
390210	Set of 10 Pearlescent
390220	Set of 20 Pearlescent



*Brilliant, rich  
semi-moist  
watercolors*

## Pearlescent Watercolor Set of 12

Intense, rich, semi-moist, pearlescent colors even adults love! Brush included. Non-toxic.

NUMBER 400120





# RICHESON PAINT SETS

## Collegiate Oval Sets

Finest quality opaque watercolors in a heavy-duty plastic tray with hinged cover. These are great for school and workshops. All sets include a brush.

NUMBER	DESCRIPTION
A. 400100	Set of 8
B. 400110	Set of 12
C. 400102	Set of 22

## D. Opaque Watercolor Set of 12

Fine quality opaque watercolors - 1-1/8" diameter. Colors are bright and ideal for school use. Plastic cases can hang on pegboard or be stacked on a shelf. Each set contains a brush.

NUMBER 400101

## E. Fluorescent/Primary Watercolor Set of 12

This set of 12 contains vibrant, opaque watercolors and includes a brush. It is packaged to hang on a pegboard.

NUMBER 400098 (6 Primary/6 Fluorescent)

## F. ~~Paint Palette With Handle~~

~~This opaque watercolor set comes with a handy carry handle and has a color guide on the back. Includes a brush. 21 colors.~~

NUMBER 400103

## G. Palette Shaped Set

The palette shaped tray has 12 small buttons of watercolor and a brush. There is no cover.

NUMBER 400112

## H. Jackson Juniors Miniature Watercolor Set Display

This attractive counter display holds 36 miniature watercolor sets of 8 pan colors. Brush included.

NUMBER 400079-36

Perfect point-of-purchase display!



All paints on this page are tested in accordance to: ASTM D-4236 and bear safety labels to the standards issued by ACMI.

# RICHESON PAINTS

## ~~Richeson Opaque Watercolor Sets~~

~~These watercolor sets contain the finest opaque watercolors plus a brush and a tube of opaque white. The high pigment concentration offers the artist strong, rich color.~~

### ~~NUMBER DESCRIPTION~~

- ~~A. 400108 Set of 12  
B. 400109 Set of 24~~

## c. Metal Case Watercolor Set

A set of twelve 1-3/8" x 5/8" brilliant pan watercolors in a metal case. Brush included.

NUMBER 400099



PAINT

90



## Richeson Powder Paint

Powder Paint is convenient and easy to use! Just mix equal parts of Powder Paint and water and you're ready to get painting. For thinner washes add more water; for thicker, more rich colors add a bit less water. Available in 1lb. containers.

Caution: Pigments may stain. We recommend wearing an apron during use.



www.richesonart.com

1.800.233.2404

# RICHESON TEMPERA BLOCKS

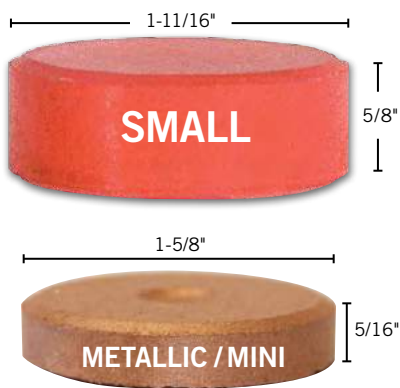
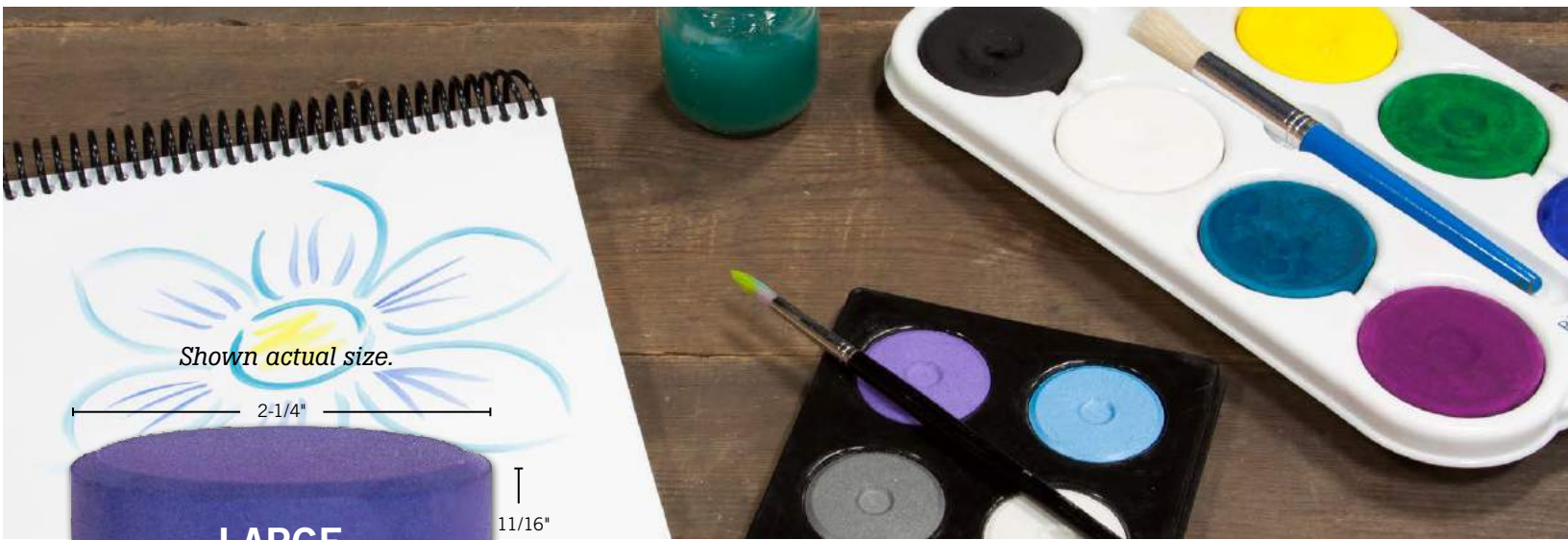

- Solid, convenient source of brilliant, opaque watercolor
- Ideal for distribution and collection in the classroom
- Will not deteriorate in storage and are instantly useable with the addition of water.
- Appropriate colors can be mixed to produce beautiful intermediate hues.

## Instructions for use:

Apply water to the surface of the block and, with the aid of a brush, work up the color to a smooth consistency. As with all opaque watercolor, always apply to highly absorbent surfaces, such as paper, to ensure good adhesion.

## Large and Mini Tempera Packs of 6



Black  
Large 101292  
Mini 101609



Brilliant Blue  
Large 101293  
Mini 101601



Brilliant Green  
Large 101294  
Mini 101604



Orange  
Large 101295  
Mini 101605



Crimson  
Large 101296



White  
Large 101297  
Mini 101608



Brilliant Yellow  
Large 101298  
Mini 101602



Vermillion Hue  
Large 101320



Yellow Ochre  
Large 101321



Burnt Sienna  
Large 101323



Brilliant Red  
Large 101324  
Mini 101603



Turquoise  
Large 101325  
Mini 101610



Purple  
Large 101326  
Mini 101606



Burnt Umber  
Large 101327  
Mini 101607



Gamboge Hue  
Large 101329



Violet  
Large 101331  
Mini 101611



Cobalt Hue  
Large 101333



Cerise  
Large 101334



Leaf Green  
Large 101338



## Metallic Tempera Packs of 6



Metallic Gold  
101101

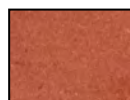

Metallic Copper  
101102

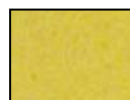

Met. Yellow Gold  
101103

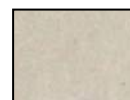

Metallic Mirror  
101104



Met. Charcoal  
101105



Met. Aquamarine  
101106



Metallic Blue  
101107

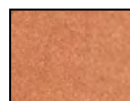

Metallic Dp. Gold  
101108



Metallic Orchid  
101109

# RICHESON TEMPERA BLOCKS



PAINT

92

www.richesonart.com

1.800.233.2404

## A. Large Tempera Sets

NUMBER	DESCRIPTION
101259	Set of 6 in "Lock Box" Primary colors plus black, white & green
101260	Set of 6 in Plastic Tray Primary colors plus black, white & green
101262	Set of 6 Shrink Wrapped Primary colors plus black, white & green
101266	Set of 6 Shrink Wrapped, Secondary
101267	Set of 6 in Plastic Tray, Secondary
101268	Set of 9 color refill pack

## B. Small Tempera Sets

NUMBER	DESCRIPTION
101227	Set of 6 Fluorescent Blocks in Plastic Tray
101264	Set of 6 in Plastic Tray Primary colors plus black, white & green

## C. Metallic Tempera Sets

NUMBER	DESCRIPTION
101120	Set of 6 Metallic Blocks in Plastic Tray
101130	Set of 9 Metallic Blocks in Plastic Tray

## D. Mini Tempera Sets

NUMBER	DESCRIPTION
101620	Set of 6 in plastic tray
101625	Set of 6 Fluorescent colors
101630	Set of 9 Mini Blocks in Plastic Tray
101635	Set of 9 Multicultural
101640	Set of 6 color refill pack
101650	Set of 9 color refill pack

**See page 161 for other  
Tempera Cake Trays!**

## E. Tempera Block Sets in Trays & Racks

NUMBER	DESCRIPTION
101418	Set of 8 in plastic tray with brush
101436	Set of 6 tempera trays in rack (6 filled trays w/brush)
101496	Set of 12 tempera trays in rack (filled trays w/brush)
101400	Empty 12 slot tempera rack
101408-12	Empty 8-well tray (pack/12)

## F. Tempera Cake Sets in Muffin Trays

Vibrant tempera cake paints available in heavy-duty muffin tray sets.

NUMBER	DESCRIPTION
101361	Set of 6 - Primary
101362	Set of 9 - Complete
101363	Set of 6 - Secondary

# UNISON SOFT PASTELS

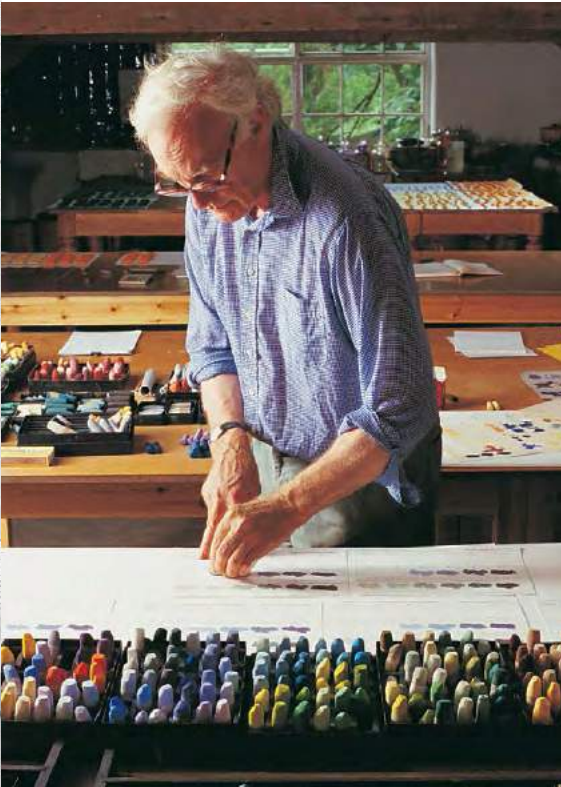

- Professional, high quality
- Water-soluble
- Hand rolled and air dried
- Smooth, buttery texture
- Consistency of response
- Wide spectrum of colours
- Intensely pigmented colour
- Superior lightfastness

*In the hills of Northumberland, England, an artisan makes pastels. He mixes pigments in equipment a baker would use. He lightly hand-rolls the dough and allows the sticks to air-dry.*

Out of frustration with the pastels available, British artist, John Hersey, began making handmade pastels. Developed to be superior in colour, texture and response, Unison Soft Pastels are unlike anything on the market today. John Hersey worked out his unique colour formulations over a decade of experimentation, creating intense, vibrant colours, blended almost exclusively from pure pigment and water.

Hersey had been using soft charcoal for years and loved the texture of the medium and the boldness of the absolute black it offered. His work in black and white gave him a keen awareness of light and shadow. He wanted to translate that awareness to the use of colour. But he could not find pastels that suited him in either performance or colour. In pastel factories, pigments are mixed with water, gums and other additives in large mechani-

cal mixers. The pastel "dough" is pushed through the barrel of an extruder by a long revolving screw. The solid dough is forced through a circular opening at the extruder's end. It emerges from the extruder like a long pencil and is cut to stick lengths. The sticks then drop onto a conveyor belt to go through a drying operation and then are wrapped. "The problem with the extrusion process," Hersey said, "is that it squeezes the pastels very tight and compresses them." They are probably overheated in drying as well. This makes them hard, on the whole. It alters their consistency

and alters their response to being used. "In our hand-made process, the pigment hardly gets pressed at all. The sticks are rolled lightly. It makes them very fluent when you use them. Like soft charcoal."

Creating consistency of response across the colour spectrum was a particularly thorny problem for Hersey. All pigments vary in their physical properties. Many pigments will hold together after being mixed with water, rolled and dried. Others fall to pieces. For those, a little weak starch or gum is added to give the best response without interfering with the colour.



# UNISON SOFT PASTELS

Unison Pastels actual size.



Standard Size 740...

Medium Size 741... & Jumbo Size 742  
Available by special order only.

Painting by Brenda Mattson  
www.brendamattson.com



## Individually Boxed

Each stick is individually packaged to eliminate product handling, damage and dust. Each hanging carton contains a foam insert to protect the pastel from breakage. The back panel displays handling information, UPC code, colour, and product number, easily identifying all important information according to ACMI regulations. Discover the value and convenience of individually packaged Unison Soft Pastels!

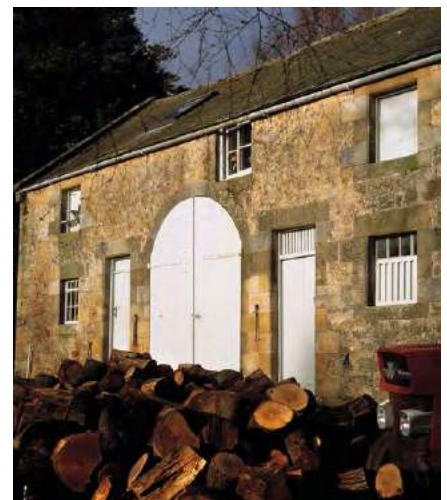

Many of the colours are pure and single pigments. For more complex colours, up to five pigments may be mixed to attain the perfect hue. Unison blends in very little white or

a colouristic whole. Instead, Hersey took colours and created cycles of related hues, to reflect the unison he saw in nature. Thus the name of his company: Unison Colour.

"I worked it out so that the cycles work in terms of how your eye sees things," Hersey said. "It's not just theory. In nature, one sees centers of intense colour and all the variations of that colour until it gets so weak or so influenced by something else that it becomes another colour. Stable colour does not exist.

It's an illusion of the sun. You look out the window, you'll find that what was a beautiful pale green is now a dark blueish green. Colour in nature is changing all the time. These changes are what I am trying to illustrate in my colour sets. Of course it's not complete. If you are going to make pastels to illustrate the entire universe, you're going to make millions of pastels."

Hersey found inspiration in his surroundings. He was originally from the south of England, which he described as foggy and misty, with poor light for an artist. The light in Northumberland, where he later lived, was particular. "It's Roman light up here," he said. "Very brilliant, incandescent and radiant. Like the works of Poussin and Claude Lorraine. Even if you drive south one hundred and fifty miles from here, all the colours begin to fade. Light has been an enormous influence for me."



chalk. Artists are generally looking for intense and dark pastels. You can get sick of the endless arrays of pale pastel shades, and you want some really strong colours. Those pastels are just pigment and nothing else.

Most manufacturers make up their sets of colours by the simple addition of either black or white to the pigment mix. That practice results, Hersey contended, in isolated series of stepped reductions or tints, having no reference to

# UNISON SOFT PASTEL SETS

Discover the intensity, vibrancy, and responsiveness of Unison!

## Unison Sets of 8

NUMBER	DESCRIPTION
740329	Sampler-Set
740335	Shadow-Set
740827	Portrait-Caucasian-Set
740828	Portrait-African-Set
740829	Portrait-Asian-Set
740830	Portrait-Native-American-Set
740831	Portrait-Mediterranean-Set
740832	Portrait-Latino-Set
740833	Portrait-Eyes-Set
740834	Desert-Sunset-Set
740835	Polar-Ocean-Set
740836	Northern-Sunrise-Set
740837	Tropical-Ocean-Set
740840	Starter-Set
740841	Dark-Set
740842	Light-Set
740843	Bright-Set

## Unison Sets of 18

NUMBER	DESCRIPTION
740271	Red-Values
740272	Red-Earth-Values
740273	Yellow-Gold-Values
740274	Brown-Earth-Values 1 (1-18)
740283	Brown-Earth-Values 2 (19-36)
740275	Green-Values 1 (1-18)
740276	Green-Values 2 (19-36)
740277	Blue-Green-Earth-Values
740278	Yellow-Green-Earth-Values
740279	Blue-Violet-Values
740280	Blue-Green-Values
740281	Grey-Values 1 (1-18)
740282	Grey-Values 2
740289	Orange-Values
740300	Additional-Values 1 (1-18)
740301	Additional-Values 2 (19-36)
740302	Additional-Values 3 (37-54)
740321	Dark-Values 1 (1-18)
740340	Dark-Values 2
740342	Light-Values
740346	Natural-Earth
740347	John's-Set
740284	Starter-Colors
740285	Portrait-Colors
740287	Landscape-Colors
740326	Southwestern-Colors
740401	Daniel-Greene-Set
740540	Special-Collection-Colors

## Unison Sets of 36

NUMBER	DESCRIPTION
740292	Starter-Colors
740286	Portrait-Colors
740288	Landscape-Colors
740341	Dark-Values
740400	Daniel-Greene-Set

## Unison Sets of 72

NUMBER	DESCRIPTION
740293	Portrait-Colors
740294	Landscape-Colors
740310	Starter-Colors
740320	Stephen-Quiller

## Unison Half Stick Sets

NUMBER	DESCRIPTION
740900	Set of 16 Starter-Colors
740905	Set of 30 Starter-Colors
740910	Set of 63 Starter-Colors
740915	Set of 120 Starter-Colors

For set contents, visit our web site at [www.richesonart.com](http://www.richesonart.com)

**Red Values Set #740271**



**Red Earth Values Set #740272**



**Brown Earth Values 1-18 Set #740274, 19-36 Set #740283**



**Natural Earth Values Set #740346**

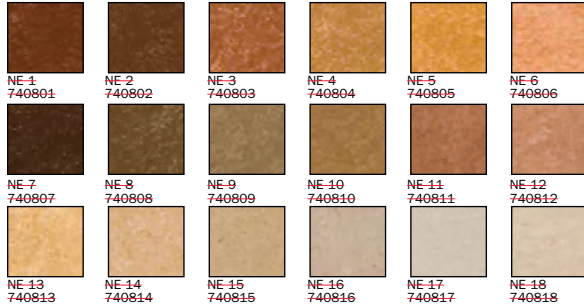

**Orange Values Set #740289**

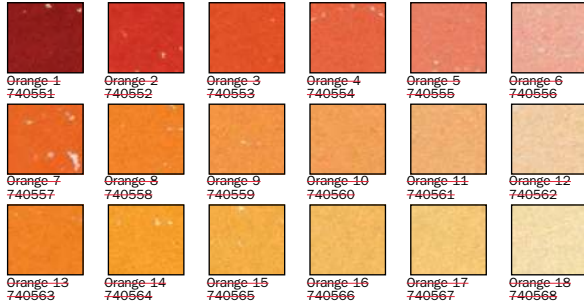

Unison Pastels are tested in accordance to ASTM-D 4236 and bear safety labels to the standards issued by ACMI. Unison colours are marked with the CL label and appropriate safety warnings.

**Yellow Gold Values Set #740273**



**Yellow Green Earth Values Set #740278**

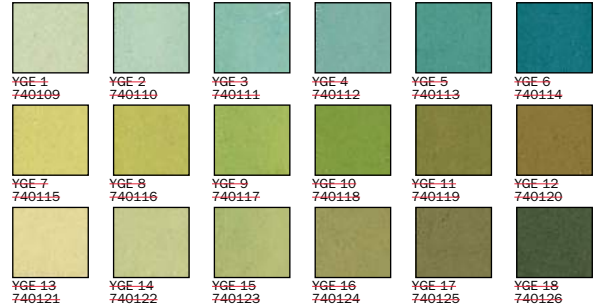

**Green Values 1-19 Set #740275, 19-36 Set #740276**



**Blue Green Earth Values Set #740277**



**Turquoise Values found in the Southwest Set #740326**

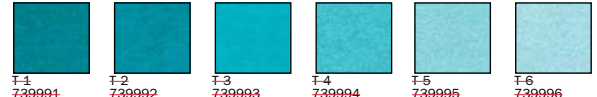



**Blue Green Values Set #740280**



**Blue Violet Values Set #740279**



**Grey Values 1-18 Set #740281, 19-36 Set #740282**



**Special Collection Set #740540**

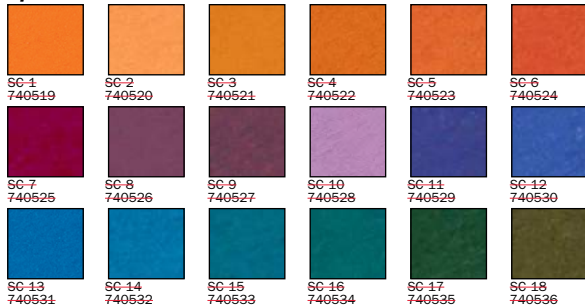

**Portrait Colors found in Set #740293**

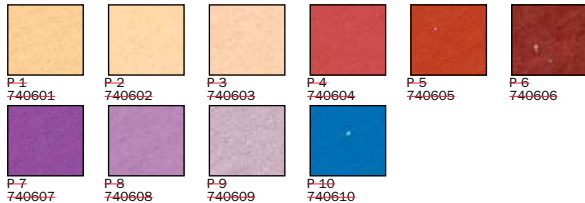

**Additional Values 1-18 #740300, 19-36 #740301, 37-54 #740302**



**Dark Values Set #740321**

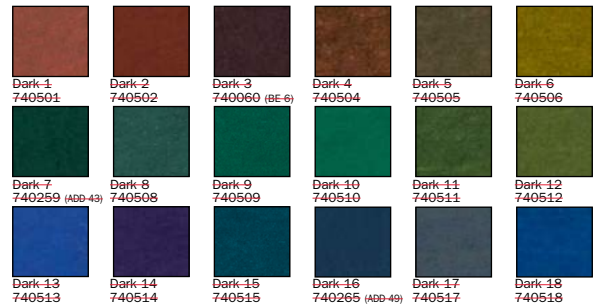

**Light Values Set #740342**

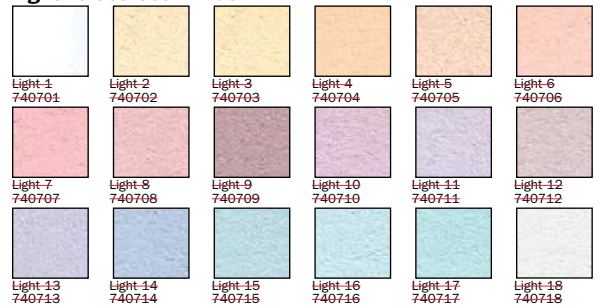

**Dark Values found in Dark 2 Set #740340:**

- #740024 - RE 6
- #740013 - RED 13
- #740060 - BE 6
- #740072 - BE 18
- #740240 - A 24
- #740253 - A 37
- #740259 - A 43
- #740073 - GREEN 1
- #740085 - GREEN 13
- #740144 - BGE 18
- #740126 - YGE 18
- #740215 - GREY 35
- #740265 - A 49
- #740168 - BV 6
- #740180 - BV 18
- #740245 - A 29
- #740252 - A 36
- #740193 - GREY 13



# UNISON SOFT PASTELS

## John's Set #740347

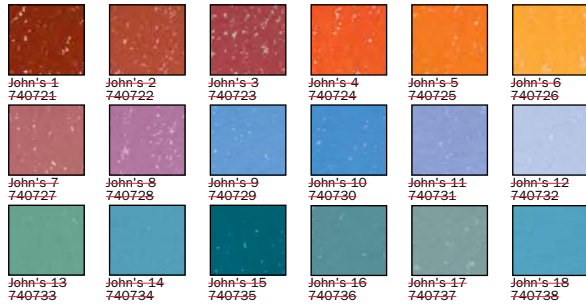

## Introducing NEW COLORS!

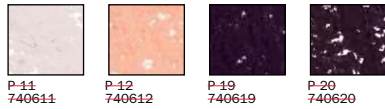

## D. ~~Empty Boxes and Foam Inserts~~

NUMBER	DESCRIPTION
740298	18-piece box with foam
740322	36-piece box with foam
740317	72-piece box with foam
740391	18-piece foam inserts
740393	72-piece foam inserts

\*Foam and boxes may have flaws and some residual color. We occasionally convert sets to open stock and make the empty boxes available for a nominal price for artists wishing for extra storage.



## Handmade Color Charts

NUMBER 740309

PASTELS

98

www.richesonart.com

1.800.233.2404

### A. ~~Oak Spinning Display Case~~

The rack is mounted onto a stainless steel rotating plate, that easily holds up to 500lbs., and one panel of the upper area opens to offer four shelves of storage. The filled display includes three each of 420 colors, 420 hooks and 25 printed color charts.

- Has 3" heavy-duty casters
- Height: 69", width: 18", depth: 18"
- Bottom storage: 15-1/2" high
- 11 beveled rows for hooks

NUMBER	DESCRIPTION
740365	Spinning Rack Filled
740330	Spinning Rack Empty

### B. ~~Flat Unison Pastel Rack~~

Contains four each of 84 colors. Includes a full color header and enough hooks to hang seven rows of 12.

- Height: 31"
- Height with header: 38"
- Base width: 17-1/2"
- Base depth: 16"
- 7 beveled rows for hooks

NUMBER 740308

### C. ~~84 Piece Assortment~~

NUMBER 740311 (NO RACK)

### D. ~~420 Piece Assortment~~

NUMBER 740360 (NO RACK)

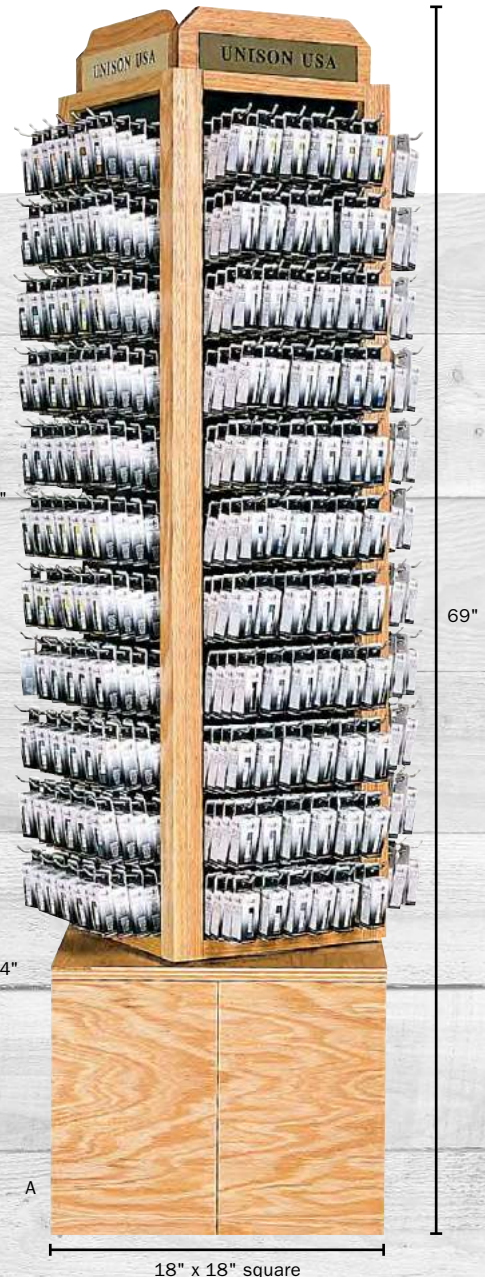

69"

30-1/4"

A

B

18" x 18" square

# RICHESON SIGNATURE PASTELS



Easy way to try them all!

Our Richeson Signature Pastels are appropriate for every level of skill and creativity. They are versatile, vibrant, and well-made. They are perfect for all paintings from sketching to the final touches.

We are bringing you three different types of pastels to complete your selection.

The soft handmade pastels offer a consistent application without crumbling as some softer pastels do. The soft round pastels help you create broad smooth strokes or fine details. The Richeson Semi-Hard Pastels are perfect for underpainting and have great flat edges for shading.

**A. Half Stick Sampler Set of 18**  
Assorted colors  
**NUMBER 427340**

## Foundation Sets

These pastel sets are the perfect blend of functional drawing tools. Each set contains:

- 12 half sticks of handmade pastels
- 12 half sticks of medium-soft pastels
- 12 half sticks of semi-hard pastels
- 2 squares of professional grade white and black
- 1 charcoal pencil
- 1 kneaded eraser
- 2 stumps
- 1 chamois
- 1 pencil sharpener

**NUMBER 427350** Portrait  
**NUMBER 427351** Landscape  
**NUMBER 427352** Basic



# RICHESON SIGNATURE PASTELS

PASTELS

100

www.richesonart.com

1.800.233.2404

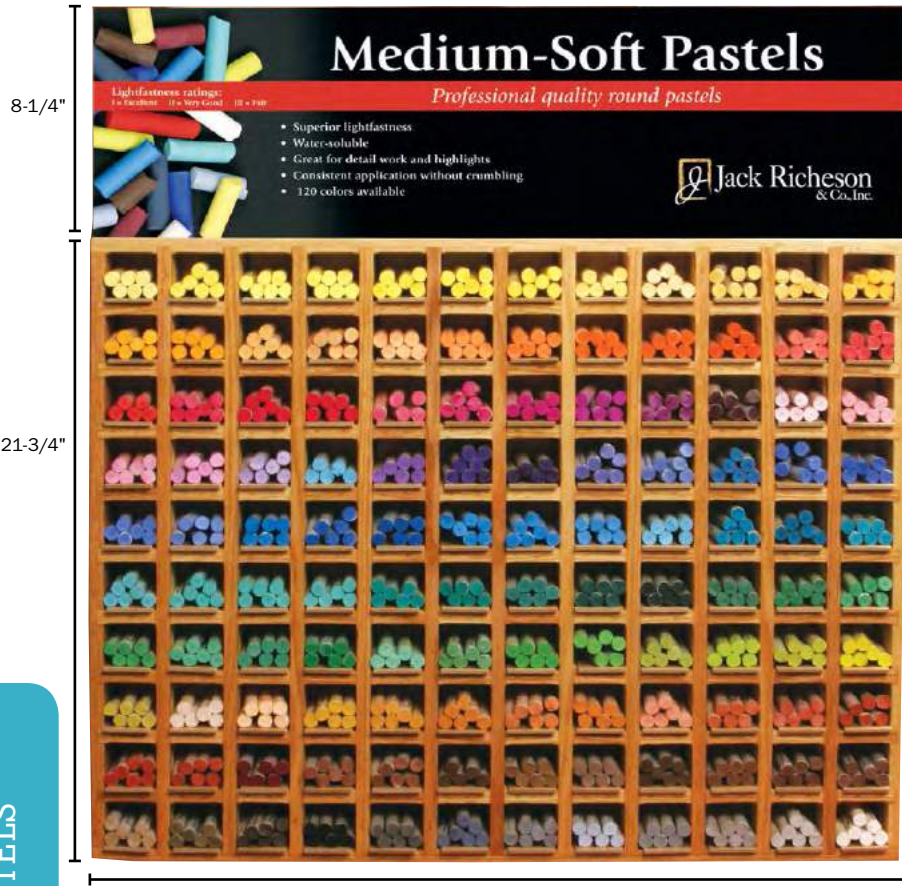

**Flat Rack**

27-1/2"



**Counter Spinner**

18"

## Richeson Signature Pastel Racks

Once again Jack Richeson is giving you options to help use your floor and shelf space for optimal selling opportunities! Our displays can accommodate any space you have available and each hold 120 colors. They are attractive, functional and really showcase these great products. They are available for all pastels in either a Flat Shelf Unit or a Spinning Counter Unit. You have the flexibility to determine what is best for you!

### Flat Racks

#### ~~Semi-hard Square Pastel~~

##### ~~Flat Rack~~

~~NUMBER 425500~~

~~Contains 12 each of 120 colors of semi-hard pastels.~~

#### ~~Round Pastel Flat Rack~~

~~NUMBER 426500~~

~~Contains 6 each of 120 colors of medium-soft pastels.~~

#### ~~Handmade Pastel Flat Rack~~

~~NUMBER 424500~~

~~Contains 3 each of 120 colors of handmade pastels.~~

### Spinning Counter Racks

#### ~~Semi-Hard Square Pastel~~

##### ~~Spinning Rack~~

~~NUMBER 425501~~

~~Contains 12 each of 120 colors of semi-hard pastels.~~

#### ~~Round Pastel Spinning Rack~~

~~NUMBER 426501~~

~~Contains 6 each of 120 colors of medium-soft pastels.~~

#### ~~Handmade Pastels Spinning Rack~~

~~NUMBER 424501~~

~~Contains 3 each of 120 colors of handmade pastels.~~

### ~~Ultimate Spinner — Uses 2 Square Feet of Floor Space!~~

~~Spinner is a compact way to display 120 each Richeson Hand-Rolled, Medium-Soft, and Semi-Hard Pastels using only two square feet of floor space! Holds a total of 360 pastels.~~

~~NUMBER 427455 FILLED~~

~~NUMBER 427450 EMPTY~~



**Floor Spinner**

Base:  
24" x 24"

# RICHESON SIGNATURE PASTELS

Richeson Pastels can be ordered by using the following prefix and the last three numbers listed under each color.

**424... Handmade Soft Pastels** (order in qty of 3)  
**425... Semi-hard Pastels** (order in qty of 6)  
**426... Medium-soft Pastels** (order in qty of 6)

# RICHESON SIGNATURE PASTEL SETS

## Richeson Handmade Soft Pastels

- Superior lightfastness, professional quality
- Create broad smooth strokes or fine detail
- 33% larger than most pastels on the market
- Full-size stick: 2-3/4" x 5/8"  
Half-size stick: 1-3/8" x 5/8"
- Perfect for velvety finish work
- Offers consistent application without crumbling
- Superior selection – 120 colors available in sets of 6, 18, 24, 36, 48, 72 and 120

## Full Stick Sets Sets of 18

- NUMBER 427319 Assorted  
NUMBER 427320 Portrait  
NUMBER 427321 Landscape

## Sets of 36

- NUMBER 427322 Assorted  
NUMBER 427323 Portrait  
NUMBER 427324 Landscape

## Set of 72

- NUMBER 427325 Assorted

## Sets of 120

- NUMBER 427326 Assorted

## Half Stick Sets

### Set of 6

- NUMBER 427505 Assorted

### Sets of 24

- NUMBER 427515 Assorted

### Set of 48

- NUMBER 427520 Assorted

### Sets of 120

- NUMBER 427530 All colors



# RICHESON SIGNATURE PASTEL SETS

## Richeson Medium-Soft Pastels

- Superior lightfastness, professional quality
- Full-size stick: 2-3/4" x 1/2"; Half-size stick: 1-3/8" x 1/2"
- Perfect for the middle layers of a painting
- Offers consistent application without crumbling
- Superior selection – 120 colors available in a variety of sets

### Full Stick Sets

#### Set of 15

NUMBER 4290150 Assorted



#### Sets of 30

NUMBER 4290300 Assorted  
NUMBER 4290301 Landscape  
NUMBER 4290302 Portrait



#### Sets of 45

NUMBER 4290450 Assorted  
NUMBER 4290451 Landscape  
NUMBER 4290452 Portrait



#### Set of 60

NUMBER 4290600 Assorted

#### Set of 120

NUMBER 4291200 All-colors

### Half Stick Sets

#### Set of 6

NUMBER 4280060 Assorted

#### Set of 15

NUMBER 4280150 Assorted

#### Set of 30

NUMBER 4280300 Assorted

#### Set of 45

NUMBER 4280450 Assorted

#### Set of 60

NUMBER 4280600 Assorted

#### Set of 120

NUMBER 4281200 All colors



## Richeson Semi-hard Square Pastels

- Superior lightfastness
- Perfect for under painting
- Size: 3-5/8" x 1/4"
- Flat edge for shading
- Will sharpen to a point
- Offers crisp, hard edge without crumbling
- Superior selection – 120 colors available in sets of 12, 18, 36, 72 and 120

#### Set of 12

NUMBER 427339

#### Set of 18

NUMBER 427335

#### Set of 36

NUMBER 427336

#### Set of 72

NUMBER 427337

#### Set of 120

NUMBER 427338



# STREET Stix



## Street Stix

60 colors available in open stock and sets

- 2-3/4" x 1/4" sticks
- Ideal for murals and outdoor surfaces
- Perfect for festivals & outdoor events
- Highly pigmented colors
- Blend beautifully
- Rain-durable

PASTELS

16-1/2"

104



4-1/2"

29-5/8"

## STREET STIX

60 colors available in open stock and sets.

- 2-3/4" x 7/8" sticks
- Ideal for murals, urban art, and use on outdoor surfaces
- Highly pigmented colors
- Blend beautifully
- Rain-durable

ITEM	DESCRIPTION
423...	Open Stock (order in 3pc quantity of a color)
427365	Set of 3
427370	Set of 6
427375	Set of 12
423500	Filled Display (3 each of 60 colors)







Perfect for Festivals,  
Outdoor Events,  
Chalkboard Signs  
& Urban Art!

# STREET STIX

PAVEMENT  
PASTELS



<b>423001</b> 171 Grey	<b>423007</b> 168 Grey	<b>423010</b> 165 Grey	<b>423016</b> 169 Grey	<b>423019</b> 174 Grey	<b>423022</b> 167 Grey	<b>423025</b> 181 Grey	<b>423037</b> 155 Earth	<b>423046</b> 151 Earth	<b>423055</b> 147 Earth
<b>423064</b> 201 Earth	<b>423073</b> 102 Earth	<b>423082</b> 107 Earth	<b>423085</b> 104 Earth	<b>423088</b> 110 Earth	<b>423103</b> 141 Earth	<b>423115</b> 108 Yellow	<b>423124</b> 095 Yellow	<b>423124</b> 070 Yellow	<b>423130</b> 083 Yellow
<b>423139</b> 072 Yellow	<b>423142</b> 067 Yellow	<b>423151</b> 069 Yellow	<b>423154</b> 080 Yellow	<b>423157</b> 076 Yellow	<b>423163</b> 074 Yellow	<b>423172</b> 082 Green	<b>423178</b> 022 Green	<b>423181</b> 011 Green	<b>423184</b> 005 Green
<b>423187</b> 006 Green	<b>423190</b> 021 Green	<b>423202</b> 023 Green	<b>423205</b> 008 Green	<b>423211</b> 010 Green	<b>423214</b> 002 Green	<b>423217</b> 029 Green	<b>423220</b> 026 Green	<b>423223</b> 012 Green	<b>423226</b> 014 Green
<b>423232</b> 031 Green	<b>423247</b> 033 Blue	<b>423253</b> 048 Blue	<b>423259</b> 050 Blue	<b>423271</b> 058 Blue	<b>423283</b> 035 Blue	<b>423289</b> 261 Blue	<b>423292</b> 055 Blue	<b>423295</b> 064 Blue	<b>423298</b> 065 Blue
<b>423304</b> 060 Blue	<b>423307</b> 061 Blue	<b>423316</b> 075 Red	<b>423325</b> 134 Red	<b>423337</b> 142 Red	<b>423340</b> 221 Red	<b>423343</b> 062 Red	<b>423349</b> 135 Red	<b>423352</b> 131 Red	<b>423358</b> 137 Red

PASTELS

105

# JACKSON PASTELS



PASTELS

106

## Jackson Pastel Sets

Soft, square pastels of fine quality, these sticks are set into a plastic tray for protection and packaged in an attractive plastic case. A marvelous tool for drawing and sketching. A square stick that provides a new dimension in drawing. These pastel sticks are available in sets only.

NUMBER	DESCRIPTION
400105	Assorted Set of 12
400106	Assorted Set of 24
400107	Assorted Set of 48
400152	Assorted Set of 48
400160	Assorted Set of 144
400139	Landscape Set of 12
400153	Portrait Set of 12
400154	Portrait Set of 24
400157	Landscape Set of 24
400159	Earthtone Set of 12

## Jackson Pastel Sketch Stick Sets of 12

Pastel sets designed for sketching! Beautiful sets containing the sought after greys, sanguine and sepia. Colors essential to sketching. Excellent blending!

NUMBER	DESCRIPTION
400123	Black
400129	Sanguine-Light
400130	Sepia-Light
400134	Asst. Greys
400135	White
400136	Sepia-Dark
400137	Sanguine-Dark
400138	Sang. & Sepia



1.800.233.2404 www.richesonart.com



Jackson Pastels are tested in accordance to: ASTM D-4236 and bear safety labels to the standards issued by ACMI.  
**Prop 65 Compliant.**

# PASTEL STORAGE & SETS

## The Roz Boxes

- Equipped with comfortable handles and secure clasps
- Feature plastic Pastel Organizer Trays complete with foam inserts for ultimate protection

### A. The Roz Box

Includes 4 of the Pastel Organizer Trays and can hold up to 136 pastels. Dimensions: 17-3/8"(w) x 14-3/4"(d) x 2-3/4"(h)

**NUMBER 400280** (Pastels not included.)

### B. The Roz Box 2

Includes 2 Pastel Organizer Trays and holds 68 pastels. Dimensions: 17-3/8"(w) x 7-3/4"(d) x 2-3/4"(h)

**NUMBER 400282** (Pastels not included.)

### C. The Pastel Organizer Trays

These trays are designed to fit in The Roz Box, The Roz Box 2, The Roz Bag or the ArtBin® Pastel 3 Box. Each stackable tray features a center grip for easy pickup. Dimensions: 16-3/4"(w) x 6-7/8"(d) x 7/8"(h)  
Slot dimensions: 7/8"(w) x 3-1/4"(d) x 3/4"(h)

**NUMBER 400281** Each tray holds 34 pastels

### D. The Roz Bag

The Roz Bag, made of lightweight fabric, has two separate compartments. The lower section can hold four Pastel Organizer Trays while the upper section is a convenient place to store a variety of tools. With its built-in elastic band, it can hold one more Pastel Organizer Tray. There are two pockets on either side of the bag to hold smaller items. This bag is equipped with an adjustable shoulder strap with a shoulder pad for comfort. Dimensions: 18" x 8" x 6".

**NUMBER 400284** With 4 Pastel Trays



### E. Empty Wooden Pastel Case

This compact carry case offers incredible storage for pastels and other materials plus extended work space! Comes with two pieces of foam that fit into the top lids for protection of your pastels. (Slotted foam for inserting pastels sold separately.)

**NUMBER 696210**

# DRAWING STICKS, SAUCE & PASTELS



PASTELS

108

www.richesonart.com  
1.800.233.2404

## Yarka™ Pastels by Richeson

Yarka Pastels are available in wooden boxed sets. The formulation process features durable, finely ground mineral and earth pigments. These high quality pigments are then combined with just the right amount of kaolin and Chasov Yar clay. Water-soluble Yarka Pastels feature a velvety response in 60 colors.

NUMBER	DESCRIPTION
19010	Set of 12 Landscape
19020	Set of 12 Portrait
19030	Set of 30
19060	Set of 60

## Yarka™ Sanguine and Sepia Drawing Sticks Wood Box Sets of 20

Yarka Sanguine and Sepia, are made from high grade pigments and Chasov Yar clay. These water-soluble, monochromatic crayons are best used on drawing paper or primed canvas.

NUMBER	DESCRIPTION
19411	5 sticks each color (dark & light)

## Sauce Drawing Sticks by Richeson

This is a medium from the Dark Ages: few of today's painters have had the opportunity to work with it. Sauce was a nearly-extinct medium that offered a full ten value tonal range. It is a stick much like a soft pastel, but when applied to paper, it gives a sensation of warm silk, slightly greasy but not oily. Breaking the Sauce down into its powder form can add to the versatility of its use. Each wooden boxed set contains 10 sticks which measure: 7/16" x 2-1/2".

NUMBER 19311 (1 stick each color)



## Stamps

These stamps are made of tightly spiral-wound, soft grey paper. Both ends can be used to smooth and blend pastels or charcoal.

### SIZES

- Size #1: 3/16" x 4-1/2"
- Size #2: 1/4" x 4-11/16"
- Size #3: 5/16" x 5"
- Size #4: 3/8" x 5-1/8"
- Size #6: 1/2" x 5-3/4"
- Size #8: 5/8" x 6-3/4"

### NUMBER DESCRIPTION

- 710201 Size #1 (12pcs)
- 710202 Size #2 (12pcs)
- 710203 Size #3 (12pcs)
- 710204 Size #4 (12pcs)
- 710205 Size #6 (12pcs)
- 710206 Size #8 (12pcs)
- 710207 Set of 5 (#1, #2, #4, #6, #8)
- 710304 Size #1 (3pcs)
- 710305 Size #2 (3pcs)
- 710306 Size #3 (3pcs)
- 710307 Size #4 (3pcs)
- 710308 Size #6 (3pcs)
- 710309 Size #8 (3pcs)
- 710310 Set of 3 (#1, #3, #8)
- 710311 Set of 3 (#2, #4, #6)

## Tortillions

Spiral-wound with one pointed end that can be cleaned or sharpened by tearing a strip off the top. Used for smoothing and blending pastel or charcoal.

### SIZES

- Small: 1/4" x 2-7/8"
- Medium: 5/16" x 3-1/8"
- Large: 3/8" x 3-5/8"

### NUMBER DESCRIPTION

- 710300 Class Pack (144 pcs - 48 ea, S,M,L)
- 710301 Small (12pcs)
- 710302 Medium (12pcs)
- 710303 Large (12pcs)
- 710312 Large (6pcs)
- 710313 Medium (6pcs)
- 710314 Small (6pcs)
- 710315 Set of 3 (1 of each size)
- 710316 Set of 6 (2 of each size)
- 710317 Set of 10 (Stamps/Tortillions)



These products are tested in accordance to: ASTM D-4236 and bear safety labels to the standards issued by ACMI.

# CHARCOAL

## Sand Pads

Sand paper sheets for sharpening pencils, pastels or charcoal.

**NUMBER 694006-12 (PACK OF 12)**

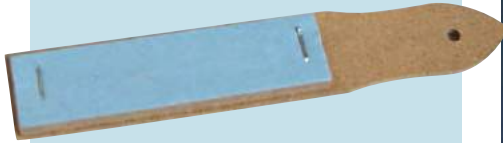

## Charcoal Holder

This tool will help keep you clean while you draw. It accommodates a variety of different sized and shaped sticks, but may need some modification to hold very small charcoal.

**NUMBER 210541**



## Artist Chamois

This chamois can be used wet for refining surfaces and wet finishing, or can be used dry for polishing and buffing. Approximately 5"x 7".

**NUMBER 710210 (INDIVIDUAL)**

**NUMBER 710260 (PACK OF 2)**

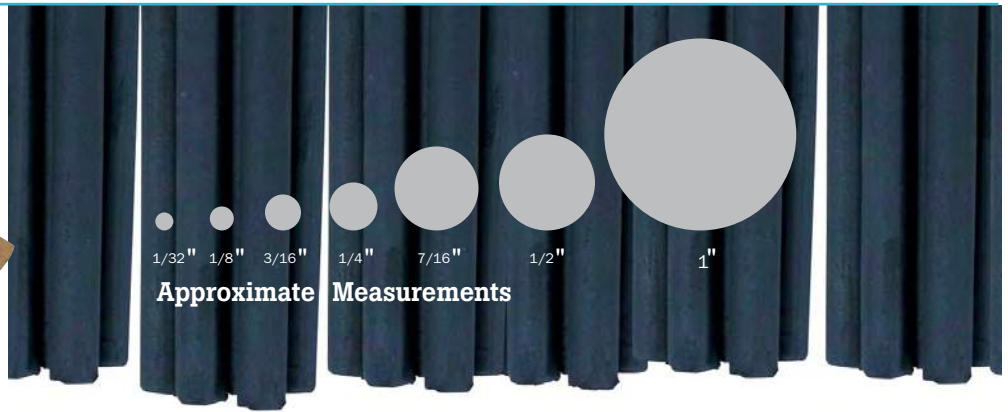

1/32" 1/8" 3/16" 1/4" 7/16" 1/2" 1"  
**Approximate Measurements**



## Richeson Charcoal

Designed for the professional artist, draftsman and architect. The selection of raw materials, texture, hardness and size were studied to guarantee the finest drawing and sketching material available for the professional.

## Natural Vine Charcoal

Natural Vine Charcoal sticks are cut to 6" in length in a variety of widths.

NUMBER	DESCRIPTION	WIDTH
870002	Thin Soft (25/box)	3/16"
870006	Regular Med (5/box)	3/16"
870009	Jumbo Soft (25/box)	7/16"
870017	Thin Medium (50/box)	3/16"
870030	Thin Soft (3/bag)	3/16"
870031	Thin Hard (3/bag)	3/16"
870032	Thin Medium (3/bag)	3/16"
870041	Thin Soft (24/box)	3/16"
870042	Thin Medium (24/box)	3/16"
870043	Thin Hard (24/box)	3/16"

## Vine Charcoal Canisters

NUMBER	DESCRIPTION
870049	48 bags of #870030 Soft
870050	48 bags of #870032 Med
870051	48 bags of #870031 Hard



Our charcoal is tested in accordance to: ASTM D-4236 and bear safety labels to the standards issued by ACMI.

## Natural Willow Charcoal

Charcoal produced from willow is very soft and produces a deep black favored by many artists. Sticks are cut to 6" in length and vary in width.

NUMBER	DESCRIPTION	WIDTH
870044	Thin Soft (25/box)	1/8"
870045	Medium Soft (25/box)	3/16"
870046	Thick Soft (12/box)	3/16"
870048	Jumbo Soft (4/box)	1/2"
870052	Giant Soft (1/box)	1"
870053	Jumbo Soft (5/box)	1/2"
870047	Assort Soft (30/box)	

## Wooden Box Sets

Richeson offers two types of charcoal in wooden box sets – Natural Willow or Compressed. The Natural Willow Charcoal is produced from willow branches scorched without air access. They feature smooth coverage of a soft-medium grade, which provides easy shading from black to pale grey. Measures 4-3/8" in length and varies in thickness. The Compressed Charcoal is made from a scorched blend of black, wood ground charcoal, gas and Chasov Yar clay. It is a soft-medium grade, producing even coverage.

NUMBER	DESCRIPTION
19101	Set of 50 Natural Willow
19102	Set of 10 Compressed



# BEST ARTIST PRODUCTS

Each BEST Easel is made of American Red Oak, sanded to a smooth surface, then hand-rubbed with oil to reveal the inherent beauty of the wood grain. The craftsmen at BEST nail, glue, and wood screw every joint, ensuring strength and precision. Only the highest quality hardware is used as these easels are built to last a lifetime.

## **BEST Easel Limited Lifetime Warranty**

BEST Artist Easels will repair or replace any part from any BEST Easel or Taboret that proves defective with normal use within the lifetime of the original owner.

## **Replacement of parts under normal wear:**

Wedgelocks, winches and knobs may experience normal wear and require replacement over time. This falls outside the Limited Lifetime Warranty. These parts will be replaced at no charge for one year from purchase date and replaced at reasonable cost plus shipping and handling after one year. Customer is responsible for shipping the part or easel to us as well as return shipping.

Contact customer service at 800-233-2404 for a repair authorization number, prior to shipping. Proof of purchase from a BEST Easel retailer is required. For full warranty details, and to get a repairs, service, parts and warranty claim form, visit our website at [www.richesonart.com](http://www.richesonart.com).

## HOW TO FURNISH YOUR STUDIO

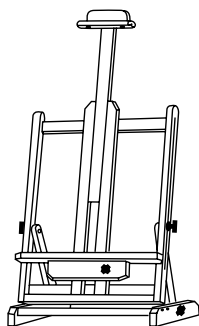
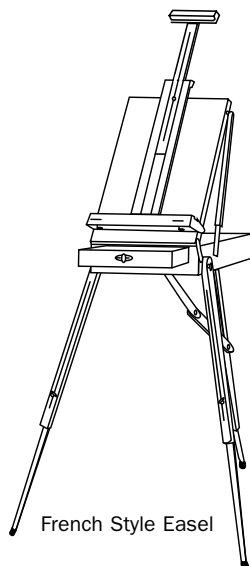
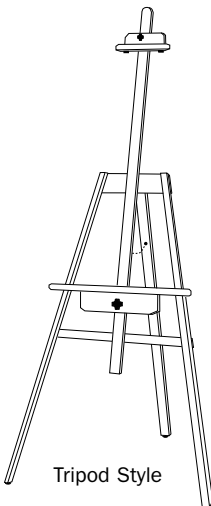

Table Style



French Style Easel



Tripod Style

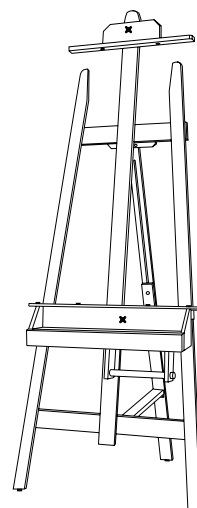

Lyre (A-frame) Style

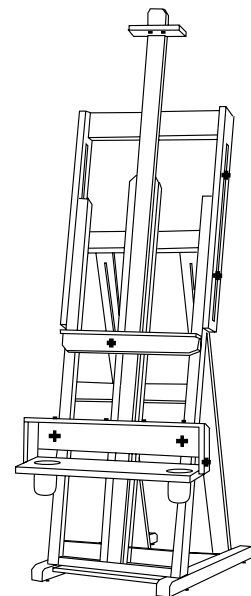

Studio (H-frame) Style

## **Furnishing Your Studio**

The easel is, or can be, the single greatest investment an artist can make. You can purchase a table easel, a modest tripod easel, or go all the way to a deluxe studio easel. Easels are designed in a variety of styles to accommodate many different ways artists work. Be sure you select an easel that works for you!

## **Construction**

The design and construction of your easel are critical to your work. First there is the wood that is used. No question oak is the finest. Because oak is so hard, screws and glue remain secure. Beech on the other hand is so soft that the screws will loosen over time and cause the easel to shake and vibrate. Oak is also one of the most beautiful woods that nature has given us. Many other woods are used from time to time, but oak is, and has been, the preferred wood for easels for several hundred years.

**BEST Easels** are known as some of the finest in the world. Their design, materials and construction set the standard for anyone looking for fine artists' equipment. There is no compromise in workmanship or quality. They are amazingly stable, completely functional and truly beautiful. They are everything artist equipment should be.

## **Styles**

Basically there are only five styles of easels. The Table Easel, the Tripod Easel, the Box or French Style Easel, the Lyre (A-frame) Easel, and the Studio (H-frame) Easel. There are a number of variations to each of these that offer different tilt settings for pastelists or watercolorists, different storage options and size capabilities. Over the years we have increased our selection, and many have features that were added at the request of professional artists.

*BEST designs are an industry gold standard for excellence!*

# BEST ARTIST PRODUCTS

---



EASELS

111

[www.richesonart.com](http://www.richesonart.com)

1.800.233.2404

# BEST ABIQUIU EASELS

*This is the finest piece of artist furniture ever constructed. Built for hard work, this easel was designed by a painter who understood the importance of a solid work station.*

these easels suitable for:  
OIL  
ACRYLIC  
PASTEL

EASELS

112

www.richesonart.com

1.800.233.2404



A. RUBBER CASTERS INCLUDED.

B. RUBBER CASTERS INCLUDED.



# BEST ABIQUIU EASELS

## Abiquiu Easels with a Tab Tray

A beautiful oak tool tray is available for either of the Abiquiu Easels. The tray is 50" wide, 13" deep and 4-1/4" high. The top of the tray is fitted with a melamine surface which can be used for mixing color. This unit can easily be mounted on or removed from the easel. Mounting instructions are included with the easel.

- Tab tray moves smoothly with the use of the heavy-duty pulley system
- Tray features three drawers for supply storage: two measuring 13-3/8" x 10" x 2-1/4", and one measuring 16" x 10" x 2-1/4"
- Box dimensions: 55" x 29" x 6"
- Shipped with easel – add 50 lbs.

### NUMBER DESCRIPTION

- C. 880176 Abiquiu Deluxe with Tray  
D. 880150 Abiquiu with Tray



### A. Abiquiu Deluxe

This easel is constructed of hand rubbed solid oak. By loosening the knobs on the back of the easel, the artist can adjust his or her painting to any tilt or angle. The hardware was designed and made especially for this easel. Up to 300 pounds can be lifted by the heavy-duty marine winch pulley system. Rubber casters make mobility possible.

- Max. canvas height: 120"
- Max. canvas width: 120"
- Base width/depth: 45" x 36"
- Bottom painting tray: 48" x 6"
- Compact easel height: 86"
- Extended easel height: 150"
- Packaged in heavy-duty carton for protection
- Middle canvas holder for smaller work
- Includes front-locking rubber casters
- Shipping weight: 184 lbs.
- Box dimensions: 91" x 54" x 9"
- Ships partially assembled by truck

NUMBER 880175

### B. Abiquiu

A professional, heavy-duty painting easel that offers the same quality features as the Abiquiu Deluxe. This single-masted version has laminated 2" x 5" oak uprights, which provide solid strength.

- Max. canvas height: 120"
- Max. canvas width: 72"
- Base width/depth: 29" x 30"
- Bottom painting tray: 32" x 6"
- Compact easel height: 86"
- Extended easel height: 150"
- Heavy duty marine winch pulley system lifts up to 300 lbs.
- Middle canvas holder for smaller work
- Includes front-locking rubber casters
- Shipping weight: 147 lbs.
- Box dimensions: 92" x 38" x 10"
- Ships partially assembled by truck

NUMBER 880100

Heavy-duty marine style winch easily raises and lowers works weighing up to 300 lbs.

### Abiquiu Melamine Tab Trays

The three drawer tab trays are custom fit to a particular Abiquiu easel. We recommend ordering the tab tray with the easel using the product numbers above. These are for those who already have an Abiquiu and wish to add on. *Trays can be retrofit to easels in the field by the easel owner. Ask for details before ordering.* Dimensions: 50" wide, 13" deep and 4-1/4" high. Shipping weight: 43 lbs.

NUMBER 880005 (tray for Abiquiu)

NUMBER 885006 (tray for Abiquiu Deluxe)



# BEST CLASSIC SANTA FE EASELS

The Classic Santa Fe Easels are excellent for most large work. An artist can work sitting or standing, with a variety of easily adjusted settings and angles. Each features a double laminated quad base, side frames and sturdy H-frame construction. An adjustable extension on the main frame allows added solidity for larger canvases.

this easel suitable for:

- OIL
- ACRYLIC
- PASTEL

EASELS

114

1.800.233.2404 [www.richesart.com](http://www.richesart.com)



B. PLASTIC CASTERS INCLUDED.

# BEST CLASSIC SANTA FE EASELS



A OPTIONAL CASTERS SOLD SEPARATELY.



C OPTIONAL CASTERS SOLD SEPARATELY.

## A. Classic Santa Fe I

This single masted easel comes with two canvas holders and a painting tray. The middle canvas holder can be used for smaller works and the self-leveling bottom tray/palette measures 30" wide by 7-1/2" and features a melamine paint mixing surface with 2 large stainless steel canisters.

- Max. canvas height: 96"
- Base width/depth: 24" x 30"
- Compact easel height: 78"
- Extended easel height: 120"
- Base is drilled for optional casters
- Shipping weight: 75 lbs.
- Box dimensions: 77" x 30" x 10"
- Ships partially assembled by truck

NUMBER 880300 

## B. Classic Santa Fe II (opposite page)

This easel offers the same quality features as the Classic Santa Fe I with a few extras. Its marine style winch raises and lowers easily allowing works weighing up to 300 lbs. The double-masted H-frame offers extra stability and will hold larger canvases than the Santa Fe I & III. Plastic front locking casters offer mobility.

- Max. canvas height: 106"
- Base width/depth: 24" x 30"
- Compact easel height: 78"
- Extended easel height: 129"
- Includes plastic casters
- Shipping weight: 98 lbs.
- Box dimensions: 77" x 30" x 10"
- Ships partially assembled by truck

NUMBER 880350 

## C. Classic Santa Fe III

~~An artist asked for the Santa Fe I with the pulley system of the Santa Fe II. Specifications can be found listed under the Santa Fe I.~~

- ~~Shipping weight: 86 lbs.;~~
- ~~ships partially assembled by truck~~

NUMBER 880202 



# BEST KELLEY CRANK AND CRANK EASELS



## A. Kelley Crank Dark Easel

Although designed for the portrait painter, it is a valuable tool for any painter. This easel will slant forward or backward. Its height is adjustable by the simple turn of a crank that is secured to a pulley system.

- Maximum canvas height: 84"
- Base width/depth: 29" x 30"
- Compact easel height: 70"
- Extended easel height: 104"
- Middle canvas holder for small work
- Includes front-locking plastic casters
- Shipping weight: 101 lbs.
- Box dimensions: 78" x 40" x 10"
- Ships partially assembled by truck

NUMBER 882471 

## B. The Crank Easel

The oak construction and heavy-duty crank system will allow even your largest canvases to glide up and down with quiet ease. Note: The mast will lift as the lower canvas tray is lifted, so consider ceiling height.

- Maximum canvas height: 66"
- Base width/depth: 29-3/4" x 30"
- Compact easel height: 92"
- Extended easel height: 127"
- Middle canvas holder for small work
- Includes front-locking plastic casters
- Shipping weight: 96 lbs.
- Box dimensions: 92" x 53" x 10"
- Ships partially assembled by truck

NUMBER 880151 

# BEST ELEGANT H AND MANHATTAN EASELS



A OPTIONAL CASTERS SOLD SEPARATELY.



B RUBBER CASTERS INCLUDED.

## A. Elegant H-Frame

This oak easel features a winch and pulley system that allows the canvas to be raised and lowered with ease. It includes two stainless steel cups and a storage drawer to hold a variety of supplies.

- Maximum canvas height: 82"
- Base width/depth: 24" x 24"
- Maximum easel height: 129"
- Minimum easel height: 63"
- Bottom canvas tray width: 28"
- Top canvas tray width: 24"
- Angled storage drawer: 17-34" wide x 4-1/4" deep
- Base is drilled for optional casters
- Shipping weight: 83 lbs.
- Box dimensions: 78" x 30" x 10"
- Ships by truck

NUMBER 880065 

## B. Full-Tilt Manhattan

Designed by a portrait painter, the Manhattan's top carriage is designed to tilt forward and backward, and slide up and down. It features a double fold-out painting tray with a melamine paint-mixing surface and two large stainless steel canisters for solvents. Closed, the tray is 30" wide, open it is 60" wide.

- Max. canvas height: 88" with tray; 102" with tray removed
- Base width/depth: 27" x 30"
- Compact easel height: 75"
- Extended easel height: 118"
- Adjustable sliding mast moves independently of the tray
- Middle canvas holder for small work
- Includes front-locking rubber casters
- Shipping weight: 93 lbs.
- Box dimensions: 92" x 29" x 10"
- Ships partially assembled by truck

NUMBER 887120 

## C. Rubber Casters

Heavy-duty rubber casters make moving and locking into place effortless. May be ordered separately for easels with a quad base. Each package contains 4 casters – 2 locking, 2 non-locking.

NUMBER 880003 (Pack of 4)

## D. Plastic Casters

NUMBER 880004  
(Pack of 4 – 2 locking, 2 non-locking)

NUMBER 880009  
(Locking, sold individually)

NUMBER 880008  
(Non-locking, sold individually)



# BEST DULCE & SAN PEDRO EASELS



A OPTIONAL CASTERS SOLD SEPARATELY.

## A. Classic Dulce

This is a standard American studio easel designed to provide the artist with the most stable unit at a low price. Its sturdy H-frame construction and laminated quad base offer superior strength and stability. It adjusts easily to a variety of custom settings for working seated or standing.

- Maximum canvas height: 82"
- Base width/depth: 22" x 24"
- Compact easel height: 54"
- Extended easel height: 90"
- Folds flat for easy storage
- Adjustable sliding mast moves independent of canvas tray
- Wide bottom canvas holder with utility tray
- Base is pre-drilled for optional casters
- Shipping weight: 37 lbs.
- Box dimensions: 55" x 29" x 6" oversized
- Ships partially assembled by UPS

NUMBER 880200



B OPTIONAL CASTERS SOLD SEPARATELY.

## B. Giant Dulce

Artists demanded a studio easel just like the BEST Classic Dulce, that could handle a wider canvas without doubling the cost. This easel is constructed with a wider H-frame that allows it to accommodate wider paintings.

- Maximum canvas height: 82"
- Base width/depth: 25-3/4" x 30"
- Compact easel height: 69"
- Extended easel height: 105"
- Folds flat for easy storage
- Adjustable sliding mast moves independent of canvas tray
- 30" wide bottom canvas holder with utility tray
- Base is pre-drilled for optional casters
- Shipping weight: 54 lbs.
- Box dimensions: 78" x 30" x 10"
- Ships partially assembled by truck

NUMBER 880201 



C

## C. San Pedro

The easel for small, medium and large works in oil, acrylic, and pastel. Versatile and strong, the San Pedro offers a multitude of height and tilt settings.

- Maximum canvas height: 82"
- Base width/depth: 35" x 27"
- Compact easel height: 63"
- Extended easel height: 102"
- Adjustable sliding mast moves independent of canvas tray
- Wide painting tray features 30" x 4-1/4" work surface & rubber cleats to secure canvas
- Tilts forward for pastel artists (use weights on back legs when used in this position)
- Bottom shelf for storage
- Cannot accommodate casters
- Shipping weight: 72 lbs.
- Box dimensions: 68" x 39" x 9"
- Ships partially assembled by truck

NUMBER 886004 

# BEST A-BEST & B-BEST EASELS

This series was the start of BEST Artist's Products. These great easels revolutionized artist easels when they hit the market. Copied by almost every easel manufacturer in the market, no one has yet mastered the quality and perfection of BEST. Note: these easels cannot accommodate casters.



A



B



C



D

## A-Best & B-Best

These are moderately priced easels for the oil and acrylic painter. The sturdy tri-mast A-frame design is lightweight, portable, durable and folds flat for easy storage. Both feature non-skid rubber feet for stability.

### A. A-Best

- Can hold canvases up to 64" high
- Base width/depth: 28" x 28"
- Extended easel height: 81"
- Shipping weight: 26 lbs. - OS
- Box dimensions: 74" x 7" x 7"
- Ships by UPS, assembly required

**NUMBER 882100**

### B. B-Best

- Can hold canvases up to 52" high
- Base width/depth: 28" x 28"
- Extended easel height: 68"
- Shipping weight: 25 lbs. - OS
- Box dimensions: 75" x 7" x 7"
- Ships by UPS, assembly required

**NUMBER 882200**

### C. Lite B-Best

- Maximum canvas height: 60"
- Base width/depth: 26" x 26"
- Extended height: 80"
- Sturdy A-frame design
- Folds flat for easy storage
- Shipping weight: 20 lbs.
- Box dimensions: 55" x 29" x 6" - OS
- Ships assembled by UPS

**NUMBER 882225**

### D. B-Best Adjustable

- Maximum Canvas Height: 75"
- Base: width/depth 22" x 24"
- Extended Height: 96"
- Compact Height: 65"
- Sturdy A-Frame design
- Wider Adjustable Mast
- Box dimensions: 62" x 29" x 7" - OS
- Shipping weight: 29 lbs.
- Ships assembled by UPS

**NUMBER 882210**

# BEST UNIVERSITY AND WALLMOUNT EASELS



A OPTIONAL CASTERS SOLD SEPARATELY.



B

## A. University Easel

This easel offers a wide range of tilt adjustments including a forward tilt of nearly 60 degrees to allow pastel dust to fall from the surface or to reduce glare. The easel was designed to shift the weight to the rear when the easel is leaning forward giving the easel the necessary stability required for this position.

- Maximum canvas height: 84"
- Base width/depth: 22-1/2" x 30"
- Minimum easel height: 73"
- Maximum easel height: is 110"
- Deluxe 30" wide painting tray features tool shelf and two stainless steel cups
- Middle painting tray for small work
- Hinges at joints for strength
- Double laminated base for extra strength
- Base is pre-drilled for optional casters
- Shipping weight: 65 lbs.
- Box dimensions: 77" x 30" x 10"
- Ships partially assembled by truck

NUMBER 880400 

## B. Wallmount Easel

BEST's Wallmount is the ideal solution for the artist with limited studio space. BEST understands that many professional artists must achieve a balance between space concerns and workability. The Wallmount achieves both goals, a heavy-duty easel that accommodates a large canvas with zero use of studio floor space. A sturdy oak easel that was designed to be mounted on the wall. The easel can be used in a vertical position or tilted forward. Perfect for the studio with limited floor space.

- Maximum canvas height: 88"
- Width/depth: 32" x 14" (without tilt)
- Compact easel height: 59"
- Extended easel height: 102"
- Forward tilt (up to 80° angle) for glare reduction or for pastel artists
- Smooth, easy height adjustability
- Shipping weight: Box 1: 42 lbs.; Box 2: 19 lbs.
- Box dimensions: Box 1: 55" x 29" x 8" ; Box 2: 35" x 12" x 10"
- Ships partially assembled by UPS

NUMBER 887100



# BEST DELUXE LOBO EASEL



## ***The Most Copied Easel in the World!***

*We even copied our own design to compete with the pirates of the world. See page 142 for our Richeson Lyptus® Wood version of the popular Deluxe Lobo.*

### **Deluxe Lobo**

Built of solid oak, this quad base easel is perfect for the mixed media painter. It is inexpensive, compact but sturdy, reliable and very flexible. Can be used vertically for sketching or painting, and in just seconds can be adjusted to a horizontal position for watercolor, gessoing or varnishing. Plus, the Deluxe Lobo features a built in shelf for supplies or books.

- Maximum canvas height: 62"
- Base width/depth: 24" x 27"
- Compact easel height: 65"
- Extended easel height: 92"
- Table height: 36"
- Adjusts quickly to a variety of settings for sitting or standing
- Forward tilt for glare reduction or for the pastel artist
- Shipping weight: 35 lbs.
- Box dimensions: 55" x 29" x 6"
- Ships partially assembled by UPS

**NUMBER 883200**



# BEST MANZANO & HALLEY EASELS

Special features on each of these BEST easels make them a unique and special find! From working horizontally as a watercolor artist to needing a forward tilt as a pastel artist, these easels offer the quality construction you find **only** in a BEST easel by Jack Richeson & Company! Note: Easels on this page do not accommodate casters.



## A. **Manzano**

The Manzano features a unique frame design which slides down and locks for seated work; tilts horizontally for watercolor or varnishing; or raises vertically and locks into a higher position for standing work.

- Maximum canvas height: 50"
- Base width/depth: 26" x 22"
- Compact easel height: 42"
- Horizontal easel height: 35"
- Adjustable 20" wide painting tray
- Rubber grips on trays to keep canvas secure
- Strong quad base
- Rubber no-slip tips on base for stability
- Shipping weight: 25 lbs. - oversize
- Box dimensions: 55" x 29" x 6"
- Ships partially assembled by UPS

**NUMBER 883350**

## B. **Halley**

Beautiful and strong, the Halley will tilt into a table for gessoing, varnishing or watercolor work. It will tilt forward for pastel artists to allow the pastel dust to fall from the work surface. The Halley also has a multitude of settings for use with oil, acrylic, or airbrush.

- Maximum canvas height: 80" vertical; 82" horizontal
- Base width/depth: 23" x 27"
- Compact easel height: 54"
- Maximum easel height: 84"
- Height when used as a table: 36"
- Self leveling tray features a melamine paint mixing surface with a small stainless steel cup for solvent.
- Painting trays have rubber grips to keep canvas secure
- Shipping weight: 52 lbs.
- Box dimensions: 55" x 29" x 8"
- Ships partially assembled by UPS

**NUMBER 880600**

# BEST EUROPEAN AND PORTABLE COLLAPSIBLE EASELS



## A. European Easel

Quickly adjustable, the European easel accommodates a wide range of media, from watercolor, acrylic, oil, airbrushing and pastels, offering a versatility that enables it to adjust to your changing needs.

- Maximum canvas height: 84"
- Base width/depth: 22" x 30"
- Compact easel height: 80"
- Extended easel height: 120"
- Horizontal easel height: 29-1/2"
- 30" wide painting tray with 2 stainless steel cups
- A 20-1/2" x 5" well for supplies
- Middle painting tray for small work
- Hinges at joints for strength
- Base drilled for optional casters
- Shipping weight: 76 lbs.
- Box dimensions: 77" x 30" x 10"
- Ships partially assembled by truck 

NUMBER 880525

## B. Portable Collapsible Easel

This all-purpose easel is ideal for the oil, watercolor, pastel, airbrush or acrylic artist. Whether sitting or standing, a full range of angles (from vertical to horizontal) is possible. The front wheels offer mobility.

- Maximum canvas height: 72"
- Base width/depth: 17" x 17"
- Compact easel height: 50"
- Extended easel height: 90"
- Folds flat for storage
- Painting trays have rubber grips to keep canvas secure
- Table height: 37-3/4"
- Bottom shelf for storage
- Shipping weight: 35 lbs.
- Box dimensions: 55" x 29" x 6"
- Ships partially assembled by UPS

NUMBER 887110

# BEST RIO GRANDE AND NAVAJO EASELS

Beautiful, lightweight, and easy-to-manage, the Rio Grande and Navajo are great USA made BEST Easels for the painter with limited space, the dorm room painter or the beginning artist. Made in the BEST tradition of quality with great attention to detail and workmanship, these easels carry the BEST Limited Lifetime Warranty. (For details, see page 110.)



Great beginner easels or for those with limited space!

## A. ~~Rio Grande~~

~~A great starter easel. This multi-functional easel has a strong quad base and was designed for easy adjusting. It will extend upwards to handle a 48" canvas, yet compact down to only 45".~~

- ~~• Base width/depth: 25" x 23"~~
- ~~• Extended easel height: 72" high~~
- ~~• Adjusts quickly to a variety of settings for sitting or standing~~
- ~~• Includes a middle canvas tray for small work~~
- ~~• All canvas holders have rubber grips to keep canvas secure~~
- ~~• Shipping weight: 27 lbs.~~
- ~~• Box dimensions: 56" x 29" x 8"~~
- ~~• Ships assembled by UPS~~

**NUMBER 883325**

## B. ~~Navajo~~

~~A great starter easel. Inexpensive, compact but sturdy and reliable. Perfect for the college dorm. Folds flat for easy storage.~~

- ~~• Will hold canvases up to 38" high~~
- ~~• Base width/depth: 26" x 26"~~
- ~~• Maximum height: 60"~~
- ~~• Adjusts quickly to a variety of settings for sitting or standing~~
- ~~• Top & bottom canvas holders have rubber grips to keep canvas secure~~
- ~~• Shipping weight: 11 lbs.~~
- ~~• Box dimensions: 46" x 27" x 4"~~
- ~~• Ships by UPS, some assembly required~~

**NUMBER 885300**

# BEST CHIMAYO EASELS

Strength and beauty in three sizes. The Chimayo's have an elegant single mast design that is supported by a double laminated quad base on the Chimayo, and by a T-frame construction on the Medium and Student Chimayo. Simple adjustments allow the artist to custom set the easel for each canvas.



## A. Chimayo

- Maximum canvas height: 72"
- Canvas holders have rubber grips to keep canvas secure
- Base width/depth: 26" x 30"
- Compact easel height: 85"
- Extended easel height: 87"
- Bottom canvas holder includes utility shelf
- Folds flat for easy storage
- Front locking casters are optional
- Base is pre-drilled for optional casters
- Shipping weight: 35 lbs.
- Box dimensions: 87" x 7" x 7"
- Ships by UPS, assembly required

**NUMBER 882350**

## B. Medium Collapsible Chimayo

- Maximum canvas height: 66"
- Rubber grips on canvas holders
- Base width/depth: 26" x 26"
- Compact easel height: 52"
- Extended easel height: 82"
- Folds flat for easy storage
- Bottom canvas holder includes utility shelf
- Shipping weight: 28 lbs.
- Box dimensions: 55" x 29" x 5"
- Ships partially assembled by UPS

**NUMBER 882325**

## C. Student Chimayo

- Maximum canvas height: 64"
- Base width/depth: 26" x 24"
- Compact easel height: 51"
- Extended easel height: 82"
- Folds flat for easy storage
- Rubber grips on canvas holders
- Ideal display easel
- Shipping weight: 21 lbs.
- Box dimensions: 55" x 29" x 6"
- Ships partially assembled by UPS

**NUMBER 882300**

# BEST *natural* EASELS

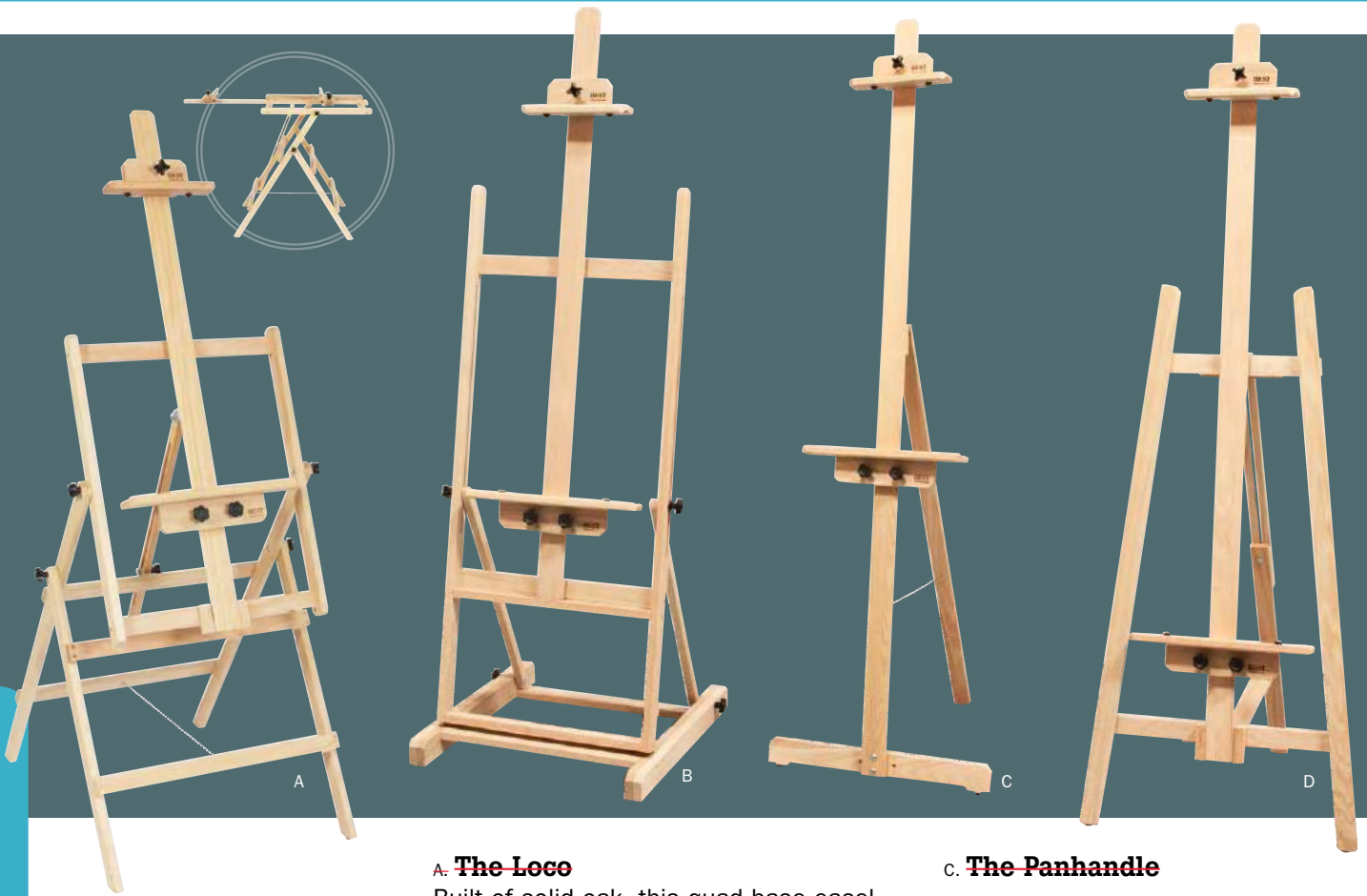

Over the years, we have been asked if BEST could produce a "skinnied-down" version of some of our most popular BEST Traditional Oak Easels.

**We proudly introduce our USA Made BEST Natural Easels.**

- Unstained American Oak
- Lighter weight than their traditional BEST counterparts
- Limited Lifetime Warranty

**Compete against imported easels with these easels Made in the USA!**

## A. **The Loco**

~~Built of solid oak, this quad base easel is compact, sturdy and very flexible. Can be used vertically or horizontally.~~

- ~~• Maximum canvas height: 38"~~
- ~~• Base width/depth: 24" x 30"~~
- ~~• Extended easel height: 65"~~
- ~~• Table height: 33"~~
- ~~• Adjusts to a variety of settings for sitting or standing~~
- ~~• Forward tilt for glare reduction or for the pastel artist~~
- ~~• Shipping weight: 19 lbs.~~
- ~~• Box dimensions: 72" x 26" x 5"~~
- ~~• Ships fully assembled by UPS~~

**NUMBER 882420**

## B. **The Frontier H-Frame**

With a sturdy H-frame construction and quad base for strength and stability, this easel adjusts easily to a variety of settings for working seated or standing.

- Maximum canvas height: 46"
- Base width/depth: 22" x 24"
- Easel height: 67"
- Folds flat for easy storage
- Shipping weight: 23 lbs.
- Box dimensions: 72" x 26" x 5"
- Ships fully assembled by UPS

**NUMBER 882410**

## C. **The Panhandle**

- ~~• Maximum canvas height: 63"~~
- ~~• Base width/depth: 22" x 24"~~
- ~~• Easel height: 72"~~
- ~~• Folds flat for easy storage and transport~~
- ~~• Rubber grips on canvas holders~~
- ~~• Ideal display easel~~
- ~~• Shipping weight: 10 lbs.~~
- ~~• Box dimensions: 75" x 5" x 5"~~
- ~~• Ships mostly assembled by UPS~~

**NUMBER 882430**

## D. **The Autry A-Frame**

The sturdy tri-mast A-frame design is lightweight, portable, durable and folds flat for easy storage.

- Maximum canvas height: 54"
- Base width/depth: 25" x 24"
- Extended easel height: 71"
- Shipping weight: 15 lbs.
- Box dimensions: 72" x 26" x 5"
- Ships fully assembled by UPS

**NUMBER 882400**

# BEST ARTIST ORGANIZER



This studio organizer has a never-ending list of what they can be used for: pastels, brushes and paints just to name a few. They work great in the classroom for storing student projects on the shelves. They are beautiful and practical! The artist organizers are a convenient way to store a variety of artist tools.

Each removable shelf allows for simple transport of supplies to your work area.

*Simply take the shelf out and go!*

## Large Artist Organizer

- Display dimensions: 18"(w) x 35-1/8"(d) x 65-1/2"(h)
- Flat dimensions: 18"(w) x 5-1/4"(d) x 67-1/2"(h)
- Shelf dimensions:  
5 small shelves 17" x 9-3/4" 2 large shelves 17" x 12-3/4"
- Shipping weight: 28 lbs.
- Box dimensions: 71" x 14" x 3"
- Ships partially assembled by UPS

**NUMBER 887136**



# ~~BEST BOUNDARY-FREE EASEL~~

## ~~The B.F.E.~~

~~Boundary Free  
Easel System  
by BEST~~

*Build the  
configuration  
that works  
for you!*

**~~Finally!~~**  
~~An easel that  
can accommodate  
pieces virtually any  
width or height.~~

If you are working in  
a room high enough  
or wide enough, the  
BFE components can  
be built to hold your  
painting!

**~~Also perfect for:~~**

- ~~— Galleries~~
- ~~— Schools~~
- ~~— Display~~

Pushing your creativity  
beyond the boundaries!





# ~~BEST BOUNDARY-FREE EASEL~~

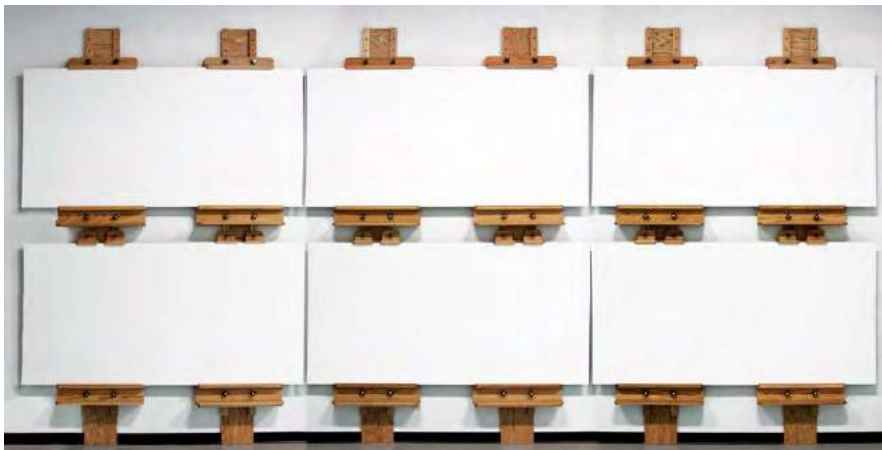

Perfect for school and workshop use  
or for artists who prefer to work  
on more than one piece at a time!



EASELS

129

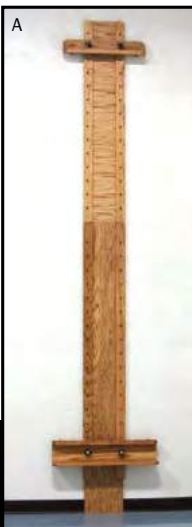

- A. Wall Mast (3 ft. #887303, 5 ft. #887305, 7 ft. #887307)  
(holders and trays not included)
- B. Convertible Easel with 4 Trays (Item #887326)
- C. ~~30" Large Bottom Canvas Tray (Item #887320)~~
- D. ~~24" Large Top Canvas Holder (Item #887322)~~  
or ~~Small Bottom Canvas Tray (Item #887321)~~
- E. ~~8" Small Top Canvas Holder (Item #887323)~~
- F. Copper Posts 4 pack (Item #887324)
- G. Canvas Hanger 8 pack (Item #887325)



Call for complete kits and custom studio  
set-ups. 920.738.0744

# BEST TABOSETS

BEST taboret designs give the artist a premium piece of equipment. Made of solid oak and oak panel (no particle board is used), the units are finished on all four sides so that they can be used either in the center of the room or against the wall. Open the wings or drawers and discover an extra large work space that is designed to work well with different mediums. Take a good look at your working style and pick the taboret that works best for you. Units with wings have extra support with two fold-out arms that give them that extra BEST touch.

Beautiful taboret built for maximum versatility!

EASELS



RUBBER CASTERS INCLUDED.



## Kate Palmer Taboret

Built from solid oak for strength and aesthetics, the Kate Palmer Taboret is mounted on front locking casters for mobility. What makes this taboret so unique is the flexibility it offers. The top work surface can slide forward so the artist can sit at it like a desk, or it can slide backward to create an extra flat work area. And the top work area can be assembled so that either side of the taboret can be the "front". The bottom drawers are accessible from either side of the taboret, and there are two generous "cubbies" on one side for storage. The top work area features a melamine surface with a plexiglass insert for easy clean up. There are also holes for a water canister, cups and brushes.

- Base width/depth: 50" x 28"
- Working height: 35"
- Central melamine work surface: 27"(w) x 20"(d)
- Top storage area: 48 1/2"(w) x 6 1/4"(d)
- 3 top drawers inner: 45"(w) x 17 1/2"(d) x 2"(h)
- 5 bottom drawers inner dimensions: 46"(w) x 26"(d) x 2 1/2"(h)
- 2 back storage areas: 47"(w) x 7 1/2"(d) 6 1/4"(h) & 47"(w) x 8"(d) x 7 1/4"(h)
- Includes front locking rubber casters.
- Shipping weight: 560 lbs.
- Ships by truck, minimal assembly required
- Lift gate required
- Box dimensions: 56" x 30" x 45"

NUMBER 880025 

# BEST TABOURETS



## A. **Urania's Desk**

Ideal for pastel painting. Originally designed for world-famous pastelist Urania Christy Tarbet, this desk is the answer for the pastel painter who seeks convenience and organization. What looks like an unobtrusive hutch or TV console when not in use, blooms like a lotus into a variety of pastel storage trays and much needed workspace and storage area. Designed for the pastelist, but perfect for the oil painter or watercolorist as well.

- Closed height: 32-1/2"; Depth: 23"  
Closed width: 36"
- Includes attached easel
- Features 26" x 18" x 1-1/2" pivoting drawers hold a variety of pastel sticks or paint tubes
- Doors open to support weight of swinging drawers
- 2 large stainless steel canisters are included with space available for an additional 2 canisters
- The easel is mounted to the back of the desk and will slide out-of-sight for storage
- Maximum canvas height: 36"
- Easel will adjust from flat to a forward tilt
- Packaged in heavy duty carton
- Shipping weight: 140 lbs.
- Box dimensions: 25" x 40" x 34"
- Ships assembled by truck

**NUMBER 880017** 



B

**RUBBER CASTERS INCLUDED.**

## B. **Shawn's Watercolor Station**

Ideal for flat work

- Height: 33"; Depth: 22-1/2";  
Closed width: 41-3/4";
- Ideal for varnishing, gessoing or watercolor work
- Mounted on front locking rubber casters for mobility
- Offers 5 supply drawers of various depths for a variety of supplies
- Top surface and drawers are on smooth, full extension, metal bearing sliders for easy opening
- Open the top for additional work space and storage area. Includes 1 large stainless steel canister
- Front side doors open on brass piano hinges: right side offers 9-3/4" (w) x 25-3/4" (h) x 19" (d) storage area and left side offers two 19" deep utility shelves
- Packaged in heavy-duty carton
- Shipping weight: 200 lbs.
- Box dimensions: 44" x 32" x 24"
- Ships assembled by truck. (Casters and handles must be attached when unit arrives to prevent damage in shipping.)

**NUMBER 880018** 

# BEST TABOSETS

The Deluxe Table Top Easel is a great addition to the Terrero Taboret!  
(Terrero does not come with the Deluxe Table Top.)



EASELS

132

www.richesart.com

1.800.233.2404

RUBBER CASTERS INCLUDED.

## A. Terrero

Treat yourself to a tool that will make you want to work, like this gorgeous taboret that offers storage space to keep you organized, work space to spread out on and the ability to become a complete work station with the addition of the **Deluxe Table Top Easel, sold separately.**

- Height: 32-1/4"; Width: 22-1/4"; Depth: 22"
- Offers a 4" high outer supply drawer, a 3-1/2" inner drawer, a slide-out shelf & storage space
- 1-1/8" slots for secure mounting of optional table easel
- Opened, the unit offers a 20" x 40" work space with 2 large canisters off to one side
- When the Deluxe Table Top Easel is in a horizontal position, it can be used for varnishing, gessoing or watercolor work
- Mounted on front-locking rubber casters for mobility
- Packaged in heavy duty carton for protection
- Shipping weight: 78 lbs.  
Box dimensions: 23" x 23" x 35"
- Ships assembled by truck.  
(Casters must be attached when unit arrives to prevent damage in shipping.)

NUMBER 886003 

## B. Deluxe Table Top

This heavy-duty professional table easel can be used by itself on any flat surface, or with the Terrero Taboret unit seen above. Either way, this is a sturdy piece of equipment with both form and function.

- Holds canvases up to 36"
- Base width/depth: 18" x 18"
- Extended height: 47"
- Expandable mast with movable canvas holders
- Can be used horizontally
- Folds easily for storage
- A great addition to the Terrero Taboret (above) #886003
- Shipping weight: 14 lbs.
- Box dimensions: 31" x 21" x 6"
- Ships assembled by UPS

NUMBER 884200

# BEST TABORETS

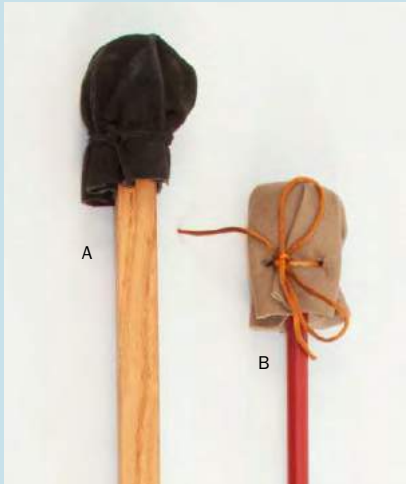

## Mahl Sticks

A wonderful arm rest, the mahl stick is used to relieve pain in shoulders, arms and hands which is common from years of painting.

### A. Solid Oak

- Length: 40"
- Width: 5/8" x 5/8"
- Includes soft cloth cover
- Made of solid oak
- Shipping weight: 3 lbs.

**NUMBER 880181**

### B. Metal & Cork

- A two piece lightweight, varnished, aluminum rod with cork ball.
- Includes soft cloth cover.

**NUMBER 696024**

## Stainless Steel Canisters

### Large Canister

5" wide and 5-3/4" high.

**NUMBER 895001**

### Small Cup

2-1/4" wide, 1-3/4" high.

**NUMBER 895010**



See page 162 for brush cleaning screens to fit right inside of your stainless steel canisters!



## The Sitha Taboret

Ideal for pastel, oil and water media.

- Closed width/depth: 2-1/4" x 26"
- Closed height: 37";
- Extended height: 87"
- Extended width: 48"
- Max. canvas height: 44"-54" (Has peg locking device in 2nd drawer to extend canvas height to 54".)
- Attached fold-out easel can be adjusted to forward tilt
- Drawers are on smooth, full extension, metal bearing sliders for easy opening
- Top drawer contains a 1/4" thick, 18" square melamine palette and a fold out holder for the supplied brush washer #411250 (see page 166 for image of brush washer.)



Unit when closed.

- Third drawer is deep enough for storage of canvas trays from easel when unit is closed
- Mounted on front locking rubber casters
- Packaged in heavy duty carton
- Shipping weight: 150 lbs.
- Box dimensions: 27" x 27" x 34"
- Ships assembled by truck. (Casters must be attached when unit arrives to prevent damage in shipping.)

**NUMBER 880019** 

# BEST TABORETS

## A. **Becky Taboret**

Great for home or studio! Easel lays flat for storage and wings fold over offering a flat work space suitable for full sheets of watercolor paper or other projects. Lower shelf area is great for storing supplies.

- ~~Taboret height (closed): 32"~~
- ~~Taboret depth (closed): 24"~~
- ~~Includes attached easel~~
- ~~Maximum easel height: 75 1/2"~~
- ~~Minimum easel height: 58"~~
- ~~Maximum width: 80" (wings open)  
40" (wings closed)~~
- ~~Maximum canvas height: 39"~~
- ~~Adjustable double mast~~
- ~~Forward tilt for pastels~~
- ~~2 Small storage compartments:  
4 1/2" x 21"~~
- ~~Lower storage shelf: 19" x 38"~~
- ~~Does not accommodate casters~~
- ~~Assembly required~~
- ~~Shipping weight: 94 lbs.~~
- ~~Box dimensions: 55" x 30" x 9"~~
- ~~Ships by truck~~

**NUMBER 880061** 



Shown with easel stored in unit.

*Versatile taborets for working in  
pastel, oil, acrylic, AND watercolor!*

## B. **Caitlin Taboret**

This oak taboret is useful for any artist whether they work in pastel, water media or oils. The attached easel can be positioned to any angle and varying heights to accommodate a variety of working positions. It includes a large stainless steel brush washer and a stainless steel canister, and features locking rubber casters for mobility.

- Base width/depth: 32" x 21-1/2"
- Unit width with wings extended: 64"
- Includes attached easel
- Maximum easel height: 68-1/2"
- Taboret height: 30"
- Maximum canvas height: 33"
- Pull-out work surface:  
26" (w) x 18"(d)
- Drawer inside dimensions:  
26-3/4"(w) x 17-1/2"(d) x 3-1/2"(h)
- Cabinet inside dimensions:  
30-1/4"(w) x 19-3/4"(d) x 16"(h)
- Includes rubber casters
- Shipping weight: 138 lbs.
- Box dimensions: 35" x 25" x 35"
- Ships by truck

**NUMBER 880060** 



Shown with easel stored.

**RUBBER CASTERS INCLUDED.**

# BEST TABORETS

These taborets, made in the BEST tradition of form and function conceal and store beautifully! These are a great addition to any artist's studio and can even be a useful tool in the classroom. The units are mounted on locking casters, making mobility a breeze! The BEST Limited Lifetime Warranty makes these a must-have.

## A. Best Studio Taboret 5 Drawer with Cubby

- Taboret dimensions:  
30"(w) x 19-1/2"(d) x 30-1/4"(h)
- Top 3 drawer dimensions (inside):  
14-3/4"(w) x 16-1/2" (d) x 1-3/4"(h)
- 4th drawer dimensions (inside):  
14-3/4"(w) x 16-1/2" (d) x 6-1/4"(h)
- 5th drawer dimensions (inside):  
14-3/4"(w) x 16-1/2" (d) x 9"(h)
- Side Compartment  
10"(w) x 17-3/4" (d) x 24-1/2"(h)
- Includes plastic casters
- Shipping weight: 93 lbs.
- Box dimensions: 34" x 24" x 30"
- Ships UPS

NUMBER 880077

## B. Best Studio Taboret

- Taboret dimensions:  
19-1/2"(w) x 20-1/4"(d) x 30-1/4"(h)
- Drawer dimensions (inside):  
14-3/4"(w) x 16-1/2"(d) x 1-3/4"(h)
- Bottom compartment:  
16-3/4"(w) x 17-3/4"(d) x 16-1/2"(h)
- Adjustable shelf included
- Made of solid oak/oak plywood
- Includes plastic casters
- Shipping weight: 53 lbs.
- Box dimensions: 23" x 23" x 35"
- Ships UPS

NUMBER 880075

## C. Best Studio Taboret 5 Drawer

- Taboret dimensions:  
19-1/2"(w) x 19-1/2"(d) x 30-1/4"(h)
- Top 3 drawer dimensions (inside):  
14-3/4"(w) x 16-1/2" (d) x 1-3/4"(h)
- 4th drawer dimensions (inside):  
14-3/4"(w) x 16-1/2" (d) x 6-1/4"(h)
- 5th drawer dimensions (inside):  
14-3/4"(w) x 16-1/2" (d) x 9"(h)
- Made of solid oak and oak plywood
- Includes plastic casters
- Shipping weight: 66 lbs.
- Box dimensions: 23" x 23" x 35"
- Ships UPS

NUMBER 880076



PLASTIC CASTERS INCLUDED.



PLASTIC CASTERS INCLUDED.

# BEST TABOURETS

## A. Oak Flat File

Designed to ship unassembled to save on shipping costs and lower the chance of damage during shipping, this flat file assembles into a sturdy piece of furniture. Each of the drawers are large enough to hold full sheets of artists' paper. Drawer dimensions: 40-1/2"(w) x 28"(l) x 3"(d). Mix and match pieces for a customized storage space! 🚚

*Base and cap must be purchased separately for each drawer section purchased. Packages include cap and base.*

NUMBER	DESCRIPTION
880116	3 Drawer Package
880117	5 Drawer Package
880118	10 Drawer Package
880119	15 Drawer Package
880120	8 Drawer Package
880121	Base and Cap
880122	3 Drawer Section*
880123	5 Drawer Section*

\*Requires a base and cap

## Oak Flat File Assembly

For a nominal fee, let us take care of the assembly and we will ship the assembled unit to you! **NUMBER 880124**



A

## B. BEST Art Cart

Not many art instructors have the luxury of having their own classroom. Our mobile art station helps these special educators stay organized! Made of oak in the BEST tradition of quality, this cart will withstand the mobility necessary for a traveling classroom! When open, this unit is a workable station, when closed it appears to be a high quality cabinet that would enhance any room at school or home. This station includes a magnetic latch, brass piano hinges on the doors, two shelves, a sliding drawer and rolling casters.

- Base width/depth: 36" x 24"
- Cart height: 41-1/4"
- Drawer dimensions: 33-1/4" x 21-1/4" x 3-1/4"
- Includes rubber casters
- Shipping weight: 146 lbs.
- Box dimensions: 39" x 29" x 42"
- Ships assembled by truck

**NUMBER 886017** 🚚



B

**RUBBER CASTERS INCLUDED.**



*The BEST Art Cart closes securely, keeping supplies hidden and making transport a breeze!*



# BEST MODULAR WORK STATION



## BEST Work Station

Create your own work station! Mix and match these sturdy raw oak and birch pieces to meet any artists needs. Integrate the table top section (#3) with any two side pieces to create a work station suited just for you!

### A. Small Shelf Unit

#### PART 1

37"(h) x 34"(w) x 9-1/2"(d)

Shipping information:

134lbs.; 39" x 36" x 13"

NUMBER 880081

### B. Large Shelf Unit

#### PART 2

37"(h) x 34"(w) x 19"(d)

Shipping information:

105lbs.; 23" x 37" x 40"

NUMBER 880082

### C. Table Top

#### PART 3

Includes a towel holder and 4 large stainless steel canisters.

1-1/2" thick x 61-1/2"(w) x 36"(d)

Shipping information:

50lbs.; 63" x 37" x 5"

NUMBER 880083

### D. Paper Slots

#### PART 4

37"(h) x 34"(w) x 19"(d)

Shipping information:

87lbs.; 36" x 22" x 39"

NUMBER 880084

### E. Drawer

#### PART 5

3-1/2"(h) x 15-1/4"(w) x 25-3/8"(d)

Shipping information:

11lbs.; 31" x 21" x 6"

NUMBER 880085

### F. Small Extra Shelf

#### PART 6

37"(h) x 34"(w) x 9-1/2"(d)

NUMBER 880086

### G. Large Extra Shelf

#### PART 7

37"(h) x 34"(w) x 19"(d)

NUMBER 880087

\*Unit does not accommodate casters.  
Some assembly required.

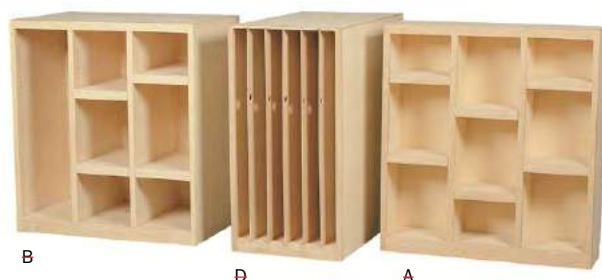

# BEST TAOS WATERCOLOR TABORET

Shown with Deluxe Table  
Top Easel, sold separately.

(See page 132).



EASELS

138

## Taos Watercolor Taboret

Beautiful oak taboret, perfect for working flat or with the Deluxe Table Top Easel. The Taos Taboret features two sliding top panels that open to a 36" x 24" recessed work area. This unique workstation offers plenty of storage, including three drawers, a double-doored cabinet, and two paper drawers. Will easily hold full sheets of watercolor paper!

- Closed: 41-3/4" x 25-1/2"
- Height w/casters: 33-1/2"
- Top surface: 41-1/2" x 25-1/2"
- Top Panels: 20-3/4" x 25-1/2"
- Drawer Dimensions:
  - 1: 23" x 15-1/2" x 4"
  - 2 & 3: 15-3/4" x 23" x 5"
  - 4 & 5: 23" x 35" x 3.5"
- Cabinet: 24" x 19" x 15-3/4"
- Includes front-locking rubber casters
- Box dimensions: 44" x 30" x 34"
- Shipping weight: 250 lbs.
- Ships assembled by truck
- Lift gate required

NUMBER 880064 

Perfect storage unit and workspace  
for the watercolor painter!



# BEST ARTIST & DONKEY BENCHES

## A. Caballo Bench by BEST

You won't find a better bench! A remarkable easel that does everything and goes anywhere. Attached wheels offer mobility when the bench is folded up. When it is set up, the unit provides a sitting area, a storage drawer and an easel for sketching or painting. For years, Italian bench/easels made of beechwood have been popular in the States. Now, this Old World favorite is not just made better, but the BEST!

- Full height: 52";
- Bench height: 18"
- Offers a 16" long divided supply drawer as well as a 27-1/2" long storage area for the mast and canvas holders
- Maximum canvas height: 27-1/2"
- Packaged in heavy-duty carton for protection
- Shipping weight: 30 lbs.
- Ships partially assembled by UPS
- Box dimensions: 43" x 14" x 6"

NUMBER 886008

## B. Caballito by BEST

The traditional art school bench used for years. Designed for student comfort as well as easy storage in the classroom, the Caballito bench is made of solid oak and oak plywood to provide a great workspace at a very low price.

- Base dimensions: 29" x 13-1/2";
- Bench height: 17-1/4"
- Shipping weight: 16 lbs.
- Ships by UPS, assembly required.
- Box dimensions: 48" x 13" x 3"

NUMBER 886009



**Lyptus® Wood** is a new trend in creating more environmentally responsible products. A premium-grade hardwood, Lyptus® is grown on highly-productive, environmentally friendly plantations in South America. The plantations are a mix of eucalyptus trees and native tropical forest, ensuring a natural ecosystem.

A naturally-occurring hybrid of *Eucalyptus grandis* and *Eucalyptus urophylla*, Lyptus® forests are 11 times more productive than a temperate forest. Thriving in the warm climate of Brazil, Lyptus® trees are ready for harvest in as little as 14-16 years as opposed to 50-70 years in colder regions.

Not only are Lyptus® plantations using land that had become useless by years of intensive logging and farming, but for every two hectares (1 Hectare = 2.471 Acres) of Lyptus® plantation planted, one hectare of new native forest is planted. The mills used to produce Lyptus® Wood use proprietary technology in a sustainable and an environmentally friendly manner. The entire process from planting, to pruning, to manufacturing is carried out with the environment in mind.

**GRAIN:** Straight grain and fine, even texture

**CHARACTERISTICS:** Because trees are hand-pruned throughout their growing years, wood is very uniform and has fewer knots.

**DURABILITY:** Lyptus® has similar density, strength and technical properties as hardwood maple. Lyptus® is about 45% heavier than Mahogany, the boards are much straighter, flatter, and smoother.

**COLOR:** The color of Lyptus® varies from pink to pale red-brown with dark pink variations.

**FINISHING:** Lyptus® is receptive to all common types of finishing including both water and solvent based lacquers, various types of pigments, oils and waxes.

**Please note:** that there may be natural variances in the color of our Lyptus® Wood Easels and an occasional change in logo placement. These variances are to be considered a testament to the uniqueness of each easel and not a defect.



## Richeson Lyptus Wood Santa Fe II Easel

This easel is excellent for most large work. An artist can work sitting or standing, with a variety of easily adjusted settings and angles. It features a double laminated quad base, side frames and sturdy H-frame construction. An adjustable extension on the main frame allows added solidity for larger canvases. The Lyptus Santa Fe II comes with two top canvas holders. The self-leveling bottom tray/palette features a melamine paint mixing surface with two large stainless steel canisters. Its marine style winch raises and lowers easily allowing works weighing up to 200 lbs. Also, the plastic front locking casters offer an ease of mobility.

- Base width/depth: 24" x 30"
- Minimum easel height: 129"
- Max. canvas height: 106"
- Bottom tray width: 30"
- Maximum easel height: 78"
- Box Dimensions: 75" x 28" x 6"
- Shipping weight: 108lbs.
- Ships by truck, some assembly required

NUMBER 886025 

Lyptus® regrowth from stump of harvested tree.





## A. Richeson Lyptus Wood Dulce Easel

The sliding mast moves independent of the painting tray, offering artists a greater variety of settings in which to work. By extending the mast to its highest point and leaving the painting tray in its lowest setting, artists are able to work on very large canvases. Alternately, by moving the mast to its lowest setting, especially where ceiling height is a concern, artists can work both sitting and standing allowing for great versatility. With its H-frame construction and quad base, this easel offers great stability for working seated or standing. A slide and lock system adjusts the height.

- Maximum canvas height: 84"
- Base width/depth: 21" x 24"
- Compact easel height: 58"
- Extended easel height: 95"
- Box dimensions: 57" x 21" x 4"
- Shipping weight: 28 lbs.
- Ships by UPS, assembly required

**NUMBER 840200**

## B. ~~Richeson Lyptus Wood Giant Dulce Easel~~

~~This sturdy Dulce easel is especially built for larger canvases, yet it has the ability to fold flat for storage!~~

- ~~Maximum canvas height: 85"~~
- ~~Base width/depth: 23" x 30"~~
- ~~Compact easel height: 68"~~
- ~~Extended easel height: 107"~~
- ~~Self-leveling feet~~
- ~~Box dimensions: 70" x 24" x 4"~~
- ~~Shipping weight: 38 lbs.~~
- ~~Ships by UPS~~
- ~~Some assembly required~~

**NUMBER 840201**

## C. Richeson Lyptus Wood Bassett Easel

This easel has a ratchet system for easy canvas height adjustment and goes past a vertical tilt. The sturdy base features leveling feet.

- Maximum canvas height: 39"
- Base width/depth: 20-1/2" x 21"
- Compact easel height: 54-1/2"
- Extended easel height: 86"
- Self-leveling feet
- Box dimensions: 54" x 20" x 5"
- Shipping weight: 20 lbs.
- Ships by UPS, assembly required

**NUMBER 886044**

- *Lyptus® Wood is wood from the eucalyptus tree*
- *A durable hardwood; as hard, if not harder than oak*
- *Its finish resembles either a cherry or mahogany wood*
- *Eucalyptus trees are fully mature and ready to be harvested in only 14-16 years*
- *Lyptus® Wood is a renewable resource: trees sprout from the stumps of previously harvested trees*

Lyptus® Wood is an eco-friendly hardwood from Weyerhaeuser. Lyptus® is a registered trademark of Weyerhaeuser. For more information, visit: <http://www.lyptus.com>



# LYPTUS® WOOD H-FRAME EASELS

**H-Frame Easels** are sturdy and solid due to their rectangular frame and rectangular bases. Some models are appropriate for very large canvases. Some H-Frame easels will allow a forward tilt, and some have crank adjustments (See Richeson Lyptus® Wood Santa Fe II) and multiple paint tray features that give artist the flexibility to work large or small on the same easel. Many types of H-Frame easels can be knocked down for easy storage and transport, but please note they are heavier and clumsier in their collapsed state than A-Frame and Single-Mast easels.



### A. Richeson Lyptus Wood Aztec Easel

This adjustable H-frame easel folds flat for easy storage. The bottom tray adjusts with the mast and a wood clamp unit keeps it all secure.

- Maximum canvas height: 51"
- Base width/depth: 20" x 20-1/8"
- Compact easel height: 58"
- Extended easel height: 98"
- Self-leveling feet
- Box dimensions: 60" x 20" x 4"
- Shipping weight: 19 lbs.
- Ships by UPS, assembly required

**NUMBER 886001**

### B. Richeson Lyptus Wood Lobo Easel

Made of Lyptus® wood, this easel is fully adjustable and can be used horizontally for watercolor work, vertically for oils and acrylic, or tilted forward for pastels. The base shelf measures 21-3/4" x 28".

- Maximum canvas height: 60"
- Base width/depth: 24" x 27"
- Horizontal table height: 36"
- Extended easel height: 96"
- Box dimensions: 55" x 29" x 6"
- Shipping weight: 28 lbs.
- Ships by UPS, partial assembly required

**NUMBER 883201**

### C. Richeson Lyptus Wood Belmont Easel

This portable and versatile easel has two plastic wheels for easy mobility. It can be positioned in horizontal, vertical and past vertical positions.

- Maximum canvas height: 72"
- Base width/depth: 19" x 21" x 1/2"
- Horizontal table height: 34"
- Extended easel height: 84"
- Compact easel height: 45"
- Box dimensions: 52" x 27" x 5"
- Shipping weight: 26 lbs.
- Ships by UPS, partial assembly required

**NUMBER 886021**



## A. Richeson Lyptus Wood Cascade Easel

This adjustable lyre easel features vertical tilt and a non-slip ratchet system for easy canvas height adjustment.

- Maximum canvas height: 49"
- Base width/depth: 35" x 31"
- Compact easel height: 67"
- Extended easel height: 85"
- Box dimensions: 66" x 5" x 4"
- Shipping weight: 19 lbs.
- Ships by UPS, assembly required

**NUMBER 886042**

## B. Richeson Lyptus Wood Mantoya Easel

An adjustable A-frame easel with a canvas holder that adjusts on the center mast. Folds flat for storage.

- Maximum canvas height: 46"
- Base width/depth: 26-1/2" x 22-1/4"
- Extended easel height: 67"
- Box dimensions: 61" x 6" x 4"
- Shipping weight: 13 lbs.
- Ships by UPS, assembly required

**NUMBER 886002**

## C. Richeson Lyptus Wood Navajo Easel

This easel adjusts easily to a variety of positions for sitting or standing and folds flat for storage.

- Maximum canvas height: 41-1/2"
- Base width/depth: 27-1/2" x 22"
- Extended easel height: 58"
- Box dimensions: 53" x 4" x 3"
- Shipping weight: 8 lbs.
- Ships by UPS, assembly required

**NUMBER 885301**

## D. Richeson Lyptus Wood Lancaster Easel

Great for the young student, it features a bottom tray which has a slot for brushes and pencils. A wood clamping unit secures the tray, and the bottom canvas holder adjusts on the center mast.

- Maximum canvas height: 49"
- Base width/depth: 22-3/4" x 33"
- Extended easel height: 60-1/2"
- Box dimensions: 64" x 5" x 3"
- Shipping weight: 15 lbs.
- Ships by UPS, assembly required

**NUMBER 886034**

**A-Frame Easels** use their triangular support to provide a stable base for your painting. These easels are commonly referred to also as Lyre easels. Most versions of this easel can be stored flat. They normally do not allow for a forward tilt at the top of the painting, although some of the "adjustable" lyres will sometimes allow some vertical tilt for pastel work. Canvas size can be somewhat limited compared to an H-Frame easel. The design of this easel, with a single leg in the back, allows you to use it in a corner or in tight spaces.



# TABLE TOP EASELS

- Great for plein air painting or travel
- Lightweight for students who need to bring an easel with them
- Easily packed to use for store or conference displays
- Inexpensive and very versatile
- Great for artists who have no floor space!

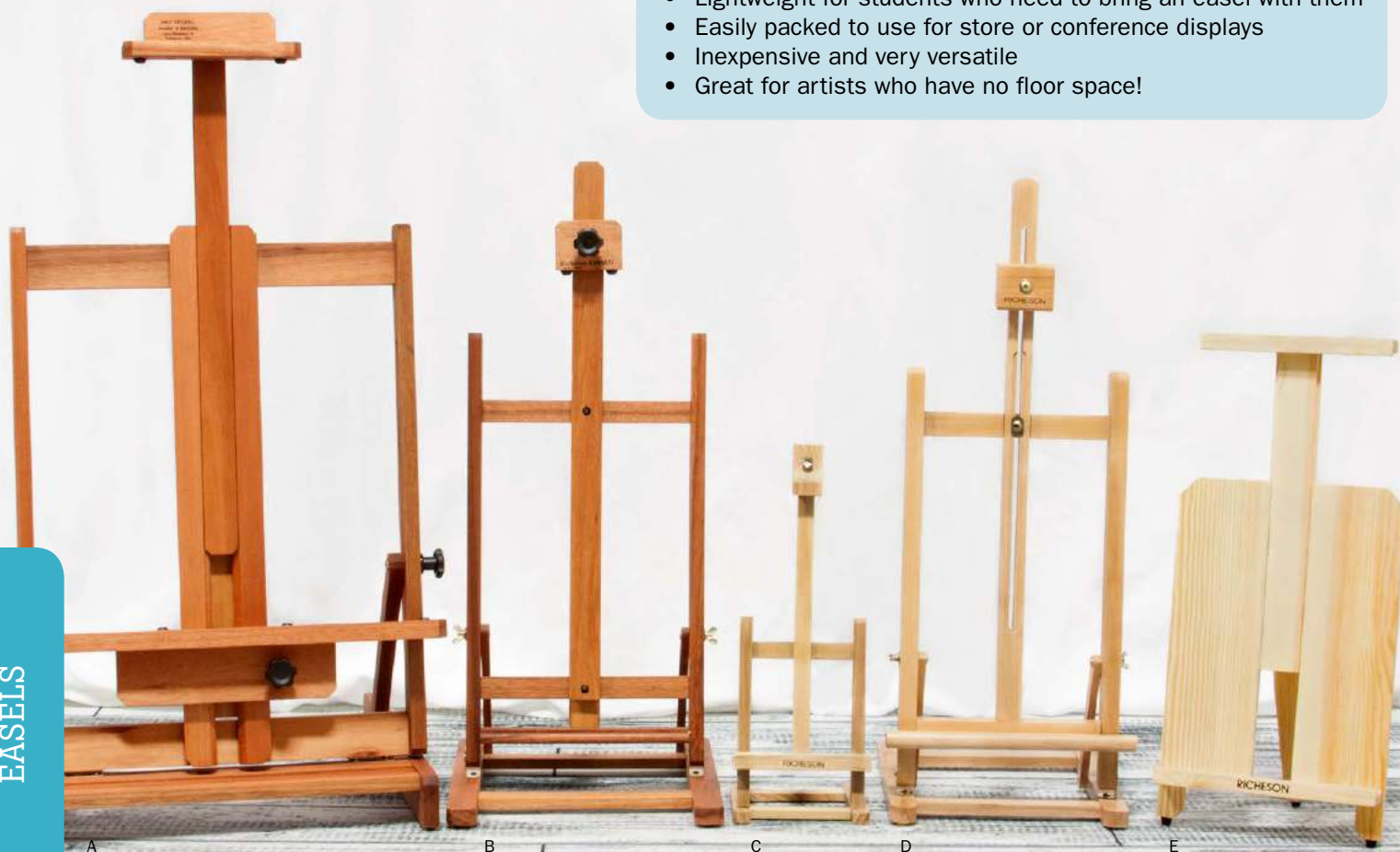

**A. Richeson Lyptus Wood Deluxe Table Top Easel**

- Maximum canvas height: 40"
- Base width/depth: 18" x 18-1/4"
- Compact easel height: 27-1/4"
- Extended easel height: 48-3/4"
- Box dimensions: 28" x 19" x 5"
- Shipping weight: 11 lbs.
- Ships by UPS, assembly required

**NUMBER 844200**

**B. Richeson Lyptus Wood Racine Table Top Easel**

- Maximum canvas height: 24"
- Base width/depth: 12-1/2" x 13-3/4"
- Extended easel height: 30-1/2"
- Box dimensions: 28" x 14" x 3"
- Shipping weight: 5 lbs.
- Ships by UPS, assembly required

**NUMBER 886031**

**C. Richeson Bennett**

- Maximum canvas height: 12"
- Base width/depth: 6-1/8" x 5-1/4"
- Extended easel height: 17-1/2"
- Box dimensions: 18" x 7" x 3"
- Shipping weight: 1 lb.
- Ships by UPS, assembly required

**NUMBER 696011**

**D. Richeson Seneca**

- Maximum canvas height: 22"
- Base width/depth: 11" x 12-1/2"
- Compact easel height: 30"
- Extended easel height: 39"
- Box dimensions: 27" x 12" x 4"
- Shipping weight: 4 lbs.
- Ships by UPS, assembly required

**NUMBER 696008**

**E. Richeson LaVara**

- Maximum canvas height: 24"
- Base width/depth: 10-1/4" x 10"
- Compact easel height: 16-3/4"
- Extended easel height: 27"
- Box dimensions: 17" x 11" x 3"
- Shipping weight: 3 lbs.
- Ships by UPS

**NUMBER 885101**



# RICHESON PINE EASELS

Richeson Pine Easels are a supreme easel choice for those artists looking for a high quality easel in an economically-priced wood. These are great for students and weekend-artists alike!



## A. Richeson Pine Adjustable Lyre Easel

- Minimum canvas height: 8"
- Maximum canvas height: 77"
- Base width/depth: 26" x 30"
- Compact easel height: 67"
- Extended easel height: 100"
- Top canvas holder: 14" wide
- Bottom canvas holder: 26" wide
- Folds flat for storage
- Box dimensions: 65" x 27" x 4"
- Shipping weight: 23 lbs.
- Ships by UPS, mostly assembled

**NUMBER 882250**

## B. Richeson Pine Lobo Easel

- Maximum canvas height: 60"
- Base width/depth: 24" x 27"
- Horizontal table height: 36"
- Extended easel height: 96"
- Base shelf: 21-3/4" x 28"
- Fully adjustable
- Can be used vertically or horizontally
- Partial assembly required

**NUMBER 882255**



Richeson Pine Lobo Easel shown in horizontal position for watercolor

## C. Richeson Pine Dulce Easel

- Maximum canvas height: 84"
- Base width/depth: 21" x 24"
- Compact easel height: 58"
- Extended easel height: 95"
- Great versatility in working height
- H-frame construction and quad base offer maximum stability
- Partial assembly required

**NUMBER 882260**

## D. Richeson Pine Navajo Easel

- Max. Canvas Height: 41-1/2"
- Base Width/Depth: 27-1/2" x 22"
- Extended Easel Height: 58"
- Folds flat for easy storage and transport
- Adjusts easily to a variety of positions
- Can be used sitting or standing
- Partial assembly required

**NUMBER 882265**

# LIGHTWEIGHT DISPLAY EASELS

EASELS

146



## A. Double-Sided Lyptus

Offering two working or display surfaces, this easel makes an elegant stand for holding canvases, drawing boards, newsprint pads, posters, finished paintings and more! Folds flat for easy storage. Great for limited space in classrooms! 4 pegs included.

- Base width/depth: 27.5"/29.5"
- Box dimensions: 72" x 29" x 3"
- Shipping weight: 14lbs.
- Ships partially assembled by UPS

**NUMBER 886005**

## Replacement/Additional Pegs

Pack of 4  
**NUMBER 886060**



## Richeson JJ Easels

Great for plein air painting, these easels are lightweight and easily packed up for travel. They are perfect for students, in-store use and conference displays. These inexpensive and very versatile easels are perfect for artists who have limited floor space!

### B. Richeson "JJ" Easel

- Extended easel height: 64"
- Bagged with header
- Shipping weight: 3 lbs.
- Ships by UPS, assembly required

**NUMBER 696111**

### C. Richeson "JJ" Table Top

- Extended easel height: 21"
- Bagged with header
- Shipping weight: 2 lbs.
- Ships by UPS, assembly required

**NUMBER 696085**

# PLEIN AIR EQUIPMENT

## Richeson Shelf Help®

Expand your outdoor workspace! Shelf Help® is available for right and left handed artists. It works beautifully with our French Easels. Each lightweight aluminum shelf features a slotted side edge to hold up to 10 brushes and comes with a plastic brush holder and two adjustable elastic straps to hold the brush holder and other tools. Shelves are made to attach to most common sized easels and up to two shelves will fit inside most French Easels. Shelf dimensions are : 16-1/4"(L) x 10-1/2"(W).

**NUMBER 696305** Right Hand Shelf  
**NUMBER 696306** Left Hand Shelf



Right hand Shelf Help show on French Easel. French Easel can be found on page 148.

*Great tools for plein air painters!*

EASELS



### A. Colored Metal Stools

These brightly colored stools are great for any studio or office. Adjusts from 19" to 24" tall. Smooth rolling casters make for easy mobility.

- Perfect while painting or at a computer desk
- Great for teen desks and dorm rooms

NUMBER	DESCRIPTION
693001	Black
693002	Red
693003	Blue
693004	Yellow



### B. Steel Stool

~~A heavy duty folding tripod stool with a leather seat. 160lb. capacity. Folded: 22-1/2". Stands: 19-1/2".~~

**NUMBER 694060**



### C. Traditional Wood Stool

This heavy-duty hardwood folding stool features a leather seat and folds compact for storage and transport. 200lb. capacity. Folded: 24". Stands: 19".

**NUMBER 694061**

# PLEIN AIR EQUIPMENT

An artist's work may take him to out of the way places with strange sounding names. Or maybe she's just a few yards down the trail where the angle is better and the light is brighter. Wherever artists may find their vision, our selection of Plein Air Equipment is sure to include the most dependable traveling companions. Whether a beginner or a professional, there is a Plein Air Easel made just for you!

EASELS

148



# PLEIN AIR EQUIPMENT



**A. Richeson Weston Full French Easel**  
(shown above and at left)

- Includes an 11" x 16" wooden palette
- Maximum canvas height: 34"
- Closed dimensions: 16" x 22"
- Shipping weight: 13 lbs.
- Box dimensions: 25" x 18" x 8"
- Ships UPS, assembly required

**NUMBER 696303**

**B. Richeson Weston Half French Easel**

- Includes a hinged wooden palette measuring 11" x 16"
- Maximum canvas height: 34"
- Closed dim: 10-1/4" x 22-1/2"
- Shipping weight: 10 lbs.
- Box dimensions: 25" x 13" x 8"
- Ships UPS, assembly required

**NUMBER 696302**

**C. Richeson DePere Field Sketching Easel**

An easel with adjustable legs. Easy to set up and take down. This lightweight, compact unit is simple to carry and to transport.

- Maximum canvas height: 38"
- Base width/depth: 34" x 34"
- Folds to: 5" x 34" x 3"
- Extended easel height: 73"
- Box dimensions: 24" x 6" x 4"
- Shipping weight: 3 lbs.
- Ships by UPS, assembly required

**NUMBER 696069**

*French Easels can be used as a table top easel when the legs are folded up!*

B

C

*See the Roz Boxes found on page 107. They work great opened up on a French Easel!*

# RICHESON STEEL EASELS



## Italian Steel Tripod Easels

High quality steel easels with an excellent finish and sturdy fittings. For use indoors and out, Richeson's portable steel easels give you the best performance possible. Lightweight aluminum easels may blow over in the wind but the extra weight of steel keeps these easels steady. Adjusts to a horizontal position for watercolor work.

- Maximum canvas height: 29"
- Horizontal table height: 31" – 54"
- Extended easel height: 80"
- Box dimensions: 35" x 5" x 4"
- Shipping weight: 7 lbs.
- Ships by UPS

NUMBER	DESCRIPTION
694050	Aluminum & Chrome
694051	Black & Chrome
694052	Red & Chrome
694053	White & Chrome
694055	Green & Chrome
694056	Yellow & Chrome

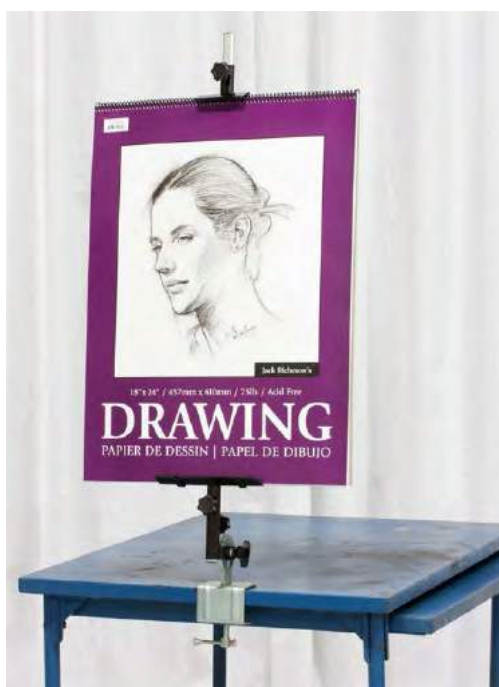

## Italian Table Easel

This black and chrome easel clamps to table tops, chair backs and many other surfaces, whether vertical, horizontal or angled. It's sturdy enough to use for work and attractive enough to use for display. It uses the same gripping device as our large steel easels to firmly hold work in place. Maximum canvas height is 29".

NUMBER 694047

*Wow! Clamps on to virtually any surface!*

# RICHESON STEEL EASELS

## A. ~~The Italian Maestro~~

The Maestro will grace any studio with its elegant styling and solid stability. Its weight and durability make it perfect for heavy use. The shelf increases its utility even more!

- Maximum canvas height: 62"
- Base width/depth: 21-1/2" x 21-1/2"
- Box dimensions: 63" x 9" x 8"
- Shipping weight: 31 lbs.
- Ships by UPS, assembly required

**NUMBER 697001**

## B. ~~The Italian Maestro Jr.~~

- ~~Maximum canvas height: 50"~~
- ~~Base width/depth: 21 1/2" x 21 1/2"~~
- ~~Box dimensions: 62" x 9" x 8"~~
- ~~Shipping weight: 24 lbs.~~
- ~~Ships by UPS, assembly required~~

**NUMBER 697005**

## C. ~~Maestro Metal Shelf~~

~~Dimensions: 19 3/4" x 12".~~

**NUMBER 697002 (SPECIAL ORDER ONLY)**

## D. ~~The Display Easel~~

~~Made from chrome plated and varnished black steel, this is a unique display easel that is attractive and practical. This unit was designed to be used on both sides at once. Depending on the size of the artwork, four pieces can be displayed at the same time.~~

- ~~Base width/depth: 20" x 22"~~
- ~~Extended easel height: 72"~~
- ~~Box dimensions: 81" x 2" x 2"~~
- ~~Shipping weight: 7lbs.~~

**NUMBER 697096**

## E. ~~Italian Steel Lyre Easel~~

~~A heavy duty steel A frame easel which is perfect for classroom or studio use. It can be taken down and set back up with ease. Ships fully assembled.~~

- ~~Maximum canvas height: 62"~~
- ~~Base width/depth: 26" x 25"~~
- ~~Extended easel height: 83"~~
- ~~Box dimensions: 66" x 22" x 3"~~
- ~~Shipping weight: 21lbs.~~

**NUMBER 694063**



# RICHESON WOODEN PRINT RACKS



## **Portable, knock down storage!**

*Great for conferences, exhibits at malls or art shows, and great when you have to transport and set up a show by yourself!*

### **Richeson Ambrosia Print Rack**

- Base width/depth: 37" x 22"
- Rack height: 32"
- Gusset: 6-7/8"
- Box dimensions: 36" x 33" x 4"
- Shipping weight: 28 lbs.
- Ships by UPS
- Assembly required

**NUMBER 886011**



### **Richeson Small Galestio**

- Base width/depth: 20" x 15-1/2"
- Rack height: 31"
- Box dimensions: 37" x 21" x 3"
- Shipping weight: 11 lbs.
- Ships by UPS
- Assembly required

**NUMBER 886010**

### **Richeson Medium Galestio**

- Base width/depth: 23-3/4" x 16-1/2"
- Rack height: 33-3/4"
- Box dimensions: 39" x 25" x 3"
- Shipping weight: 15 lbs.
- Ships by UPS
- Assembly required

**NUMBER 886016**

### **Richeson Large Galestio**

- Base width/depth: 37" x 17"
- Rack height: 37"
- Box dimensions: 44" x 38" x 3"
- Shipping weight: 19 lbs.
- Ships by UPS
- Assembly required

**NUMBER 886019**



# RICHESON METAL PRINT RACKS



## Richeson Black Steel Print Rack

- Base width/depth: 34" x 18"
- Rack height: 32"
- Gusset: 6"
- Box dimensions: 34" x 23" x 4"
- Shipping weight: 16 lbs.
- Ships by UPS
- Assembly required

**NUMBER 696070**

## Richeson Canvas Print Racks

These great print racks are lightweight and fold flat for easy storage! They have a support bed of black canvas that is sewn on to a sturdy, black 5/8" aluminum tube frame with rubber feet. All have hand holes for carrying. A great way to display or store prints and paintings! Carton dimensions are before "inner boxing".

**All 3 sizes ship UPS.**

## Small Rack – 4" gusset

Dimensions: 18"(w) x 20"(h)  
Box Dims/WT: 24"x20"x3"; 4lbs.

**NUMBER 692042**

## Medium Rack – 6" gusset

Dimensions: 24"(w) x 37-3/4"(h)  
Box Dims/WT: 26"x 26"x3"; 8lbs.

**NUMBER 692043**

## Large Rack – 6" gusset

Dimensions: 36"(w) x 38-1/2"(h)  
Box Dims/WT: 37"x26"x3"; 11lbs.

**NUMBER 692044**

# WOOD, MELAMINE & PLEXI PALETTES



## A. Wooden Rectangular Palettes

For those who don't like to cut corners!

NUMBER	DIMENSIONS
696038	9" x 12"
696039	10" x 14"
696026	12" x 16"

## B. Wooden Oval Palettes

Gracefully curved to fit the hand better, reducing fatigue.

NUMBER	DIMENSIONS
696025	9" x 12"
696036	10" x 14"
696037	12" x 16"

## C. Wooden Armed Palettes

This spacious old-world palette is designed for comfort and reduced fatigue. Even though it is larger and heavier than other palettes, its shape and balance (due to a counter-weight) help distribute the palette's weight over the whole arm instead of just at the wrist. Must specify right or left grip. Measures 26-1/2"(w) x 18"(l).

NUMBER	DESCRIPTION
696023	Right Hand Grip (For Left-Handed Painter)
696040	Left Hand Grip (For Right-Handed Painter)

## D. Melamine Rectangular Palettes

A smooth melamine surface on both sides of the palette accommodates both left and right handed painters. Include a neoprene thumb insert for comfort and ease of use.

NUMBER	DIMENSIONS
696050	9" x 12"
696051	11" x 14"
696052	12" x 16"

## E. Melamine Oval Palettes

Double-sided melamine palettes gracefully curved to fit the hand better, reducing fatigue. Suitable for both left and right handed painters and include a neoprene thumb insert for comfort and ease of use.

NUMBER	DIMENSIONS
696055	9" x 12"
696056	11" x 14"
696057	12" x 16"

## F. Melamine Armed Palettes

Designed for comfort and reduced fatigue. Its shape and balance help distribute the palette's weight over the whole arm instead of just at the wrist. Includes a neoprene thumb insert. Must specify right or left grip. Measures 26"(w) x 17"(l).

NUMBER	DESCRIPTION
696060	RH Grip (For LH Painter)
696061	LH Grip (For RH Painter)



## G. Clear Oval Plexi Palettes

These amazing palettes come in three sizes for your convenience. Use them as a tool to check your color over your painting without committing too quickly and having to repaint!

NUMBER	DIMENSIONS
696065	8-1/2" x 11"
696066	11" x 14"
696067	17" x 24"

# PALETTE CUPS

All of the palette cups offered below feature a bottom clip that slides over the edge of a palette. The primary use of these cups is to hold turpentine, linseed oil or other mediums.



## A. Pot Shaped Palette Cups (open/no cover)

NUMBER	DESCRIPTION
694001	Small single 1-1/4" diam. 1/2" deep
694002	Small double 1-1/4" diam. 1/2" deep
694013	Large double 2-1/4" diam. 3/8" deep

## B. Flat Open Palette Cups (no cover)

NUMBER	DESCRIPTION
694019	Large single 2-1/4" diam. 3/8" deep
694020	Large double 2-1/4" diam. 3/8" deep
694021	Small single 1-1/4" diam. 3/8" deep

## C. Cups With Brass Cover

NUMBER	DESCRIPTION
694003	Small single 1-1/4" diam. 1/2" deep
694004	Small double 1-1/4" diam. 1/2" deep
694017	Large double 2-1/4" diam. 3/4" deep
694018	Large single 2-1/4" diam. 3/4" deep

## D. Plastic Cups With Cover

NUMBER	DESCRIPTION
694005	Large double 2" diam. 1" deep
694007	Large single 2" diam. 1" deep



*Great for making skins!*

## Tri-Art Non-Stick Palettes

The Tri-Art non-stick palette is easy to clean, practical and is an essential addition to your acrylic painting equipment! It is a re-useable, economical and environmentally friendly alternative to other palettes on the market.

- Great tool for painting or crafting
- Makes palette cleaning a breeze!
- Acrylic paint can be easily removed
- Use the peeled-off leftover paint for collage and texturing or create acrylic gel transfers and acrylic skins!

NUMBER	DIMENSIONS
0100003545	12" x 16"
0100003546	16" x 24"

# PORCELAIN PALETTES

With over 30 years of painting experience, Tom Lynch and Stephen Quiller realized they needed something more than the ubiquitous lightweight plastic palette. They wanted something sturdier, a palette with a bit more “heft” to prevent slipping and sliding. They sought a surface that would keep the colors moist longer and, unlike plastic, would not cause the watercolors to bead and separate. All of this was accomplished with their signature palette designs.

## The Ultimate Palettes for the Water Media Studio



### Stephen Quiller Porcelain Palette

Quiller's theories and this 13" x 13" non-staining porcelain palette can change the way artists think about color.

*"This porcelain palette is truly the ultimate watercolor painter's tool. Its beautiful white surface allows me to see accurately the transparent mixed pools of color. The surface does not scratch and colors will not stain the surface. This sturdy palette will not shift on the table while actively painting. I use this palette in my studio and it should last a lifetime!"*

- Heavyweight for the studio; will not slide around during use; weighs 7lbs.
- 32 wells for color, one large mixing area, and a large plastic dust cover for additional mixing and better storage. (Cover serves to keep dust off paint; does not seal.)
- Great for acrylic and casein paint – a wet sponge and the cover will keep paint from drying during short breaks
- Includes instructions on how to organize your palette for mixing primary, secondary, and intermediate colors

**NUMBER 420751**

See page 158 for the plastic Quiller and Quiller Traveler Palettes.

### Tom Lynch Porcelain Palette

Brushes will glide across the slick surface of this 12" x 16" porcelain palette!

- Heavyweight for the studio; will not slide around during use
- 20 outer wells for color and one large mixing area
- Large front well for extra colors or glazing puddle
- Large plastic dust cover for extra mixing area and better storage
- Corner holes to hold 8 brushes
- Weighs 7lbs.

**NUMBER 420750**

### S-Shaped 32 well Palette

Nothing works like porcelain for water media! Three large areas for mixing. Small wells are ideal for individual colors. 16-3/8" x 11-3/4".

**NUMBER 420753**



# PORCELAIN PALETTES

Hand glazed in China, these pure white porcelain items are great for mixing inks, dyes and water media without staining. For artists painting on porcelain dolls or dishware, these palettes offer the advantage of knowing what the color will look like on a similar surface. Not only are they functional, they also look great wherever you need that "artistic" touch.



(Note: Plastic covers not shown on F, G, L and N.)

NUMBER	DESCRIPTION	DIMENSIONS
<del>A. 420702</del>	<del>Small Vase (Brush Holder)</del>	<del>3-1/2"(w) x 4"(h) x 2-1/2"(o)</del>
<del>B. 420703</del>	<del>Brush Holder (Esquilligus)</del>	<del>3-1/2"(w) x 6"(h)</del>
C. 420704	7 Well Round w/Porcelain Cover	8-1/4"(w) x 1-3/4"(h) x 3"(h) w/cover
D. 420705	5 Round/5 Slant Well Palette	7"(w) x 3/4"(h) x 3-3/4"(d)
E. 420706	7 Well Flower Mixing Tray	4-3/4"(w) x 3/4"(h)
F. 420707	11 Well Round w/Plastic Cover	7-1/4"(w) x 1"(h) w/cover
G. 420708	7 Well Round w/Plastic Cover	7-1/8"(w) x 1-1/8"(h) w/cover
H. 420709	6 Small Ceramic Nesting Bowls	3"(w) x 3-1/8"(h) stacked
I. 420710	6 Large Ceramic Nesting Bowls	3-7/8"(w) x 3-1/2"(h) stacked
J. 420711	Brush Holder - 6 Scoops	1-1/4"(w) x 2"(h) x 5-1/2"(d)
K. 420712	3 Well Round Mixing Bowl	6"(w) x 2-5/8"(h)
<del>L. 420713</del>	<del>5 Well Round w/Plastic Cover</del>	<del>7-1/4"(w) x 1-1/4"(h)</del>
M. 420714	Ceramic Mortar and Pestle	4-3/4"(w) x 2-1/2"(h)
N. 420715	12 Well Round w/Plastic Cover	7-1/2"(w) x 1"(h)



## Miniature Porcelain Trays

Excellent for artists on the go! With all the benefits of larger porcelain products, they also have the added benefit of being small enough to carry anywhere.

### O. 12 Well Small Porcelain Tray with Lid

Dimensions: 4" x 3-1/4" with 5/8" wells

**NUMBER 420716**

### P. 12 Well Medium Porcelain Tray

Dimensions: 4-3/4" x 3-1/2" with 3/4" wells

**NUMBER 420717**

### Q. 22 Well Large Porcelain Tray with Lid

Dimensions: 7" x 4-3/4" with 5/8" wells and a large rectangular well

**NUMBER 420718**

# PLASTIC PALETTES

Plastic palettes and trays – they're a playground for color, an open field where the imagination can bloom. A splash of color against the white plastic tells the artist much about hue, mood and texture. Jack Richeson & Co. offers a broad selection of trays and palettes to appeal to professionals, students, and even children. Plastics provide excellent margins for dealers. Of course, we always consider the environment at Jack Richeson & Co., so we use recycled plastic where feasible and grind and recycle all plastic waste.



## A. Quiller Covered Palette

The Quiller Palette, designed around the color theories of noted artist Stephen Quiller, provides wells for primary, secondary and intermediate colors, as well as twelve extra wells for additional colors. It has a large central mixing area and outside wells for gouache or earth colors. The Quiller Palette comes with valuable information on how to organize your palette for optimal color relationships and is an essential tool for the watercolorist looking for convenience.

**NUMBER 400237** 14-3/4" x 14-3/4" x 7/8"

## B. Quiller Covered Travel Palette

The color theory of Stephen Quiller has unlocked limitless possibilities. By designing a smaller version of the Quiller Palette, artists can take these possibilities anywhere. This travel version will fit in many French Easels on the market. Instructions on how to arrange the palette are included.

**NUMBER 400250** 11-3/8" x 14-3/8" x 7/8"

## C. Richeson Covered Palette

A large tray with 22 wells for color and a large central mixing area, the Richeson Palette is perfect for organizing your own color system. Use in the studio, or with its secure lid, take your colors into the field. The rounded edges will not harm your brushes.

**NUMBER 400207** 16" x 12-1/4" x 7/8"

## D. Zoltan Szabo Covered Palette

This palette is everything a good water-color palette should be. With both big and small wells for mixing color and using larger brushes, the wells have a sloping configuration and a deeper "pool" to keep paint from evaporating. There are no sharp edges which protect your brushes and is easy to use with a palette knife. To top it off, it is sized to fit into a backpack or briefcase.

**NUMBER 101002** 12-1/2" x 8-3/4" x 3/4"

# PLASTIC PALETTES



## A. "Creative Mark" Palette

This watercolor palette features 40 small square wells and 4 large mixing areas. It includes a cover to keep paints moist and provides an extra mixing surface. Measures 12" x 16".

**NUMBER 400254**

## B. 20 Well Tray

A tray that offers both large and small mixing wells with rounded edges that will not harm brushes. Easy to clean. Measures 10" x 13".

**NUMBER 400205**

## C. 21 Well Flower Palette Tray

This heavy-duty white plastic 8-1/4" x 13-1/2" palette has the added benefit of an attached flower dish.

**NUMBER 400246**

## D. 17 Well Oval Palette

This sturdy, lightweight watercolor palette has plenty of wells for mixing as well as 12 small wells for holding paint. Measures 9" x 13".

**NUMBER 400236**

## E. 17 Well Rectangular Palette

This sturdy, lightweight palette features 12 small wells for holding color and 5 large wells for mixing. Measures 9-1/2" x 13-3/4".

**NUMBER 400233**

## F. 9 Well Rectangular Palette

This heavy-duty rectangular tray has 5 round paint wells and 4 square paint wells. The tray also offers a large area for mixing. Measures 6-1/2" x 9-1/2".

**NUMBER 101075**

## G. 9 Well Oval Plastic Palette

This heavy-duty 9 well oval plastic palette offers a convenient mixing area as well as 9 wells for paint. Measures 8" x 11".

**NUMBER 101089**

## H. 7 Well Oval Plastic Palette

Beautiful heavy-duty 7 well plastic palette in the popular oval shape. Palette offers a large mixing area. Measures 6-3/4" x 9".

**NUMBER 101091**

## I. 12 Well Oval Plastic Palette

This heavy-duty plastic palette is attractively shaped like a traditional artist palette. Tray has 12 paint wells and a large area for mixing. Measures 10-1/2" x 14-1/4".

**NUMBER 101088**

## J. Little Palette Tray

5-1/2" x 7-1/4" heavy-duty coated white aluminum palette.

**NUMBER 400299**

# PLASTIC PALETTES



## Folding Watercolor Palettes

Each folding palette has numerous wells for color, and room to carry small tubes of paint or brushes. All easily fit into a backpack, briefcase or toolbox.

NUMBER	DIMENSIONS
A. 400231	10" x 9"
B. 411254	10-1/2" x 12"
C. 400230	11-3/4" x 10-1/2"

PALETTES

160



### 6 Well Tray

Available in a heavy-duty plastic and an economical lightweight plastic. Measures: 3-5/8" x 5-1/4".

NUMBER	DESCRIPTION
400202-12	Heavy-duty (pack of 12)
101016-144	Economy (pack of 144)



### 5 Well Slant Tray

This 4-1/2" x 7-1/2" heavy-duty plastic mixing tray has 5 round wells for paint plus 5 slant wells for mixing.

**NUMBER 101008**



E

D

### Round 10 Well Tray

This pure white tray is available in an easy to clean heavy-duty plastic and an economic lightweight plastic. The heavy-duty version shown is 6-7/8" in diameter and features brush rests along the outer edge of the tray.

NUMBER	DESCRIPTION
D. 400220-12	Heavy-duty Tray w/Cover (Pack/12)
E. 101014-144	Economy Tray (Pack/144)
400201-12	Heavy-duty Tray (Pack/12)
400219-12	Clear Cover only (Pack/12)



### 8 Well Slant Tray

This 4" x 12" heavy-duty plastic mixing tray has 8 round wells for paint plus 8 slant wells for mixing.

**NUMBER 101000**



### 9 Well Tray

A 3-5/16" x 7-1/8" heavy-duty pure white plastic tray.

**NUMBER 400204-12** (pack of 12)



# PLASTIC PALETTES



## A. Muffin Trays

Very economical, these white plastic pans are ideal for mixing or holding up to 2oz. Teachers use them to distribute paint in the classroom and clean-up is easy. Available in four sizes, sold in packs of 12.

NUMBER	DESCRIPTION
101010-12	2 Well (pack of 12) 7-1/4" x 3-1/2"
101011-12	4 Well (pack of 12) 7-1/4" x 7-1/4"
101012-12	6 Well (pack of 12) 7-1/4" x 10-3/4"
101013-12	9 Well (pack of 12) 10-3/4" x 10-3/4"

## Tempera Cake Trays

These trays are made from a heavy-duty white plastic that is sure to withstand even the toughest little painter.

NUMBER	DESCRIPTION
B. 101256-12	Large 6 Well Tray (Pack/12)
C. 101263-12	Small 6 Well Tray (Pack/12)
D. 101408-12	8 Well Tray (Pack/12)



## E. 7 Well Flower Dish

A medium weight, porcelain-like plastic dish 6" in diameter.

**NUMBER 400232**

## F. 13 Well Flower Dish

Heavy, porcelain-like plastic dish 6" in diameter.

**NUMBER 400234**

## G. 9 Well Flower Dish

Lightweight plastic, 5-3/8" diameter.

**NUMBER 400235**



# PALETTES AND TRAYS

## Aluminum Trays

These rust proof aluminum trays are available in three different sizes and are easy to clean.

### NUMBER DESCRIPTION

- A. 400251 10 Well - 6-3/4" diam.
- B. 400252 6 Well - 5-3/8" diam.
- C. 400253 6 Well - 3-1/2" x 5-1/4"

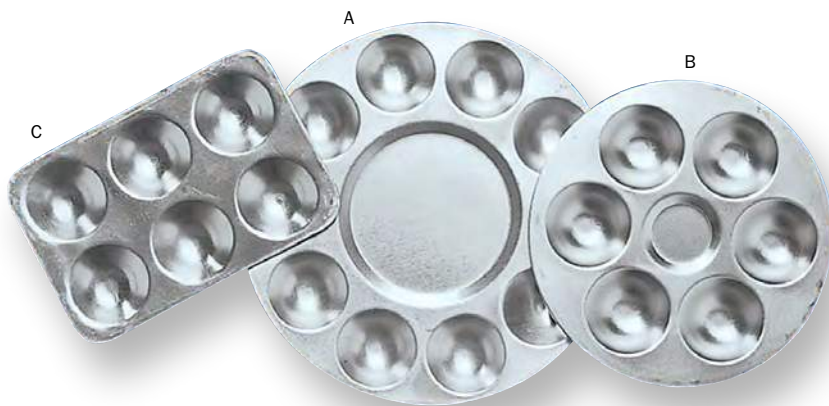

## Butcher Trays

These Chinese porcelain trays have a convex center so water will run to the edge. They may occasionally come with chips on the rim, but this is normal and will not affect the working surface for the artist.

### NUMBER DESCRIPTION\*

- D. 400239 7-1/2" x 11"
- E. 400240 11" x 15"
- F. 400238 13" x 17"

\*Measurements are approximate.



## G. Paper Soaking Trays

Designed for children using finger paints, these trays can also be used for soaking paper, working with clay, marbling paper, puzzles or painting.

### NUMBER DESCRIPTION

- 101036 .045mil  
32" x 24-1/4" x 1-3/4"
- 101037 .060mil 12" x 18" x 1"
- 101038 Boxed Tray (101036)
- 400225 .020mil 23" x 16" x 1-3/8"



## Water Cups

Cups are 3-1/2" in diameter and 1-1/8" deep.

### NUMBER DESCRIPTION

- H. 400203-12 Heavy-duty cup (Pk/12)
- I. 101015-144 Economy cup (Pk/144)



## J. Paint Dispenser

A great way to mix, store and dispense paint, glue, and other liquids! This 12 oz. plastic container is equipped with a wide mouth for easy filling. Marked in 1 oz. increments with an attached lid that seals tightly so paints won't dry out! Sold in packs of 12.

NUMBER 400216-12

# LOCK BOX PALETTE & TRAYS

## The Lock Box

The Lock Box is a fantastic palette that allows artists on the move to store and transport their paint. It keeps oils and acrylics moist for up to 30 days!

Teachers love it for distributing paints to students in the classroom. The top of this 11-1/2" by 1" thick unit locks in position with a secure slide fastener. Inside, paints can be stored in a circular plastic palette or on mixing paper.

It's a perfect container for acrylics, watercolors, oils, and gouache. With wet sponge strips in place, paint stays useable for weeks, helping to eliminate wasted paint.

\*Unless stated, disposable mixing sheets not included.

NUMBER	DESCRIPTION
A. 400208	Lock Box w/storage tray (#400213) & 10 mixing sheets
B. 400197	Lock Box w/plastic slant palette insert (#400213)
C. 400199	Lock Box w/clear plexi palette insert (#400198) and a plastic slant palette insert (#400213) for water media.
D. 400228	Lock Box w/plastic tempera cake insert (#400206)
E. 101259	Lock Box w/6 large tempera cakes in tray
F. 400229	Lock Box w/40 mixing sheets
G. 400198	Plexi Palette Insert
H. 400206	Plastic Tempera Cake Insert
I. 400213	Plastic Storage Slant Insert
J. 400200	Refill pack of 40 mixing sheets
K. 400209	Refill pack of 10 mixing sheets
L. 400196	Lock Box Sponge pack of 5
M. 400214	Empty Lock Box



# CHILDREN'S PAINTING ACCESSORIES

## A. Multi Color Trays

Brightly colored trays work well for a range of uses. Five assorted colors come shrinkwrapped together. Outer dimensions: 10-1/2" x 15" Inner dimensions: 8-1/4" x 12"

**NUMBER 400995** (Set of 5)

## B. White Plastic Trays

Heavy-duty plastic trays in large and small sizes.

**NUMBER 101020** 10" x 12-1/2" x 1-1/2"

**NUMBER 101021** 13" x 18" x 1"

## C. Colored Sorting Bowls

Six colorful bowls are great for sorting and color recognition. They can be used to hold liquids for art use or beads for crafting. Bowl dimensions: 6-1/4" diameter by 1-3/4" high.

**NUMBER 400266** (Set of 6)

## D. Plastic Water Pots

Wide-based, extra sturdy plastic pots are stackable for storage! Multi-color set includes white, black, yellow, green, red and blue. Dimensions: 4-3/4" diameter by 3-1/2" high.

**NUMBER 400990** (Multi-Color Set of 6)

**NUMBER 400991** (Red Set of 6)

## E. Disposable Water Cups

These waterproof coated paper cups are great for classroom use. Inexpensive, they easily handle water as well as paint and can be disposed of at the end of class! Cups measure 2-1/2" diameter by 1" deep and can hold approximately 2 ounces of fluid.

NUMBER	DESCRIPTION
694023-100	Pk/100
694023-1000	Pk/1000

\*Shipped in 10 packs of 100.



# NEATNESS JARS & MATS

These Neatness Jars are great for use with our Stubby Brushes and Tempera Cakes!



## Neatness Jars with Lids

Look Mom, no spills! Designed for classroom use, we have since learned that these jars are great everywhere. The base is made of heavy semi-flexible transparent plastic and will hold most liquids, temperas and paints. The inner design of these colorful lids makes it almost impossible to spill contents. Holds 8 ounces.

NUMBER	LID COLOR
401010	Transparent
401011	Blue
401012	Red
401013	Black
401014	Yellow
401015	Green
401016	Orange
401017	Turquoise
401018	White
401019	Violet
401020	Brown



## Neatness Jar Trays

This 5" wide by 18" long plastic tray will accept 6 jars. In a tray, the jars are easy to move from table to table or easel to sink. Neatness Jar trays will fit into many of the children's easels on the market.

NUMBER	DESCRIPTION
401000	Tray filled with 6 jars (3 primary, green, black, white)
401003	Two trays filled with 12 jars (1 of each of 12 colors)
401002	Empty Tray

## Neatness Jar Sets

Boxed jars are a great way to order for schools dividing product up for different classrooms.

NUMBER	DESCRIPTION
401007	12 jars (1 each color, polybagged)
401008	8 jars (red, orange, yellow, green, blue, violet, black and white)
401009	10 jars (red, green, white, black, yellow, blue, orange, violet, brown, and turquoise)

## Neatness Mats

Strong polypropylene mats are perfect for containing mess and keeping your space neat. Conveniently marked with a grid for easy measurements and alignment. Translucent mats are flexible, waterproof, and resistant to glues and stains. Can even be used on overhead projectors. Use them, wash them off, and use them again! Includes 1 each: Yellow, Red, Purple, Blue, and Green. 19-5/8" x 14-1/8" Measuring grid in 3/4" (2cm) squares.

**Note: Not suitable for use as a cutting mat as they will scar.**

NUMBER 401080 (PK/5)



# BRUSH WASHERS



## A. The Ultimate Brush Washer

It's what's on the inside that counts. A cover, a removable sediment tray and a brush holder to protect the brush head from damage, this brush washer has it all. Its good looks are an added bonus! Holds 6-7 brushes. Measures 6-1/4" x 5-1/2".

**NUMBER 411250**

## B. Brush Washer

Made from aluminum, this brush washer features a removable sediment tray and a brush holder to protect the brush head from damage. Measures 4-1/8" x 8-1/2".

**NUMBER 101001**

## C. Richeson Brush Basin

This durable attractive basin with an anti-stick surface accepts any solvent. It suspends the brush bristles in the solvent so they won't bend. Grooves in the bottom aid in cleaning your brushes. Includes an air-tight lid.

Measures: 6-1/2" x 6-1/2" x 3-1/2".

**NUMBER 122050 (INDIVIDUAL)**

**NUMBER 122050-10 (PK/10)**

## D. Plastic Brush Basin

This light blue heavy-duty basin features a cover, 1 bucket, 2 water reservoirs, a 16 well paint tray and 5 holes for brushes in the handle.

**NUMBER 400262**



# SCULPTURE & POTTERY STANDS



## Sculpture and Pottery

Sculpting and pottery often require a lot of careful precision and painstaking detail to convey concepts or reinforce an aesthetic view. In the hands of a fine sculptor or skilled potter, the right tool can mean the difference between true expression and the ordinary.

### A. Handled Bats

Tempered hardboard bats are useful for moving clay work or papier maché around the classroom. They are also useful for transporting pots off the wheel onto the drying rack, as well as for squaring up wheel-thrown pots. These 8" x 8" bats have a non-stick surface. Bulk packed in a carton, perfect for schools.

**NUMBER 150010 (PK/12)**

### B. Sculpture Stand

A solid cast base with non-slip rubber on the bottom, this is 4-3/4" high and features a ball bearing 7" steel top. Shipping weight: 10 lbs.

**NUMBER 698007**

### C. Banding Wheel

Made of heavy-duty plastic, this wheel can be used for sculpture, modeling, and glazing. It is great for both professionals and beginners! 8" diameter.

**NUMBER 400255**

### D. Mini Potter's Wheel

With a 5" top, this is a great starter unit. The heavy cast base, with a ball bearing steel top, is easy to clean. Shipping weight: 5 lbs.

**NUMBER 694072**

### E. Turntable

Designed for beauty and function, this stand can be used for display as well as work. The 11-3/4" turntable is made of black varnished and chrome plated steel and has a 23" wide base. Its height adjusts from 25" to 40". No-slip rubber stops on legs; legs fold for storage. Shipping weight: 25 lbs.

**NUMBER 694077**

### F. Floor Sculpture Stand

Built to handle heavy work up to 250 lbs., this steel floor stand has an adjustable height of 35" to 45". The base of this unit is 20" wide and connected to the adjustable center shaft is a 15-3/4" square top. Rubber locking casters on legs. Shipping weight: 30 lbs.

**NUMBER 698006**

# ARMATURE & ARMATURE WIRE

## Diameter Chart

- .375" ●
- .25" ●
- .188" ●
- .125" ●
- .094" ●
- .078" ●
- .063" ●

## Armature Wire

Armature wire creates the structure that keeps a sculpture together and provides a frame upon which to work. This economical aluminum wire is light weight, very pliable, non-staining and non-corrosive. Suitable for kiln-fired as well as oven-baked projects.

NUMBER	THICKNESS	LENGTH
220390	1/16" (.063)	350'
220391	3/8" (.375)	10'
220392	1/8" (.125)	130'
220393	5/64" (.078)	350'
220394	1/16" (.063)	50'
220395	1/8" (.125)	50'
220396	3/16" (.188)	50'
400330	1/16" (.063)	32'
400335	3/32" (.094)	25'
400340	1/8" (.125)	20'
400350	3/16" (.188)	10'
400360	1/4" (.25)	10'

## Armatures

NUMBER	DESCRIPTION
A. 400370	12" Figure
B. 400371	15" Figure
C. 400380	13" Head and Bust
D. 400381	15" Head and Bust
E. 400382	20" Head and Bust



## Student Modeling Tool Sets

For use with clay, plaster and air-dry materials or copper and aluminum tooling. Tools measure 6" long.

NUMBER	DESCRIPTION
210251	Set of 3
210252	Set of 7
210255	Set of 35 (5 sets of 210252)
210253	Set of 140 (20 sets of 210252)

Note: Color of tools may vary. Sets 210255 and 201253 are bulk packed.



# POTTERY TOOL KITS



## Heavy-Duty Wooden Pottery Kit

This five piece set includes four quality tools made of select hardwood and a 24" long heavy-duty clay cutter. This set is a must for large work. The smallest of the four tools is 10" in length. Packaged in a carton with label showing contents.

**NUMBER 210418**



## Pottery Kit

This kit comes packaged in a segmented reusable pack and contains all the basic tools to get started. Includes header for hanging on pegboard.

**NUMBER 210408**



## Ceramic Tool Set

Includes four 6" boxwood modeling tools and one 8" double end wire tool. These are the most widely used tools for modeling and shaping clay and plaster. Packaged with a hangtag.

**NUMBER 210247**



## Deluxe 8 Piece Basic Potters Assortment

Contains a wooden rib, a forming/model tool, a small trimming loop, a large trimming loop, a pin tool with cover, a wooden scraper/knife tool, a cutting wire, and a sponge. Constructed of white birch, oak, and stainless steel, they are unique in their large size. Everything you need in one great assortment!

**NUMBER 210570**



## Deluxe 12 Piece Basic Potters Assortment

Same great features as set #210570 (at left) featuring extras that will expand your foundation! The set includes a wire clay cutter, 2 brushes, 2 ribs, and essential ribbon, wire-end, needle, and boxwood tools.

**NUMBER 210575**



## Clean-up Tool Kit

Adding detail and smoothing edges is easy with the wide variety of tools offered in this set. Includes 11 different tools. Packaged with a hangtag.

**NUMBER 210509**



## Mini Clay Tool

Includes 6" Boxwood Tools - #s 5,11,18, 24, 27 and 3 Tools from Set #210542. Packaged with hangtag.

**NUMBER 210430**

# POTTERY CUTTING TOOLS

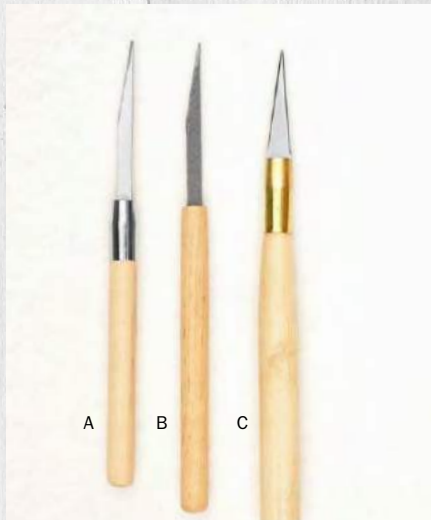

## A. Medium Cut Out Tool

Knife length is 6-3/16", with the cutting area of the blade being 1-1/4". The polished wooden handle features a metal ferrule. Packaged with a hangtag.

**NUMBER 210551**

## B. Short Medium Cut Out Tool

This has the same blade as the 210551 medium tool, but it is mounted onto a shorter handle without a ferrule. Knife length is 5-5/8". Packaged with a hangtag.

**NUMBER 210550**

## C. Small Cut Out Tool

Knife length is 6-1/8", with the cutting area of the blade being 1-7/16". The double edged blade is mounted onto a polished wooden handle with an aluminum ferrule. Packaged with a hangtag.

**NUMBER 210549**



## Fettling Knife

A versatile knife measuring 8-1/8" long. Used to trim and shape clay, plaster, and even styrofoam. This soft blade is 4-1/4" long and has a blunt point. Packaged with a hangtag.

**NUMBER 400303**



## 2" Saber Saw Tool

Knife length is 6", with the cutting area of blade being 2". The blade is mounted to a hand polished wooden handle with a metal ferrule. Packaged with a hangtag.

**NUMBER 210553**

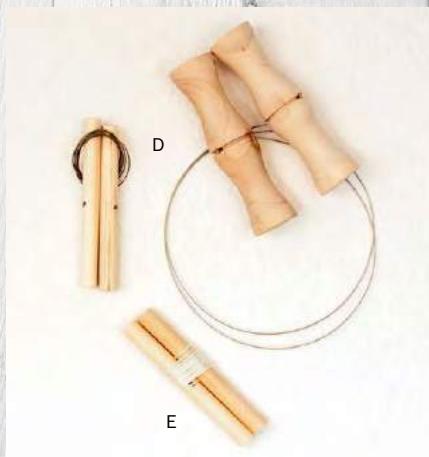

## D. Wire Cutters for Clay

Heavy gauge wire with wooden handles at each end. Makes cutting clay much easier. Packaged with hangtag.

**NUMBER 210411** 18"

**NUMBER 210428** Heavy-Duty 24"

## E. Nylon Clay Cutter

Nylon offers smooth movement through the clay and functions the same as wire. Packaged with hangtag.

**NUMBER 210427** 18"



## Texture Tool Set

Set of 7 tools for creating texture. Packaged with a hangtag.

**NUMBER 210543**



## Hole Cutters

An easy method for cutting holes in wet, thick-walled greenware. Cutting tubes are sharp polished metal set in hardwood handles. Packaged with a hangtag.

NUMBER	DIAMETER
210460	12.8mm
210461	4.5mm
210462	9.652mm
210463	19.81mm
210588	Set of all 4 hole cutters



## Steel Rasps

Perforated rasps for clay and plaster. Packaged with a hangtag.

NUMBER	DESCRIPTION
210416	Small - 6-3/4" long
210417	Large - 8" long
210419	Extra Large - 10" long
210420	Set of all 3 sizes

# SCULPTURE & POTTERY TOOLS



## A. Straight Needles

Use for sgraffito, delicate lace decoration and for removing uneven edges of wheel-thrown items. Packaged with a hangtag.

**NUMBER 210525-12** (5-3/8" long, pack of 12)

## B. Sgraffito Tool

This tool enables a method of sgraffito in which smooth variations of line width can be made within a single stroke. Packaged with a hangtag.

**NUMBER 210465** (6-3/8" long, wood handle)

**NUMBER 210542** (Set of 6)

**NUMBER 210545** (Set of 3)

## C. Pro Tool

This tool is used to cut heavy clay strips, create designs, and create holes. Packaged with a hangtag.

**NUMBER 210529** (6-1/8" long)

## D. Clean-up & Lace Tools

Each of these tools has double working ends for double versatility. Great for detailing, intricate lace work, finishing, etc. Packaged with a hangtag.

NUMBER	DESCRIPTION
210533	Needle/curved blade - 7" long
210532	Needle/curved blade - 6-1/2" long
210534	Small/med. curved blades - 6-1/8" long
210554	Needle/straight blade - 6-1/4" long
210536	Carving tool - 5-3/8" long
210544	Set of 12 clean up tools

## E. Double Ball Stylus

Excellent for sgraffito, embossing, tole painting. Packaged with a hangtag.

NUMBER	DESCRIPTION
210537	Ball size: 0.8mm / 1.2mm - 5-3/8" long
210538	Ball size: 0.8mm / 1.2mm - 6-1/8" long
210539	Ball size: 1.3mm / 1.8mm - 5-3/8" long
210540	Ball size: 1.3mm / 1.8mm - 6" long

## F. Steel Plaster Tools

Hand forged in Italy. Packaged with a hangtag. Shown left to right.

NUMBER	DESCRIPTION
202039	8-1/2" point/square
202040	9-3/8" point/square
202042	9" angle/square
202045	8-1/2" point/square
202048	9" angle/round
202049	8-3/4" point/point
202050	10-3/4" point/square
202053	8-3/4" teeth/teeth
202054	9-7/8" point/square
202055	9-5/8" point/round
202057	9-3/4" point/square
202063	9-1/4" trough shaped
202076	Set of 10 (assorted)
202077	Set of 7 (assorted)

## G. Coarse Riffler Set

For working in tight areas. Includes a carrying case. Packaged with a hangtag.

**NUMBER 210590** (Set of 8)

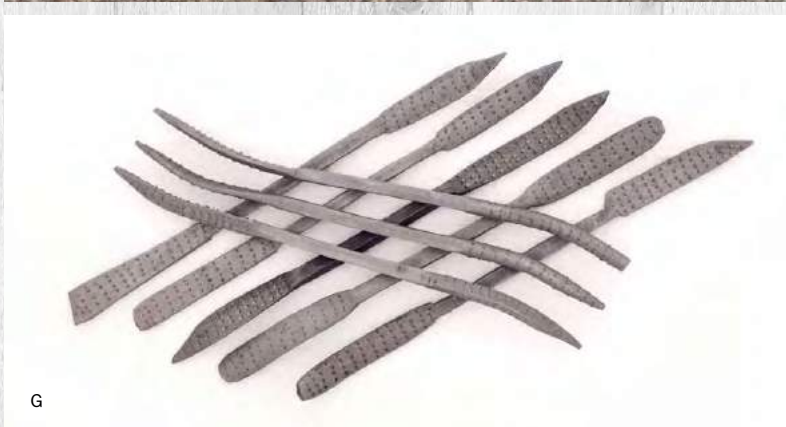

# SCULPTURE & POTTERY TOOLS

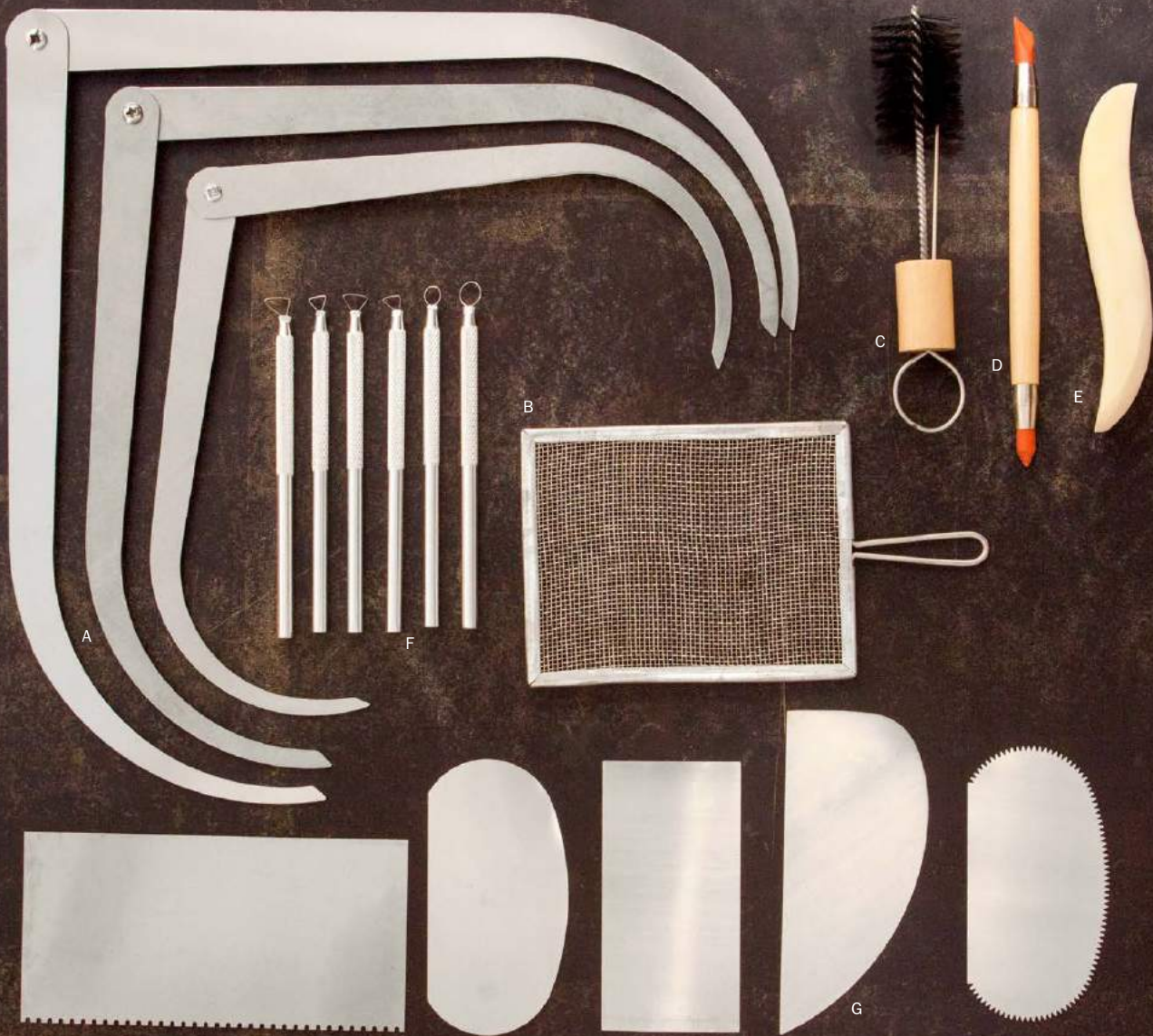

## A. Aluminum Calipers

Lightweight tools for accurate measurements.

NUMBER	DESCRIPTION
210510	Small - measures 8"
210513	Medium - measures 10"
210511	Large - measures 12"

## B. Spatter Seize

This aluminum framed seize offers a 3-3/8" x 5" rectangular wire mesh area to spatter paint from. Can also be used to sift enamels on copper.

**NUMBER 210512** (7 1/8" long with handle)

## C. Speckling Brush

Turn the handle for easy, mess-free, random splatter.

**NUMBER 210480** (6" long)

## D. Wipe Out Tool

Removes wet paint quickly and accurately with two different tips.

**NUMBER 210470** (6-3/8" length)

## E. Sculptor's Thumb

This tool creates those curves not even possible with your hands!

**NUMBER 210450** (5-1/4" length)

## F. Sculpting Tool Set of 6

These mini ribbon sculpting tools are approximately 5-1/4" long. Textured handles for a sure grip.

**NUMBER 210542**

## G. Steel Scrapers

Polished steel shapes for trimming and smoothing. Pictured left to right.

NUMBER	DESCRIPTION
210409	#1 - tooth edge rectangle
210410	#2 - smooth oval
210412	#3 - rectangle
210414	#4 - pointed half moon
210413	#5 - tooth edge oval
210415	Set of 5 (1 of each tool)
210441	Set of 3 (1 each of 210409, 210410, 210414)

# SCULPTURE & POTTERY TOOLS

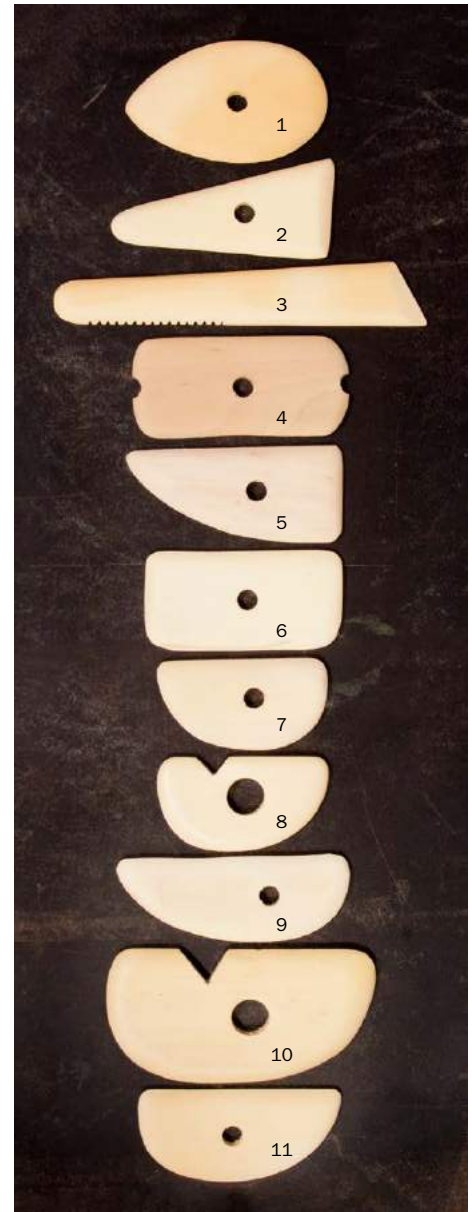
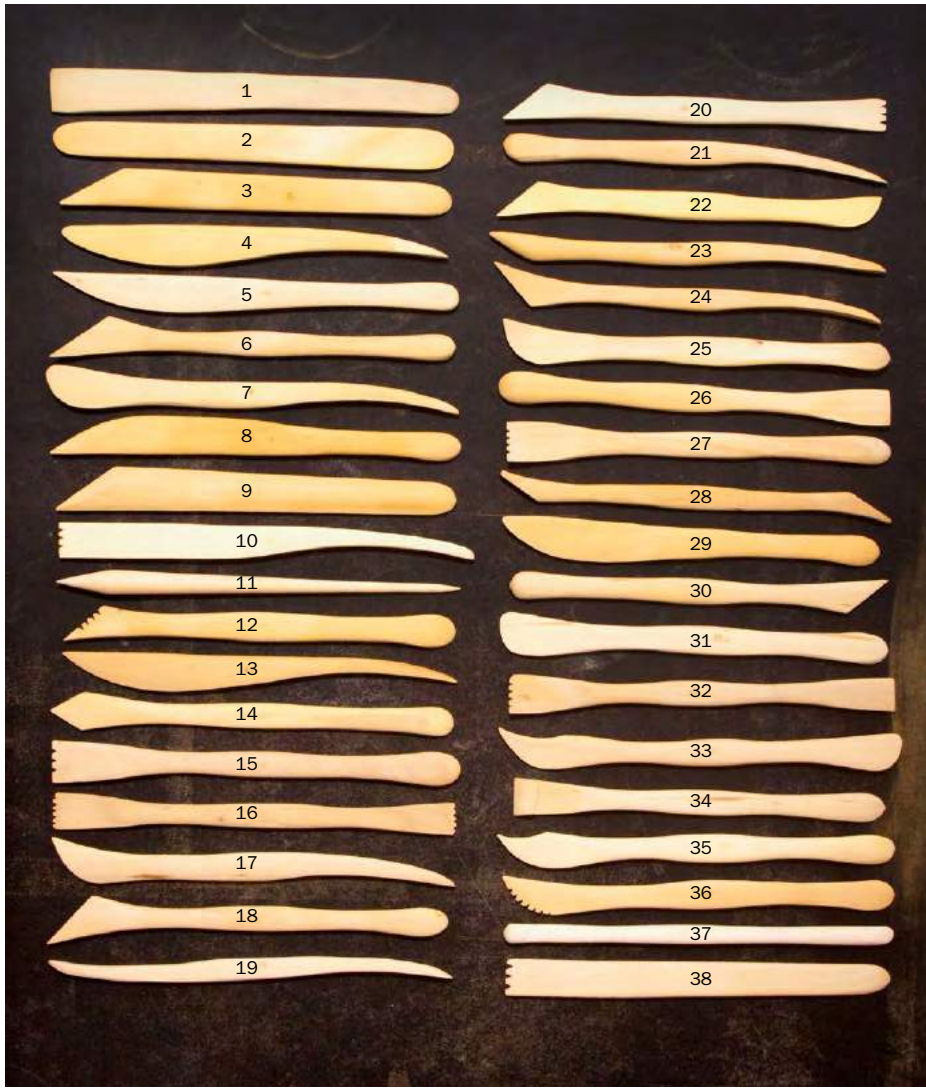

## Boxwood Modeling Tools

Handmade, fine-quality boxwood tools used for shaping and finishing work, on and off the wheel. Both sizes are great for professional or student use. Individual shapes are numbered.

### 6" Boxwood Tools

NUMBER	TOOL	NUMBER	TOOL
210101	1	210120	20
210102	2	210121	21
210103	3	210122	22
210104	4	210123	23
210105	5	210124	24
210106	6	210125	25
210107	7	210126	26
210108	8	210127	27
210109	9	210128	28
210110	10	210129	29
210111	11	210130	30
210112	12	210131	31
210113	13	210132	32
210114	14	210133	33
210115	15	210134	34
210116	16	210135	35
210117	17	210136	36
210118	18	210137	37
210119	19	210138	38

### 8" Boxwood Tools

(Call for set contents.)

NUMBER 210201 THRU 210238

### Boxwood Tool Sets

NUMBER	DESCRIPTION
210139	6" Set of 10 (assorted)
210141	6" Set of 8 (assorted)
210145	6" Set of 10 (assorted)
210239	6" Set of 6 (assorted)
210240	6" Set of 12 (assorted)
210241	8" Set of 6 (assorted)
210242	8" Set of 12 (assorted)
210243	8" Set of 10 (assorted)
210246	8" Set of 38 (1 of each)

### 72 Piece Boxwood Tool

Canisters (Call for set contents.)

NUMBER	DESCRIPTION
210150	6" tools (assorted)
210250	8" tools (assorted)

### Potter's Ribs

Beautifully formed and polished boxwood tools for shaping clay while working on the wheel.

NUMBER	DESCRIPTION
210401	#1 - Oval
210402	#2 - Triangle
210403	#3 - Long narrow
210404	#4 - Rectangle
210405	#5 - Quarter oval
210395	#6 - Quarter rectangle
210396	#7 - Quarter oval
210397	#8 - Quarter oval
210398	#9 - Quarter oval
210399	#10 - Quarter oval
210400	#11 - Quarter oval
210393	Set of 11 (1 of each #1-11)
210394	Set of 6 (1 of each #1-6)
210406	Set of 5 (1 of each #1-5)
210407	Set of 3 (1 of each #1,2,4)

# SCULPTURE & POTTERY TOOLS

## A. 9" Ribbon Wire Tools

Flat, ribbon-like steel is used to form the cutting heads of these tools. These double-edged modeling tools provide a wide variety of shapes for light cutting and trimming of clay, greenware, plaster, etc. Wooden handles with metal ferrules.

NUMBER	TOOL	NUMBER	TOOL
210431	1	210434	4
210432	2	210435	5
210433	3		
210436	Set of 5 (double-end tools)		
210507	Set of 6 (single-end tools)		

(Call for set contents.)



## B. Wire End Tools

These double-ended modeling tools come in an assortment of useful shapes to meet a variety of clay modeling requirements.

NUMBER	TOOL	NUMBER	TOOL
210421	1	210424	4
210422	2	210425	5
210423	3	210426	6
210437	Set of 6 (double-end tools)		
210508	Set of 6 (single-end tools)		
210564	Canister of 60 (10 each)		

(Call for set contents.)

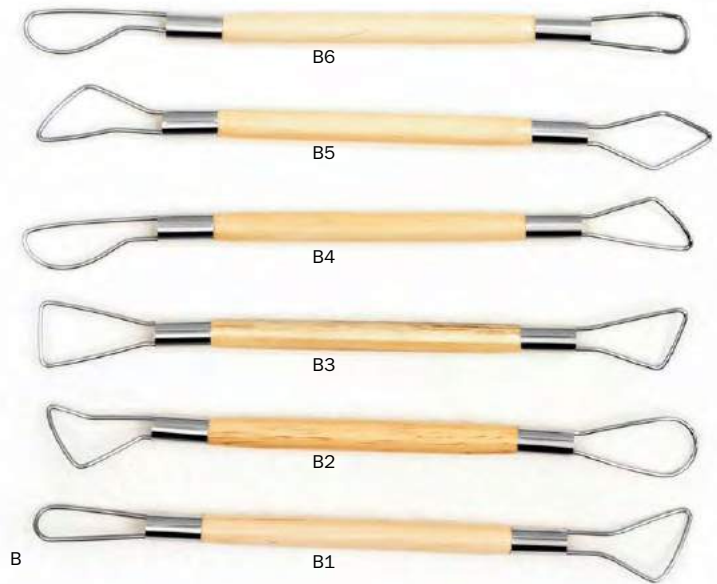

## C. Large Pottery Loops

Spring-tempered steel shapes set in thick, tapered handles. Use them to trim or refine the shape and control the wall thickness on greenware. The tools are approximately 5" long.

NUMBER	DESCRIPTION
210500	#1 - 1/2" triangle
210501	#2 - 3/4" circle
210502	#3 - 1" circle
210503	#4 - 1/2" tear drop
210504	#5 - 1-3/4" loop
210505	#6 - 1-1/4" triangle
210506	#7 - 1" triangle
210515	#8 - 1-3/4" triangle

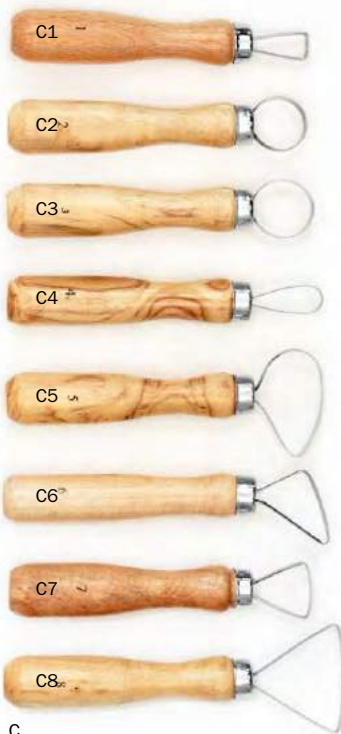

## D. Modeling Tool Canister Set

This canister of tools is a great starter kit for artists of all levels. It contains a variety of ribbon wire tools, which are used for cutting and trimming clay, greenware, or plaster. It also contains a variety of wire end tools and clean-up tools, which are useful for adding detail and smoothing edges. Includes 69 pieces total. (Call for set contents.)

NUMBER 210563



# WATERCOLOR PAPER

Watercolor is considered a very traditional painting technique. In traditional transparent watercolor, the whitest point of your painting will be the hue of the paper itself. To acquire the desired brightness and spontaneity that characterizes traditional watercolor, experiment with different types of paper.



SURFACES

175

## A. ~~Quiller Watercolor Block~~

~~100% Cotton, 12 Sheets  
Acid Free~~

~~Water media master, Stephen Quiller, relies on consistent qualities from every product he uses. That's why he uses Jack Richeson's mould made, 100% cotton fiber paper.~~

NUMBER	SIZE	WEIGHT/TYPE
<del>100520</del>	<del>11" x 15"</del>	<del>140 lb. CP</del>
<del>100521</del>	<del>15" x 22"</del>	<del>140 lb. CP</del>

## B. Watercolor Postcards 135lb. Cold Press, Acid Free

Quality 135lb. alpha cellulose paper, these cards are perfect for artists to send off a hand painted greeting. Available in a 4" x 6" 15 sheet pad.

NUMBER 100205

## C. Watercolor Pads

### 135lb. Cold Press, Acid Free

High-performing alpha cellulose paper. Acid free. Available in 12 sheet pads.

NUMBER	SIZE	CARTON QTY
100260	6" x 9"	48 / carton
100261	9" x 12"	24 / carton
100262	11" x 15"	12 / carton
100263	12" x 16"	12 / carton
100264	15" x 20"	12 / carton
100265	18" x 24"	12 / carton

## D. Student Watercolor Pads

Available in 25 sheet pads. Lightweight paper suitable for children.

NUMBER	SIZE	CARTON QTY
100256	9" x 12"	24 / carton
100257	12" x 18"	12 / carton
100258	18" x 24"	12 / carton

## E. JRC 135# Watercolor Paper

Packs of 135# cold press watercolor paper. Instructors and painters will love these convenient sizes at a great introductory price.

- Acid free, alpha cellulose

NUMBER	DESCRIPTION
100866	11" x 15" 25 sheets
100867	6" x 9" 50 sheets
100868	9" x 12" 50 sheets
100869	12" x 18" 50 sheets

\*Must purchase in increments of 10 packs  
See bulk packs of this paper on page 179.

## F. JRC 88# Watercolor Paper

- Acid free, alpha cellulose

NUMBER	DESCRIPTION
100857	6" x 9" 50 sheets
100858	9" x 12" 50 sheets
100859	12" x 18" 50 sheets

See bulk packs of this paper on page 179.

# DRAWING & SKETCH PADS

Jack Richeson drawing pads are brilliant white, acid free, and have a surface that was made for pencil, charcoal, and pastels. This series of pads features a plastic spiral binding to prevent getting caught in your sweater or fighting with bent metal spirals. They lay flat and open and close with ease.

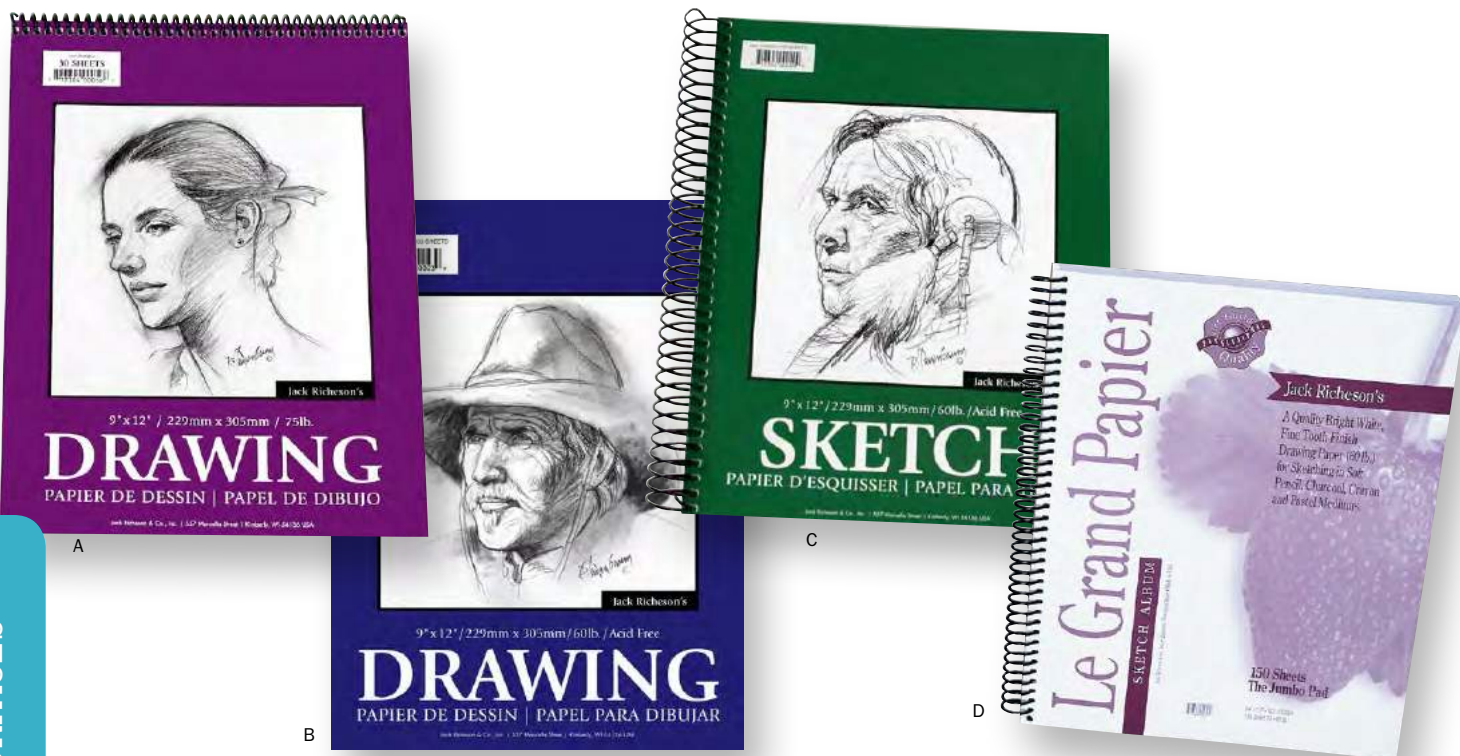

SURFACES

176

www.richesonart.com 1.800.233.2404

## A. Top Spiral Bound Drawing Pads 75lb, Acid Free

Available in 30 and 70 sheet pads.

### 30 sheets per pad

NUMBER	SIZE	CARTON QTY
100240	4" x 6"	24 / carton
100241	5" x 8"	24 / carton
100242	6" x 9"	24 / carton
100243	8" x 10"	12 / carton
100244	9" x 12"	12 / carton
100245	11" x 14"	12 / carton
100246	12" x 18"	12 / carton
100247	14" x 17"	12 / carton
100248	18" x 24"	12 / carton

### 70 sheets per pad

NUMBER	SIZE	CARTON QTY
100044	9" x 12"	12 / carton
100045	11" x 14"	6 / carton
100048	18" x 24"	6 / carton

## B. Tape Bound Drawing Pads 60lb, Acid Free

Available in 100 sheet pads.

NUMBER	SIZE	CARTON QTY
100224	9" x 12"	12 / carton
100225	12" x 18"	12 / carton
100226	14" x 17"	12 / carton
100227	18" x 24"	6 / carton

## C. Side Spiral Bound Sketch Pads 60lb, Acid Free

Available in 100 sheet pads.

NUMBER	SIZE	CARTON QTY
100250	5-1/2" x 8-1/2"	12 / carton
100251	8-1/2" x 11"	12 / carton
100252	9" x 12"	12 / carton
100253	11" x 14"	12 / carton
100254	14" x 17"	12 / carton

## D. Spiral Bound Le Grand Papier 60lb, Acid Free

These high quality drawing pads are available in 150 sheet pads in four different cover designs. (Randomly selected.)

NUMBER	SIZE	CARTON QTY
100050	5-1/2" x 8-1/2"	8 / carton
100051	8-1/2" x 11"	8 / carton
100053	11" x 14"	8 / carton

## E. Eco Sketch Journals 60lb Acid Free, 100 Sheets

A plain covered pad that longs to be "dressed up" by its new owner or simply left as is. These drawing pads are spiral bound with sturdy blank chipboard covers. They are the finest quality 60lb. paper without the expense of a printed cover. Ideal for charcoal, pencil, pastels, or scrapbooking.

NUMBER	SIZE	CARTON QTY
100375	8-1/2" x 11"	10 / carton
100376	6" x 6"	10 / carton
100377	5-1/2" x 8-1/2"	40 / carton





# NEWSPRINT & TRACING PAPER

Perfect for all your sketching needs!



A



B

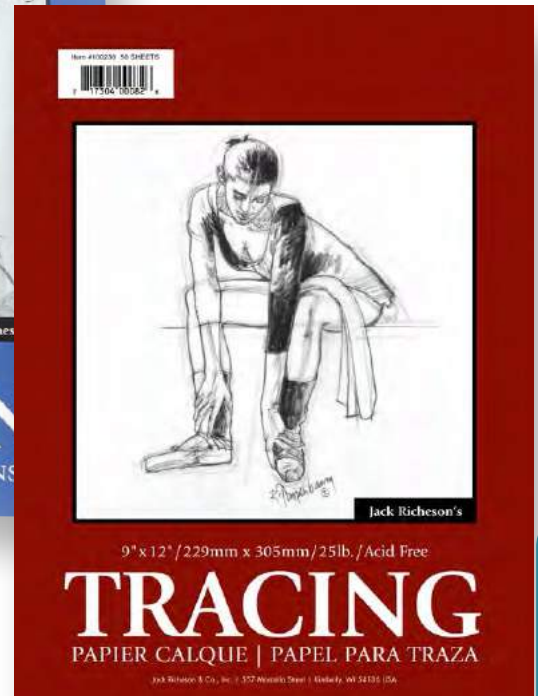

C

## Richeson Newsprint Pads

A school favorite for drawing with pencil, charcoal, pastels, crayons and markers. Our Newsprint Pads have a heavy chipboard backing for pad support while working at an easel. Dealers: to protect against damage in shipping, order pads in carton quantities.

### A. ~~Smooth Surface Newsprint~~ 50 sheets per pad

NUMBER	SIZE	CARTON QTY
100302	18" x 24"	20 / carton

### ~~100 sheets per pad~~

NUMBER	SIZE	CARTON QTY
100304	9" x 12"	20 / carton
100305	12" x 18"	24 / carton
100307	18" x 24"	12 / carton

## Private Label Pad Covers

Jack Richeson & Co. is able to design a pad cover that is exclusively yours! Call the sales department for more information at 1-800-233-2404.

### B. Rough Surface Newsprint 50 sheets per pad

NUMBER	SIZE	CARTON QTY
100216	9" x 12"	24 / carton
100217	12" x 18"	12 / carton
100219	18" x 24"	12 / carton
100220	24" x 36"	12 / carton

### 100 sheets per pad

NUMBER	SIZE	CARTON QTY
100210	9" x 12"	12 / carton
100211	12" x 18"	8 / carton
100213	18" x 24"	6 / carton

### C. Tracing Pads 25lb. Acid Free

This is an extremely transparent, very durable tracing paper. Excellent for doing overlays, sketches and drawings in the classroom or studio. Perfect for use with pencil, crayon, pen, or marker. 50 sheets per pad.

NUMBER	SIZE	CARTON QTY
100230	9" x 12"	36 / carton
100231	11" x 14"	24 / carton
100232	14" x 17"	44 / carton
100233	12" x 18"	24 / carton
100234	19" x 24"	12 / carton

### D. 19x25 Laid White Charcoal Paper - 70lb - Bulk Packed

Beautiful paper, perfect for charcoal drawings. Charcoal side has beautiful tooth. Bulk packaged, perfect for schools and universities.

NUMBER 100490-100 (100 PACK)



# DISPOSABLE PALETTES

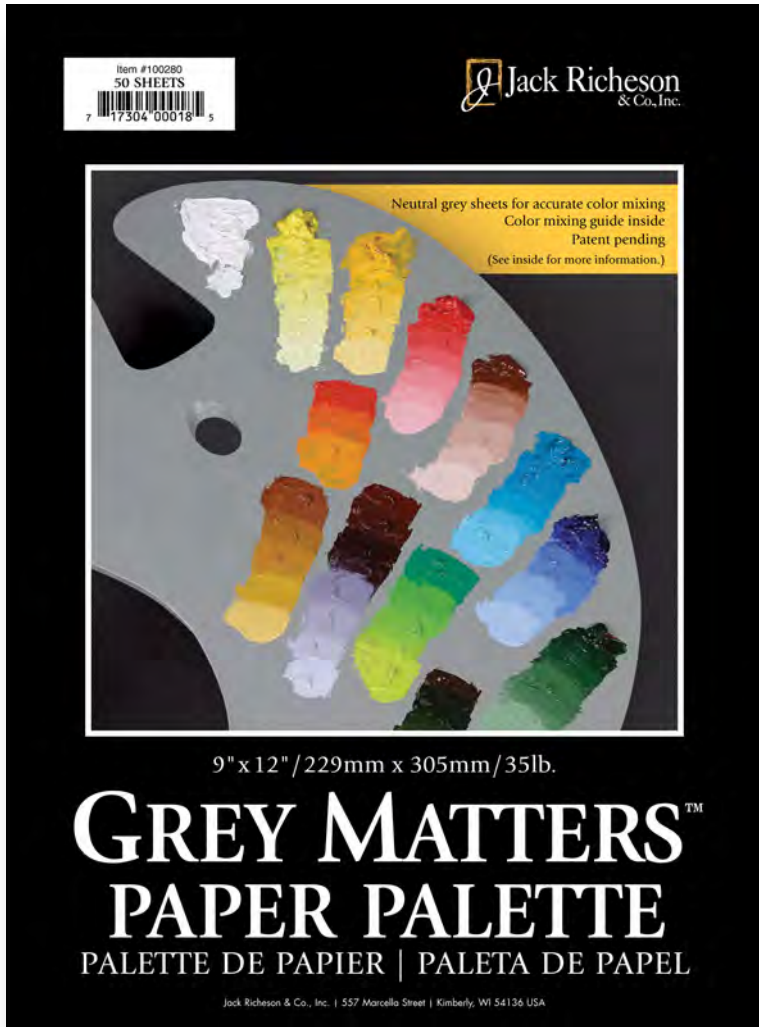

The inside cover of the Grey Matters Palette serves as a great painting tool featuring comments and suggestions by professional water media painter Stephen Quiller. [www.quillergallery.com](http://www.quillergallery.com)

## Grey Matters™ Paper Palettes

If you use a toned canvas, why not mix the paint you are using on the same color surface that you are painting on? See what your color will look like before you apply it to your masterpiece!

- Acid free palette paper
- Smooth mixing surface
- Toned in a neutral grey
- Provides a neutral backdrop on which to view colors
- When using a toned painting support, mixed colors appear on the palette as they will in the painting

### 30 and 50 Sheet Pads

NUMBER	SIZE	CARTON QTY
100279	30shts 6" x 9"	72 / carton
100280	50shts 9" x 12"	30 / carton
100281	50shts 12" x 16"	20 / carton
100289	30shts 16" x 20"	24 / carton

## Disposable Palette Pads

Available in two sizes, Jack Richeson Disposable Paper Palettes are constructed with a specially coated, heavy 41 lb., low density, white paper that is resistant to all types of paint and won't bleed through. Tear off one sheet at a time and throw away the mess!

### 50 sheets per pad

NUMBER	SIZE	CARTON QTY
101040	9" x 12"	30 / carton
101041	12" x 18"	15 / carton

*Great products for plain air painting!*



# BULK PAPER

## 60# Drawing Paper

NUMBER	DIMENSIONS	SHEETS	CARTON SIZE	CARTON WT.
100800	9" x 12"	1,400	9.5" x 12.5" x 8.5"	20 lbs
100801	11" x 14"	800	11.5" x 14.5" x 5"	16 lbs
100802	12" x 18"	800	12.5" x 18.5" x 5"	23 lbs
100803	18" x 24"	700	18.5" x 24.5" x 4.5"	41 lbs

## 75# Drawing Paper

NUMBER	DIMENSIONS	SHEETS	CARTON SIZE	CARTON WT.
100810	9" x 12"	1,000	9.5" x 12.5" x 8.5"	19.5 lbs
100811	11" x 14"	575	11.5" x 14.5" x 5"	15.5 lbs
100812	12" x 18"	575	12.5" x 18.5" x 5"	22 lbs
100813	18" x 24"	500	18.5" x 24.5" x 4.5"	39 lbs

## 90# Drawing Paper

NUMBER	DIMENSIONS	SHEETS	CARTON SIZE	CARTON WT.
100820	9" x 12"	800	9.5" x 12.5" x 8.5"	19 lbs
100821	11" x 14"	475	11.5" x 14.5" x 5"	15 lbs
100822	12" x 18"	475	12.5" x 18.5" x 5"	22 lbs
100823	18" x 24"	400	18.5" x 24.5" x 4.5"	37 lbs

## 35# Newsprint

NUMBER	DIMENSIONS	SHEETS	CARTON SIZE	CARTON WT.
100830	9" x 12"	1,600	9.5" x 12.5" x 8.5"	14 lbs
100831	11" x 14"	900	11.5" x 14.5" x 5"	11.5 lbs
100832	12" x 18"	900	12.5" x 18.5" x 5"	16 lbs
100833	18" x 24"	1,000	18.5" x 24.5" x 5.5"	35.5 lbs

## 25# Tracing Paper

NUMBER	DIMENSIONS	SHEETS	CARTON SIZE	CARTON WT.
100840	9" x 12"	3,800	9.5" x 12.5" x 8.5"	25 lbs
100841	11" x 14"	2,100	11.5" x 14.5" x 5"	21 lbs
100842	12" x 18"	2,100	12.5" x 18.5" x 5"	28 lbs
100843	18" x 24"	1,850	18.5" x 24.5" x 4.5"	50 lbs

## 88# Watercolor

NUMBER	DIMENSIONS	SHEETS	CARTON SIZE	CARTON WT.
100850	9" x 12"	625	9.5" x 12.5" x 8.5"	19 lbs
100851	11" x 14"	350	11.5" x 14.5" x 5"	16 lbs
100852	12" x 18"	350	12.5" x 18.5" x 5"	21 lbs
100853	18" x 24"	300	18.5" x 24.5" x 4.5"	37 lbs
100855	22.5" x 30.5"	100	23" x 31" x 1.75"	18 lbs

## 135# Watercolor

NUMBER	DIMENSIONS	SHEETS	CARTON SIZE	CARTON WT.
100860	9" x 12"	425	9.5" x 12.5" x 8.5"	19 lbs
100861	11" x 14"	250	11.5" x 14.5" x 5"	16 lbs
100862	12" x 18"	250	12.5" x 18.5" x 5"	21 lbs
100863	18" x 24"	200	18.5" x 24.5" x 4.5"	37 lbs
100865	22.5" x 30.5"	100	23" x 31" x 2.5"	28 lbs

## 41# Palette Paper

NUMBER	DIMENSIONS	SHEETS	CARTON SIZE	CARTON WT.
100870	9" x 12"	2,500	9.5" x 12.5" x 8.5"	26 lbs
100871	11" x 14"	1,400	11.5" x 14.5" x 5"	21 lbs
100872	12" x 18"	1,400	12.5" x 18.5" x 5"	30 lbs
100873	18" x 24"	1,250	18.5" x 24.5" x 4.5"	54 lbs



## All-Purpose Chipboard

- Perfect for craft projects
- Book-making in schools
- Uncoated board
- Great for mounting & backings
- Multi-purpose smooth

### 1.5mm Packs of 6

NUMBER	SIZE
788001	8-1/2" x 11"
788002	12" x 18"
788003	18" x 24"
788004	24" x 36"

### 2.2mm Packs of 6

NUMBER	SIZE
788007	8-1/2" x 11"
788008	12" x 18"
788009	18" x 24"
788010	24" x 36"

# SPECIALTY PAPERS & CRAFT KITS

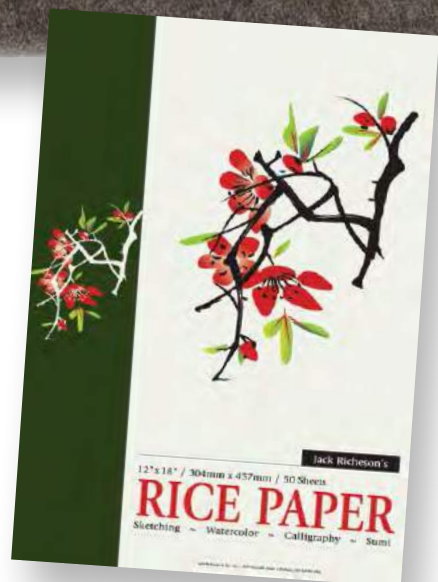

SURFACES

180

## Richeson Transfer Paper Rolls

- 24" x 24"
- No waste, no bleed
- Clean, clear tracings
- Great for multiple uses
- Smudge proof
- Erasable

NUMBER 101050

## Richeson Butcher Paper Rolls

- 30" x 50'
- Excellent for use with markers, acrylics, gouache, finger paint
- Use as a paper palette
- Will not bleed through
- Food safe

NUMBER 1010448 (WHITE)  
NUMBER 1010450 (BLACK)

## Richeson Rice Paper

Crafters enjoy working with rice paper because of its distinct texture and slight translucent appearance. Great for sketching, calligraphy, watercolor and sumi, this paper is available in a convenient 12" x 18" pad or 15" x 50ft roll!

## Richeson Rice Paper Rolls

- Acid free
- Continuous 15" x 50ft roll
- Sketching
- Calligraphy
- Watercolor
- Sumi

NUMBER 101065

## Richeson Rice Paper Pad

- Acid free
- 12" x 18"
- 50 Sheets
- Sketching
- Calligraphy
- Watercolor
- Sumi

NUMBER 101070

## Book Making Class Packs 6" x 6" (Makes 12 books)

Contains:

- 24 pre-punched 6" x 6" chipboard covers
- 600 sheets of 6" x 6" pre-punched 80# paper
- 12 - 18mm black - 6" binding coils

NUMBER 100466

## 6" x 9" (Makes 30 books)

Contains:

- 60 Pre-punched 6" x 9" chipboard covers
- 1000 Sheets of 6" x 9" pre-punched 80# paper
- 30 - 18mm black - 9" binding coils

NUMBER 100469



# RICHESON TONED HARDBOARD

With beautifully beveled edges, these warp-resistant tempered panels are covered with a high-quality toned gesso and are produced with a double coat waterfall system for a perfect lightly toothy surface. Perfect for portraitists, they are a time and energy-saver, ideal for both pros and students. Perfect for use with oils, alkyds, acrylics, caseins, and other water-based paints.



Painting detail by Clay Roberts

SURFACES

181

These boards were developed upon request from numerous professionals in the art materials industry.

Because most instructors start by advising students to tone their boards with either umber wash or mid-tone grey, these toned boards by JRC are the answer to that need.

Richeson has enjoyed overwhelming success with the 1/8" Richeson white gesso panels and see the same success with these toned boards.

The double-coat waterfall system yields a controlled, even application of acrylic gesso resulting in the perfectly toothy surface. Tempered High Density Fiberboard (HDF) base offers optimal strength and durability.

## Mid-Tone Grey Toned Gessoed 1/8" Hardboard

NUMBER	NUMBER
1610404	4" x 4"
1610505	5" x 5"
1610507	5" x 7"
1610606	6" x 6"
1610609	6" x 9"
1610612	6" x 12"
1610808	8" x 8"
1610810	8" x 10"
1610912	9" x 12"
1611010	10" x 10"
1611114	11" x 14"
1611212	12" x 12"
1611216	12" x 16"
1611224	12" x 24"
1611418	14" x 18"
1611620	16" x 20"
1611824	18" x 24"
1611836	18" x 36"
1612436	24" x 36"

## Umbur Wash Toned Gessoed 1/8" Hardboard

NUMBER	SIZE
1710404	4" x 4"
1710505	5" x 5"
1710507	5" x 7"
1710606	6" x 6"
1710609	6" x 9"
1710612	6" x 12"
1710808	8" x 8"
1710810	8" x 10"
1710912	9" x 12"
1711010	10" x 10"
1711114	11" x 14"
1711212	12" x 12"
1711216	12" x 16"
1711224	12" x 24"
1711418	14" x 18"
1711620	16" x 20"
1711824	18" x 24"
1711836	18" x 36"
1712436	24" x 36"

# RICHESON GESSOED HARDBOARD

The range of gesso panels on the market today range from almost glassy smooth to very textured. Jack Richeson & Co. spent two years in the development of our Gesso Panels, resulting in a strong warp-resistant tempered panel. These panels are coated with a high quality acrylic gesso using a two coat waterfall system for the perfect lightly toothy finished surface. This surface will not separate from the panel but bonds perfectly, making it the perfect panel for all painters – professional as well as students.

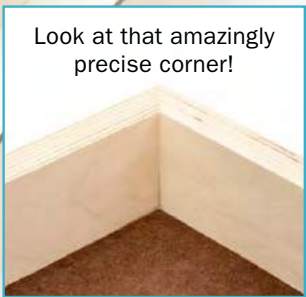

Look at that amazingly precise corner!

## Gessoed 1/8" Hardboard Panels

NUMBER	SIZE
1510404	4" x 4"
1510505	5" x 5"
1510507	5" x 7"
1510606	6" x 6"
1510609	6" x 9"
1510612	6" x 12"
1510808	8" x 8"
1510810	8" x 10"
1510912	9" x 12"
1511010	10" x 10"
1511114	11" x 14"
1511212	12" x 12"
1511216	12" x 16"
1511224	12" x 24"
1511418	14" x 18"
1511620	16" x 20"
1511824	18" x 24"
1511836	18" x 36"
1512436	24" x 36"

*Professional tempered hardboard coated with high quality acrylic gesso!*

## 3/4" Cradled Gessoed Hardboard

NUMBER	SIZE
1520404	4" x 4"
1520606	6" x 6"
1520612	6" x 12"
1520808	8" x 8"
1520810	8" x 10"
1520912	9" x 12"
1521010	10" x 10"
1521114	11" x 14"
1521212	12" x 12"
1521216	12" x 16"
1521620	16" x 20"
1521824	18" x 24"

## 2" Cradled Gessoed Hardboard

NUMBER	SIZE
1530404	4" x 4"
1530606	6" x 6"
1530612	6" x 12"
1530808	8" x 8"
1530810	8" x 10"
1530912	9" x 12"
1531010	10" x 10"
1531114	11" x 14"
1531212	12" x 12"
1531216	12" x 16"
1531620	16" x 20"
1531824	18" x 24"



Sample with textured finish.

Sample with collage art.

## Unfinished Birch Panel – 12" x 12"

A smoothly sanded unfinished birch panel with a 3/4" cradle. Perfect for mixed media work, oils or home décor. One size only. Must order in quantities of 8. Bulk packed. Ships un-shrinkwrapped.

**NUMBER 1821212**

# RICHESON HARDBOARD



## Untempered Hardboard Panels

1/8" thick medium-density panels are perfect as a painting surface, mixing palette or for taping down watercolor paper. Value-priced panels make this product especially attractive for use by university and art college students.

NUMBER	SIZE
696512	5" x 7"
696509	6" x 6"
696516	7" x 17"
696513	8" x 10"
696500	8" x 11"
696501	9" x 12"
696502	10" x 14"
696515	10-1/2" x 10-1/2"
696510	11" x 14"
696518	12" x 12"
696514	12" x 16"
696503	12" x 18"
696504	14" x 18"
696505	16" x 20"
696506	18" x 24"
696511	20" x 24"
696507	24" x 30"
696508	24" x 36"

## Tempered Hardboard Panels

1/8" thick tempered panels are perfect for professionals as well as artists at all levels. Manufactured in the USA from high-density smooth hardboard using solid fiber core, and tempered in the traditional method. This eliminates any residue on the panel and results in a strong panel with low tendency for warping.

NUMBER	SIZE
1500404	4" x 4"
1500505	5" x 5"
1500507	5" x 7"
1500606	6" x 6"
1500609	6" x 9"
1500612	6" x 12"
1500808	8" x 8"
1500810	8" x 10"
1500912	9" x 12"
1501010	10" x 10"
1501114	11" x 14"
1501212	12" x 12"
1501216	12" x 16"
1501224	12" x 24"
1501418	14" x 18"
1501620	16" x 20"
1501824	18" x 24"
1501836	18" x 36"
1502436	24" x 36"

## Hardboard: Tempered versus Untempered

For centuries, artists have been painting on a variety of surfaces from stone to wood to canvas – the possibilities are unending!

Today, artists commonly use a surface we know as hardboard as a substrate for their work. This material has sparked unending debates on the value of **tempered vs untempered** hardboard for use by artists.

Before entering into the discussion you must first understand... **What is Hardboard? What is Tempered Hardboard?**

Hardboard, which is also called high-density fiberboard, is a type of engineered wood. It is similar to particle board in the way it is manufactured, but it is much denser, stronger and harder. Unlike particle board, hardboard will not split or crack.

Hardboard can be manufactured to be either tempered or untempered. Tempered hardboard is hardboard that is thinly coated with linseed oil and then baked. This makes it harder, more rigid, more water-resistant and increases its tensile strength.

*The Manual of Painting Materials and Painting Techniques* by Mark Gottsegen states that both tempered and untempered can be used for painting purposes. At Richeson, we offer both tempered and untempered. Untempered is a lower cost option, attractive especially at the university level and for value-priced finished pieces. Many professionals lean towards tempered panels as their preferred choice. The belief is that the tempering process results in a stronger panel with less warping. With this in mind, at Richeson we have opted to use the tempered hardboard as the material for our professional gessoed boards, offering the highest quality.

# ~~RICHESON PREMIUM PASTEL SURFACES~~

~~Jack Richeson & Co. has created a premium pastel surface available on two different substrates: Gator board and heavyweight paper. The texture of these surfaces is like no other. With an exquisite, "toothy" finish, pastels can be applied with ease as the surface grabs and holds the pigment, layer after layer.~~



Painting by Natasha Isenhour  
www.natashaisenhour.com

## **~~Benefits to Richeson Premium Pastel Surfaces:~~**

- ~~• Color and "grit" is integrated directly into the substrate~~
- ~~• No irritating separation of "grit" with rubbing or washing of the surface~~
- ~~• Surface holds up to water washes as well as rinsing the surface to restart. (When using Gator, we recommend taping the edges.)~~
- ~~• Lightweight Gator is easy to transport~~
- ~~• No taping! No delamination!~~
- ~~• No separate backboard required~~

## **~~Benefits of using Richeson Pastel Surface on Gator Foam™:~~**

~~Painting outdoors presents special challenges for pastel artists specifically related to the painting surface.~~

- ~~• Taping paper to a support can be difficult and time-consuming~~
- ~~• Masking tape, paper and back board are cumbersome to bring to the site with other equipment~~
- ~~• Save money by using Richeson Premium Gator by eliminating the cost of mounting~~

~~Richeson Premium Pastel Surfaces makes these issues "go away"!~~

## **~~Benefits of using Richeson Premium Pastel Paper Surfaces:~~**

- ~~• You are not confined to standard paper sizes~~
- ~~• Lightweight~~
- ~~• Affordable~~
- ~~• Available in packs of 10~~



# ~~RICHESON PREMIUM PASTEL SURFACES~~

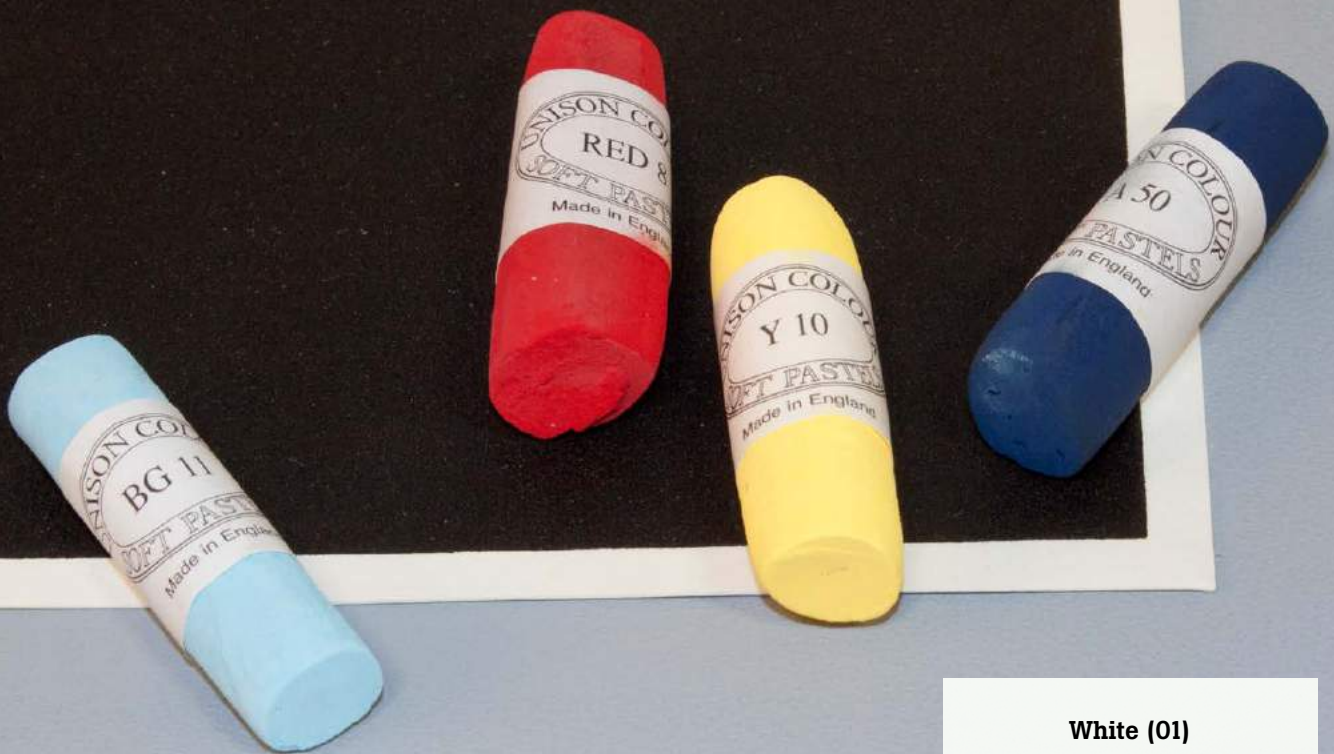

White (01)

Black (02)

Clay (05)

Sandstone (06)

Light Umber (07)

Marble (08)

Storm (11)

Shale (13)

Terra Cotta (24)

SURFACES

185

When ordering the pastel surfaces, please use the following numbering system: 4 digit prefix to designate product and size + 2 digit color designation. **Example: to order a 9"x12" Storm pastel Gator Foam, the item number is 103211.**

## ~~Pastel Gator Board~~

NUMBER	SIZE
1030	5" x 7"
1031	8" x 10"
1032	9" x 12"
1033	11" x 14"
1034	12" x 16"
1036	16" x 20"
1037	18" x 24"

## ~~Pastel Paper (10shs/plk)~~

NUMBER	SIZE
1050	5" x 7"
1051	8" x 10"
1052	9" x 12"
1053	11" x 14"
1054	12" x 16"
1056	16" x 20"
1057	18" x 24"

# CARAVAGGIO CANVAS ROLLS



## FINEST CANVAS ROLLS FROM ITALY

Named for the famous Italian artist Caravaggio of the late 1500s, Caravaggio Canvas is some of the finest available in the world. Milled in Verese, Italy for over 30 years, Caravaggio Canvas is Europe's top primed canvas. Using a state-of-the-art priming method, this canvas delivers optimum consistency. Known for an amazing range of textiles and textures, Caravaggio canvas is available in:

### Raw Linen Rolls

- Extra Fine, Fine, Medium and Rough textures

### Acrylic Primed Rolls

- Linen, Cotton, Jute, Polycotton, Cotton Linen and 100% Polyester
- Extra Fine, Fine, Universal Grain, Rough and Extra Rough

### Oil Primed Linen Rolls

- Extra Fine, Fine, Medium



### Cotton 75%, Polyester 25% Medium Texture

NUMBER	SIZE	PRIMING
30501160	63 x 190	White
30501210	83 x 190	White
31501160	63 x 390	White
31501210	83 x 390	White



### Cotton 100% Medium Texture

NUMBER	SIZE	PRIMING
30502210	83 x 190	White
31502210	83 x 390	White



### Cotton 100% Extra Fine Texture

NUMBER	SIZE	PRIMING
30503210	83 x 190	White
31503210	83 x 390	White



### Polyester 100%, Extra Fine Texture

NUMBER	SIZE	PRIMING
30504210	83 x 190	White
31504210	83 x 390	White



### Polyester 67%, Cotton 33% Fine Texture, 11oz.

NUMBER	SIZE	PRIMING
30507210	83 x 190	White
31507210	83 x 390	White

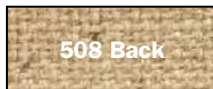

### Jute 100%, Extra Rough Texture

NUMBER	SIZE	PRIMING
30 <b>508</b> 210	83 x 190	White
31 <b>508</b> 210	83 x 390	White

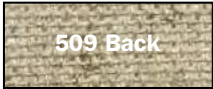

### Linen 100%, Medium Texture

NUMBER	SIZE	PRIMING
30 <b>509</b> 155	61 x 190	White
30 <b>509</b> 210	83 x 190	White
31 <b>509</b> 155	61 x 390	White
31 <b>509</b> 210	83 x 390	White
30 <b>509</b> GG155	61 x 190	Raw
30 <b>509</b> GG215	84 x 190	Raw
31 <b>509</b> GG155	61 x 390	Raw
31 <b>509</b> GG215	84 x 390	Raw
<del>30<b>509</b>OP215</del>	<del>84 x 190</del>	<del>Oil</del>
31 <b>509</b> OP205	84 x 390	Oil



### Linen 100%, Medium Texture

NUMBER	SIZE	PRIMING
<del>30<b>510</b>GG215</del>	<del>84 x 190</del>	<del>Raw</del>
<del>31<b>510</b>GG215</del>	<del>84 x 390</del>	<del>Raw</del>



### Linen 100%, Fine Texture

NUMBER	SIZE	PRIMING
30 <b>511</b> 210	83 x 190	White
31 <b>511</b> 210	83 x 390	White
30 <b>511</b> F210	83 x 190	Clear
31 <b>511</b> F210	83 x 390	Clear
30 <b>511</b> OP210	83 x 190	Oil
31 <b>511</b> OP210	83 x 390	Oil

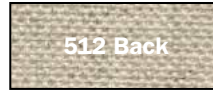

### Linen 100%, Medium Texture

NUMBER	SIZE	PRIMING
30 <b>512</b> 210	83 x 190	White
31 <b>512</b> 210	83 x 390	White
30 <b>512</b> GG215	84 x 190	Raw
31 <b>512</b> GG215	84 x 390	Raw



### Linen 100%, Extra Fine Texture

NUMBER	SIZE	PRIMING
30 <b>514</b> 210	83 x 190	White
31 <b>514</b> 210	83 x 390	White
<del>30<b>514</b>F210</del>	<del>83 x 190</del>	<del>Clear</del>
31 <b>514</b> F210	83 x 390	Clear
30 <b>514</b> OP210	83 x 190	Oil
<del>31<b>514</b>OP210</del>	<del>83 x 390</del>	<del>Oil</del>

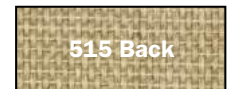

### Cotton 100%, Rough Texture

NUMBER	SIZE	PRIMING
30 <b>515</b> 210	83 x 190	White
31 <b>515</b> 210	83 x 390	White

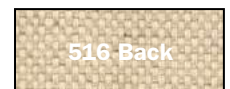

### Linen 60%, Cotton 40% Rough Texture

NUMBER	SIZE	PRIMING
30 <b>516</b> 210	83 x 190	White
31 <b>516</b> 210	83 x 390	White

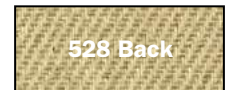

### Cotton 100%, Fine Texture

NUMBER	SIZE	PRIMING
30 <b>528</b> 210	83 x 190	White
31 <b>528</b> 210	83 x 390	White

NUMBER	DOUBLE WHITE PRIMED SINGLE CLEAR PRIMED OIL PRIMED RAW UNPRIMED	DESCRIPTION	TEXTURE	UNPRIMED GSM WT.	UNPRIMED OZ./METER	UNPRIMED OZ./YARD	PRIMED GSM WT.	PRIMED OZ./METER	PRIMED OZ./YARD	WEAVE	SIZES AVAILABLE (approximate in inches)
501	•	Cotton 75%, Polyester 25%	Medium	210	7	6	330	12	10	S	63x190, 63x390, 83x190, 83x390
502	•	Cotton 100%	Medium	220	8	6	310	11	9	D	83x190, 83x390
503	•	Cotton 100%	Extra Fine	135	5	4	230	8	7	S	83x190, 83x390
504	•	Polyester 100%	Extra Fine	125	4	4	220	8	6.5	S	83x190, 83x390
507	•	Polyester 67%, Cotton 33%	Fine	210	7	6	310	11	9	S	83x190, 83x390
508	•	Jute 100%	Extra Rough	300	10.5	9	500	18	15	S	83x190, 83x390
509	•	Linen 100%	Medium	280	10	8	470	16.5	14	S	61x190, 61x390, 83x190, 83x390 84x190, 84x390
510	•	Linen 100%	Medium	240	8	7	-	-	-	S	84x190, 84x390
511	•	Linen 100%	Fine	220	8	6	380	13	11	S	83x190, 83x390
512	•	Linen 100%	Medium	280	10	8	420	15	12	S	83x190, 83x390 84x190, 84x390
514	•	Linen 100%	Extra Fine	220	8	6	310	11	9	S	83x190, 83x390
515	•	Cotton 100%	Rough	245	9	7	310	11	9	D	83x190, 83x390
516	•	Linen 60%, Cotton 40%	Rough	280	10	8	420	15	12	D	83x190, 83x390
528	•	Cotton 100%	Fine	340	12	10	400	14	12	*	83x190, 83x390

# BEST STRETCHER BAR DISPLAYS

## Why BEST bars?

Jack Richeson & Co. offers the finest stretcher bars. We are dedicated to ensuring you receive a consistent, quality product that is always in stock with on-time shipments and superior customer service.

- Museum-quality bars
- Made from only the finest raw materials
- Bars must be free from knots and completely straight
- Heavy-Duty and Medium-Duty bars are designed so that the canvas is 1/2" from the bar. Lightweight has 3/8" profile
- Profile eliminates "ghosting" on the canvas
- Rounded back edges reduce surface friction, allowing for a smoother, tighter draw of the canvas
- Standard bars are cut 1/8" short to comply with industry standard

### Ordering Custom Bars

- Order stretcher bars in fractional inches.  
Example of custom size: 56" exact by 72-5/8" exact
- Allow 3 working days in factory on custom orders of 1 - 5 frames
- Allow 5 working days in factory on 6 frames and up
- Jack Richeson & Co., Inc. recommends a cross brace every 36"

When ordering cross braces, please include line drawing of layout desired as shown below.

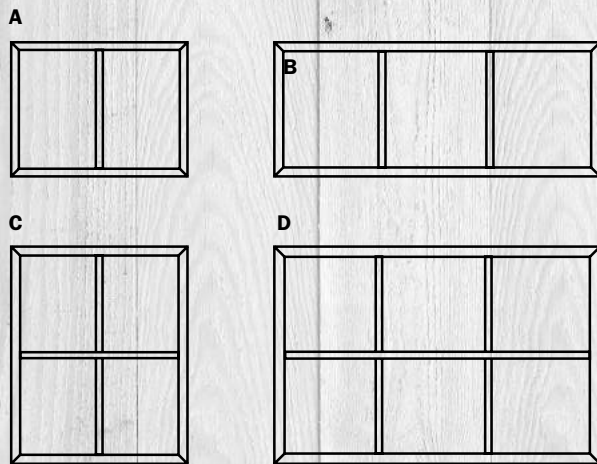

Designs with overlapping cross braces require notching of the bars at each intersection. A notching charge applies to each groove cut (Item #894501). **Contact the JRC sales department for a quote at 920.738.0744.**



### BEST Stretcher Bar Displays

- Perfect for stores and galleries with limited space
- Place two displays back to back and offer your customers more options
- Bars are held firmly in place in specially designed egg crate openings

**NUMBER 890993 LIGHT-DUTY ROLLING BAR ASSORT.**  
**NUMBER 890994 MED-DUTY ROLLING BAR ASSORT.**  
**NUMBER 890995 HEAVY-DUTY ROLLING BAR ASSORT.**  
**NUMBER 890999 PRO-BAR ROLLING BAR ASSORT.**

Please call for assortment contents.



**BEST**  
Stretcher Bars

- Finger spliced for extra stability and less warping.
- Raised edges for extra clearance under canvas.
- Precision cut angles for infallible corners.
- Made from kiln-dried pine.

**890992 GALLERY WRAP EMPTY RACK**

**890996 LDSB EMPTY RACK WITH BACKBOARD**

52" (w) x 84" (h - backboard) x 27" (d)

**890998 HDSB EMPTY RACK WITH BACKBOARD**

63" (w) x 85" (h - backboard) x 27" (d)

**890999 ALUMINUM EMPTY RACK WITH BACKBOARD**

55" (w) x 55" (h) x 27" (d)

# BEST HEAVY-DUTY STRETCHER BARS

**Museum-quality  
stretcher bars  
for the professional**

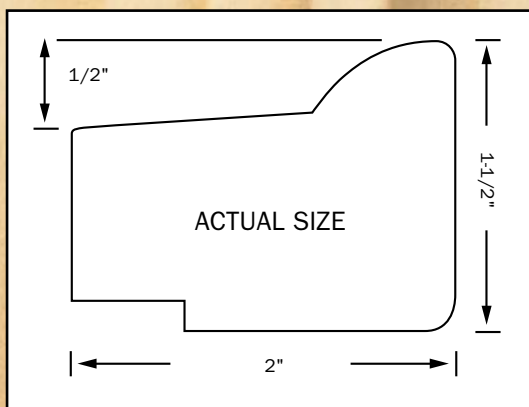

Cross-section of Heavy-duty Stretcher Bar.

*Box quantity waived for special orders!*

**NOTE: ALL SIZES NOT LISTED. LIST AVAILABLE  
UPON REQUEST. NEED FRACTIONAL SIZES?  
CALL 1-800-233-2404 FOR MORE INFORMATION.**

## Heavy-duty Stretcher Bars

The Heavy-duty bar is made of pine that has been finger-spliced – a method of bonding pieces of lumber together to form a very long, straight bar. Since the finger-spliced joints are actually stronger than the natural wood, we can now get longer, stronger and straighter bars. First designed for the construction industry, this high tech method yields better bars than ever before. *Sizes under 60" sold in quantity of 6 only.*

## Heavy-duty Bars (Box of 6)

NUMBER	SIZE	NUMBER	SIZE	NUMBER	SIZE
890001	8"	890009	24"	890027	44"
890050	9"	890010	25"	890028	46"
890002	10"	890011	26"	890029	48"
890051	11"	890012	27"	890030	50"
890003	12"	890013	28"	890031	52"
890065	13"	890014	29"	890032	54"
890004	14"	890015	30"	890033	56"
890066	15"	890016	31"	890034	58"
890005	16"	890017	32"	890035	60"
890052	17"	890018	33"	890038	72"
890006	18"	890019	34"	890041	84"
890053	19"	890020	35"	890044	96"
890007	20"	890021	36"	890046	108"
890067	21"	890023	38"	890047	120"
890008	22"	890025	40"	890228	132"
890068	23"	890026	42"	890082	144"

## Heavy-duty Cross Braces

NUMBER	SIZE	NUMBER	SIZE	NUMBER	SIZE
891001	8"	891024	39"	891055	74"
891067	9"	891025	40"	891039	76"
891002	10"	891075	41"	891058	78"
891068	11"	891026	42"	891040	80"
891003	12"	891076	43"	891060	82"
891069	13"	891027	44"	891041	84"
891004	14"	891077	45"	891062	86"
891070	15"	891028	46"	891042	88"
891005	16"	891078	47"	891056	90"
891071	17"	891029	48"	891043	92"
891006	18"	891059	49"	891106	94"
891072	19"	891030	50"	891044	96"
891007	20"	891080	51"	891096	98"
891073	21"	891031	52"	891057	100"
891008	22"	891065	53"	891045	102"
891074	23"	891032	54"	891063	104"
891009	24"	891064	55"	891112	106"
891010	25"	891033	56"	891046	108"
891011	26"	891053	57"	891048	110"
891012	27"	891034	58"	891117	112"
891013	28"	891084	59"	891119	114"
891014	29"	891035	60"	891121	116"
891015	30"	891085	61"	891123	118"
891016	31"	891050	62"	891047	120"
891017	32"	891091	63"	891148	122"
891018	33"	891036	64"	891124	124"
891019	34"	891086	65"	891126	126"
891020	35"	891037	66"	891132	128"
891021	36"	891054	68"	891136	132"
891022	37"	891052	70"	891144	140"
891023	38"	891038	72"	891092	144"

# BEST MEDIUM & LIGHT DUTY STRETCHER BARS

## Medium-duty and Light-duty Stretcher Bars

The medium-duty and light-duty bars are manufactured from pine. Light-duty bars are ideal for small paintings and can fit within the rabbets of most decorative picture frames. The Medium Duty is a nice alternative for a gallery wrap and larger paintings.

### Medium-duty Bars (Box of 12)

NUMBER	SIZE	NUMBER	SIZE	NUMBER	SIZE
890101	8"	890108	22"	890121	36"
890150	9"	890147	23"	890123	38"
890102	10"	890109	24"	890125	40"
890151	11"	890110	25"	890126	42"
890103	12"	890111	26"	890127	44"
890143	13"	890112	27"	890128	46"
890104	14"	890113	28"	890129	48"
890144	15"	890114	29"	890130	50"
890105	16"	890115	30"	890131	52"
890142	17"	890116	31"	890132	54"
890106	18"	890117	32"	890133	56"
890145	19"	890118	33"	890134	58"
890107	20"	890119	34"	890135	60"
890146	21"	890120	35"	890138	72"

\*Not available over 72"

### Medium-duty Cross Braces

NUMBER	SIZE	NUMBER	SIZE	NUMBER	SIZE
892008	8"	892028	28"	892048	48"
892009	9"	892029	29"	892049	49"
892010	10"	892030	30"	892050	50"
892011	11"	892031	31"	892051	51"
892012	12"	892032	32"	892052	52"
892013	13"	892033	33"	892053	53"
892014	14"	892034	34"	892054	54"
892015	15"	892035	35"	892055	55"
892016	16"	892036	36"	892056	56"
892017	17"	892037	37"	892057	57"
892018	18"	892038	38"	892058	58"
892019	19"	892039	39"	892060	60"
892020	20"	892040	40"	892061	61"
892021	21"	892041	41"	892062	62"
892022	22"	892042	42"	892063	63"
892023	23"	892043	43"	892064	64"
892024	24"	892044	44"	892066	66"
892025	25"	892045	45"	892068	68"
892026	26"	892046	46"	892070	70"
892027	27"	892047	47"	892072	72"

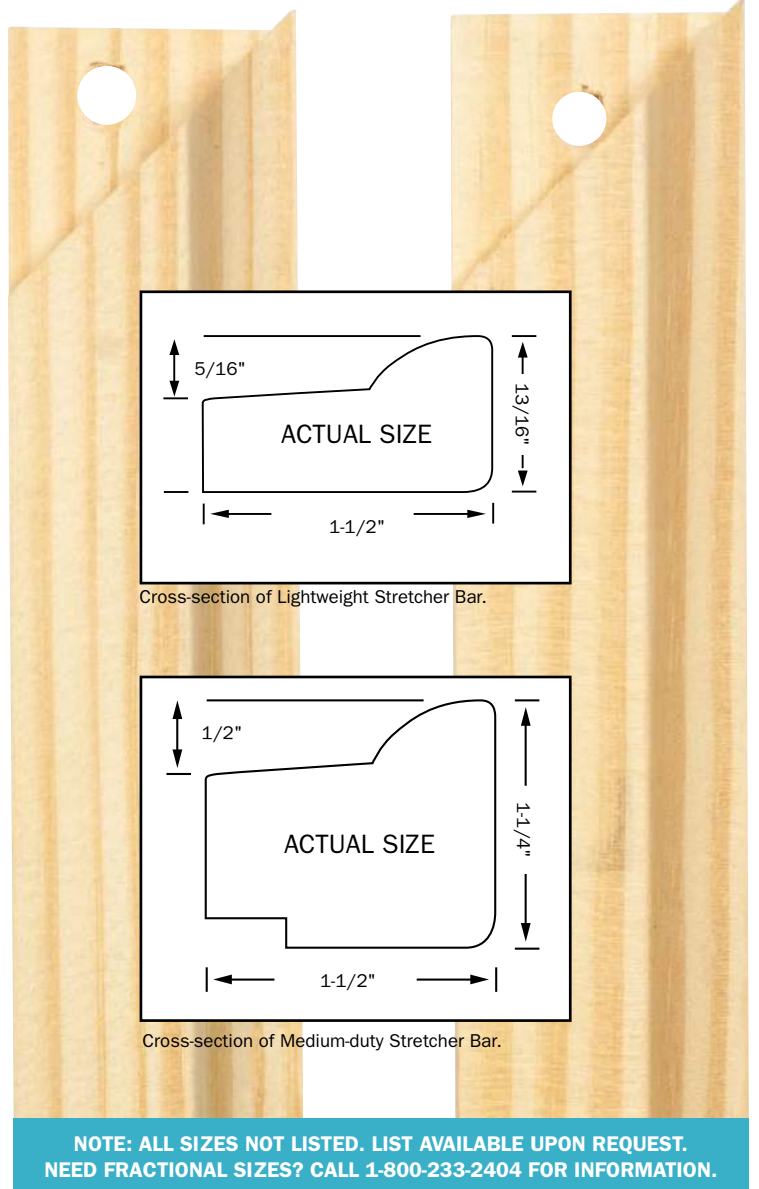

Cross-section of Lightweight Stretcher Bar.

Cross-section of Medium-duty Stretcher Bar.

**NOTE: ALL SIZES NOT LISTED. LIST AVAILABLE UPON REQUEST. NEED FRACTIONAL SIZES? CALL 1-800-233-2404 FOR INFORMATION.**

### Light-duty Bars\* (Box of 12)

NUMBER	SIZE	NUMBER	SIZE	NUMBER	SIZE
894001	8"	894015	22"	894029	36"
894002	9"	894016	23"	894031	38"
894003	10"	894017	24"	894033	40"
894004	11"	894018	25"	894035	42"
894005	12"	894019	26"	894036	44"
894006	13"	894020	27"	894037	46"
894007	14"	894021	28"	894038	48"
894008	15"	894022	29"	894039	50"
894009	16"	894023	30"	894043	52"
894010	17"	894024	31"	894040	54"
894011	18"	894025	32"	894044	56"
894012	19"	894026	33"	894041	58"
894013	20"	894027	34"	894042	60"
894014	21"	894028	35"		

\*Not available over 60"

### Light-duty Cross Braces

NUMBER	SIZE	NUMBER	SIZE	NUMBER	SIZE
897008	8"	897022	22"	897036	36"
897009	9"	897023	23"	897038	38"
897010	10"	897024	24"	897040	40"
897011	11"	897025	25"	897042	42"
897012	12"	897026	26"	897044	44"
897013	13"	897027	27"	897046	46"
897014	14"	897028	28"	897048	48"
897015	15"	897029	29"	897050	50"
897016	16"	897030	30"	897052	52"
897017	17"	897031	31"	897054	54"
897018	18"	897032	32"	897056	56"
897019	19"	897033	33"	897058	58"
897020	20"	897034	34"	897060	60"
897021	21"	897035	35"		

# BEST ALUMINUM STRETCHER BARS

## Aluminum Pro-Bar Stretcher (Box of 6) Sizes under 60" sold in quantity of 6 only.

Kiln-dried pine is connected to a specially milled 3/8" aluminum bar. Paintings will never twist, warp, bend or change due to dryness or humidity. The recycled aluminum stock provides a structural frame of total strength and stability. The pine outer bar offers a smooth, rounded edge and a solid surface for stapling. Pro-Bars start at 8" and can be cut to 144" and beyond. Must be assembled with aluminum corner inserts (item 895020-04).

NUMBER	SIZE	NUMBER	SIZE	NUMBER	SIZE	NUMBER	SIZE	NUMBER	SIZE
893002	8"	893011	18"	893021	28"	893033	40"	893041	58"
893010	9"	893024	19"	893076	29"	893035	42"	893042	60"
893003	10"	893013	20"	893023	30"	893068	43"	893046	72"
893012	11"	893075	21"	893016	31"	893036	44"	893047	84"
893005	12"	893015	22"	893025	32"	893037	46"	893048	96"
893006	13"	893083	23"	893058	33"	893038	48"	893057	108"
893007	14"	893017	24"	893027	34"	893039	50"	893054	120"
893085	15"	893074	25"	893018	35"	893061	52"	893132	132"
893009	16"	893019	26"	893029	36"	893040	54"	893087	144"
893014	17"	893084	27"	893031	38"	893079	56"		

## Aluminum Pro-Bar Cross Braces

NUMBER	SIZE	NUMBER	SIZE	NUMBER	SIZE	NUMBER	SIZE
898008	8"	898021	21"	898034	34"	898056	56"
898009	9"	898022	22"	898035	35"	898058	58"
898010	10"	898023	23"	898036	36"	898060	60"
898011	11"	898024	24"	898038	38"	898072	72"
898012	12"	898025	25"	898040	40"	898084	84"
898013	13"	898026	26"	898042	42"	898096	96"
898014	14"	898027	27"	898043	43"	898108	108"
898015	15"	898028	28"	898044	44"	898120	120"
898016	16"	898029	29"	898046	46"	898132	132"
898017	17"	898030	30"	898048	48"	898144	144"
898018	18"	898031	31"	898050	50"		
898019	19"	898032	32"	898052	52"		
898020	20"	898033	33"	898054	54"		

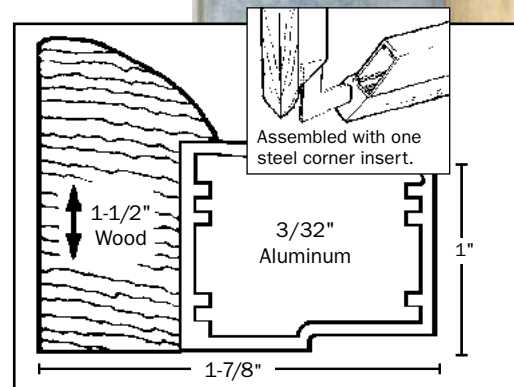

Cross-section of warp-resistant Pro-Bar frame.

**NOTE: ALL SIZES NOT LISTED. LIST AVAILABLE UPON REQUEST. NEED FRACTIONAL SIZES? CALL 1-800-233-2404 FOR INFORMATION.**

## Aluminum Gallery Wrap Stretcher Bars (Box of 6)

Aluminum Gallery Wrap stretcher bars are so beautiful, they don't even need a canvas! The 2.25" profile gives any canvased picture the depth it needs to come alive on a wall.

NUMBER	SIZE	NUMBER	SIZE	NUMBER	SIZE	NUMBER	SIZE
896008	8"	896028	28"	896046	46"	896078	78"
896010	10"	896030	30"	896048	48"	896080	80"
896012	12"	896032	32"	896050	50"	896084	84"
896014	14"	896034	34"	896054	54"	896090	90"
896016	16"	896036	36"	896056	56"	896096	96"
896018	18"	896038	38"	896060	60"	896108	108"
896020	20"	896040	40"	896064	64"	896120	120"
896024	24"	896042	42"	896066	66"		
896025	25"	896044	44"	896072	72"		

## Gallery Wrap Cross Braces

NUMBER	SIZE	NUMBER	SIZE	NUMBER	SIZE
899008	8"	899028	28"	899046	46"
899010	10"	899030	30"	899048	48"
899012	12"	899032	32"	899050	50"
899014	14"	899034	34"	899054	54"
899016	16"	899036	36"	899056	56"
899018	18"	899038	38"	899060	60"
899020	20"	899040	40"	899064	64"
899024	24"	899042	42"	899066	66"
899025	25"	899044	44"	899072	72"

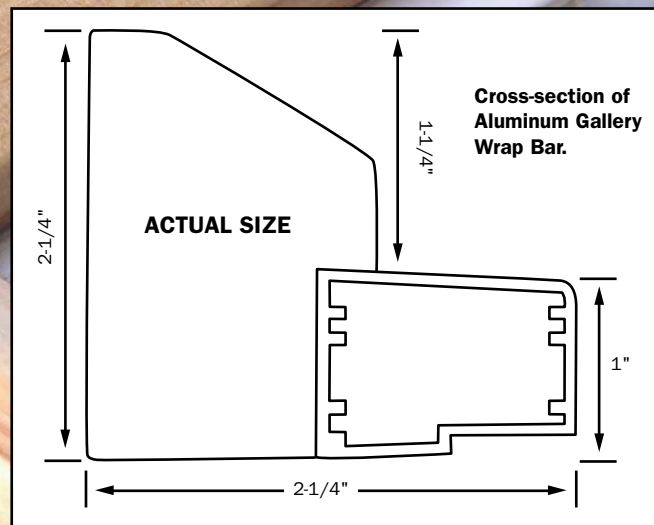

**NOTE: ALL SIZES NOT LISTED. LIST AVAILABLE UPON REQUEST. NEED FRACTIONAL SIZES? CALL 1-800-233-2404 FOR INFORMATION.**

# BEST ALUMINUM HD STRETCHER BARS

The original HD bar with added aluminum for maximum strength

## Aluminum HD Stretcher Bar (Box of 6)

The BEST Aluminum HD Stretcher Bar offers strength, stability, long length capability, and a larger stapling area. It gives you a full 1-3/8" area to staple on the back. We developed the Aluminum HD from combining our ever popular Heavy Duty stretcher bar with the Aluminum Pro. Signature rounded profile allows the canvas to drape over the front eliminating "ghosting."

NUMBER	SIZE	NUMBER	SIZE	NUMBER	SIZE	NUMBER	SIZE
884008	8"	884017	17"	884026	26"	884036	36"
884009	9"	884018	18"	884027	27"	884038	38"
884010	10"	884019	19"	884028	28"	884040	40"
884011	11"	884020	20"	884029	29"	884060	60"
884012	12"	884021	21"	884030	30"	884084	84"
884013	13"	884022	22"	884031	31"	884090	90"
884014	14"	884023	23"	884032	32"	884096	96"
884015	15"	884024	24"	884033	33"		
884016	16"	884025	25"	884034	34"		

TO ORDER ALUMINUM HD CROSS BRACES, ORDER AS: SPECIAL CROSS BRACE FOR ALUM HD STRETCHER BAR AND GIVE US THE SIZE IN INCHES.

NOTE: ALL SIZES NOT LISTED. LIST AVAILABLE UPON REQUEST. NEED FRACTIONAL SIZES? CALL 1-800-233-2404 FOR MORE INFORMATION.

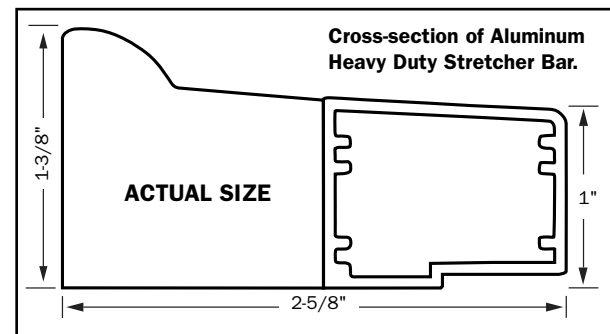

## BEST Cross Brace Bracket

- State-of-the-art design works with all sizes of bars
  - Slotted design allows for finest adjustment of canvas tension
  - Allows bar frame to sit flat against a wall
  - We recommend cross braces for canvas over 36"
  - Contains 2 brackets/screws
  - One unit ships free with each cross brace.
- Additional brackets available for extra cost.

NUMBER 895015

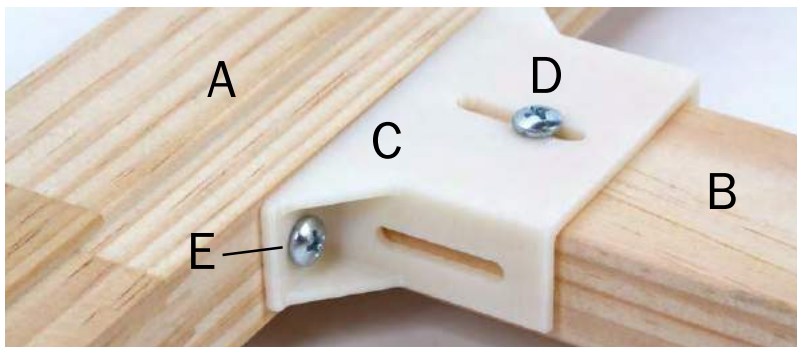

### How to assemble the Cross Brace Bracket

- STEP 1** Assemble your stretcher bars (A).
- STEP 2** Lay your cross braces into position.
- STEP 3** Place your Richeson Cross Brace Bracket (C) #895015 at the end of your Cross Braces (B).
- STEP 4** Attach bracket (C) to brace (B) with 1 to 3 screws (D) as desired. Do not overtighten.
- STEP 5** Attach bracket (C) to pre-assembled frame from step 1 with 2 screws (E).
- STEP 6** After canvas is tightly stretched, apply light pressure to brace and secure screw (D).

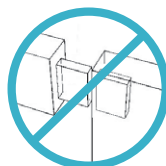

**Eliminates the need for costly tenon joints!**





# LINEAR STOCK

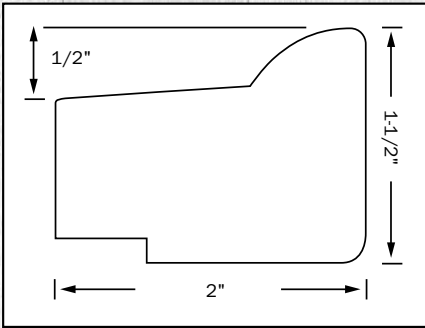

Cross-section of Heavy-duty Stretcher.  
**#899400 HEAVY DUTY Linear Stock**  
 8', 10', 12' Lengths

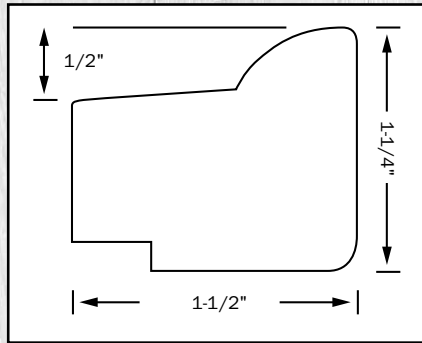

Cross-section of Medium-duty Stretcher.  
**#890700 MEDIUM DUTY Linear Stock**  
 8', 10', 12' Lengths

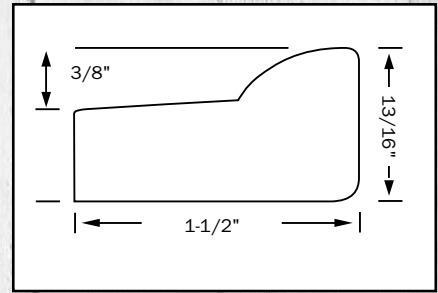

Cross-section of Lightweight Stretcher.  
**#894400 LIGHT DUTY Linear Stock**  
 8', 10', 12' Lengths

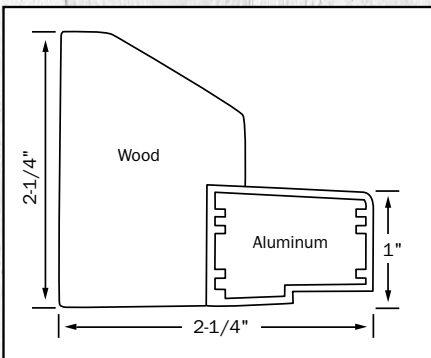

Cross-section of Aluminum Gallery Wrap.  
**#896000 ALUMINUM GALLERY WRAP Linear Stock**  
 8', 10', 12' Lengths

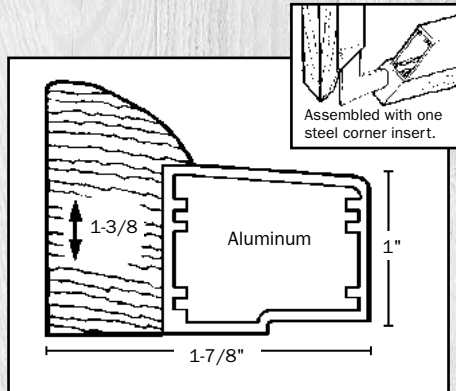

Cross-section of Aluminum Pro.  
**#893500 ALUMINUM PRO Linear Stock**  
 8', 10', 12' Lengths

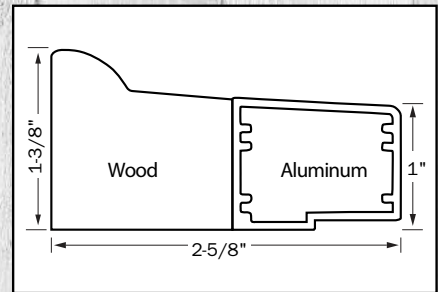

Cross-section of Aluminum HD.  
**#884190 ALUMINUM HD Linear Stock**  
 8', 10', 12' Lengths

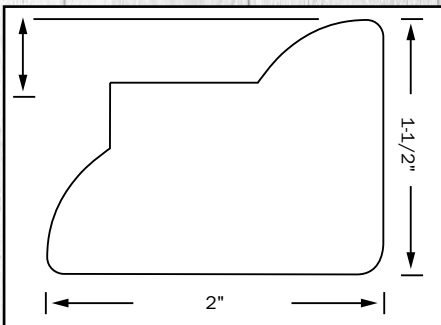

Cross-section of Heavy Duty Double Profile.  
**#899401 HD DOUBLE PROFILE BAR Linear Stock**  
 12' Lengths only. Will cut length to ship.  
 Two bars in one!  
 Same great quality  
 Same high rounded profile

## Splice Kits & Lap Joints

### Splice Kits & Lap Joints

*An oversized frame does not have to mean high shipping costs!*

JRC has developed a Splice Kit (SK) for aluminum bars that will allow you to have extra long lengths but enable you to ship reasonably. Each aluminum bar requires two splice kits for strength and stability. It does not affect the integrity of the bar.

Lap Joints (SKBR) are used for cross braces. Placement is at the manufacturer's discretion. You can request that the holes be predrilled with assembly instructions for a set up charge (SET). Cost is determined by size of the frame.

**Contact your sales representative for more details.**



# STRETCHING ACCESSORIES



## A. Professional Canvas Pliers

Strong! Durable! Lightweight! This professional canvas pliers is large with 4 1/2" wide jaws with rubberized inside grip to hold canvas firmly without marring it.

**NUMBER 400302**

## Canvas Pliers

Great for smaller canvases! These durable imported stretching pliers have serrated jaws for a secure grip to create an even, uniform stretching over stretcher strips or bars.

### NUMBER DESCRIPTION

- B. 400300 Cast Iron Pliers
- C. 400301 Chrome Finish Pliers

## Stretching Stapler

~~This steel, heavy duty stapler has an ergonomic design and lock function. Works well on all the BEST stretcher bars.~~

### NUMBER DESCRIPTION

- D. 895002 BEST stapler
- 895003 BEST staples (5000/box)

## Richeson Aluminum Pro Bar Assembly Kit

Contents:  
8 Aluminum Corners  
8 - (16mm) 5/8" Screws  
4 - BEST Corner Keys

**NUMBER 893998**

*Easy instructions included.*



Corner Keys shown in use

## E. BEST Corner Keys

Each pack contains a set of four keys that can be used on wood stretcher bar frames and Aluminum Pro Bars. Mount keys by using the pre-drilled holes on the Aluminum Pro Bars or by making your own with a 3/32" drill bit. The BEST keys are an essential tool for adjusting the tension of the canvas material just by the turn of a nut!

**NUMBER 890048** \*Required for Aluminum Bars



## F. Hardboard Corners

A simple but worthwhile accessory. These corners are an exact 90° angle to ensure that frame corners will remain square. The pre-drilled holes make mounting easy. Just screw one hardboard panel to each of the four corners of the frame. Sold in packs of 4.  
\*Screws not included.

### NUMBER DESCRIPTION

- 895007-04 8" Corners for small paintings
- 895008-04 12" Corners for large paintings

## Aluminum Corners\*

These steel corner inserts are only to be used with the BEST Aluminum Bars. Use 1 pack (4 corners) for small frames and two packs for heavy pieces or frames over 36" in length. Sold in packs of 4.

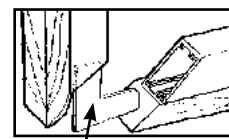

Aluminum Corner

**NUMBER 895020-04** \*Required for Aluminum Bars

# CANVAS STRETCHING 101



## BEST Stretcher Bars by Richeson

### Helpful Tools

Rubber mallet  
Stapler  
Scissors  
Canvas Pliers  
Awl  
Screwdriver

Recommended: Hardboard Corners, BEST Keys (not included)



1. Start by stapling the middle of one side of stretcher bar; repeat on opposite side, pulling taut. Do the same for the other sides, always pulling the canvas taut.



2. Continue stapling working from the center to the corners making sure the staple spacing is even.



3. Please note, do not staple the canvas to the end of corners because you need enough room to manipulate the canvas for tucking the corners. Leave 1"-2".



4. BASIC CUT  
Trim the corners of excess canvas to eliminate bumps when you make a corner. Cut the "dog ear" on an angle.



5. ALT. CUT



6. Begin your corner by folding the canvas straight along the front, fold the side canvas over the top.



7. Bend the first fold over the top of the side fold. Make sure corner lines are neat.

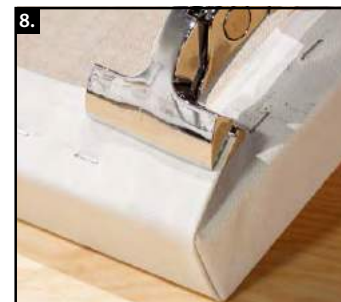

8. Optional: You can use canvas pliers to get the corner tight and flat.



9. Finish stapling.  
*Following steps are optional.*



Wood keys are tapped in the interior corner slots to adjust the tension of the canvas. Place a dab of wood glue on end to hold in place. Take care not to damage canvas.



Some companies staple the corners. If you happen to get a canvas back that is sagging, you can use our BEST Corner Keys to remedy the problem. It's as easy as a turn of a nut! The Best Corner Key can be used on standard stretcher bars and our exclusive Aluminum Bars. If you staple, underpin, or glue your corners, this will break the seal to open the corners up to 1/8". Save time and money by not having to re-stretch the canvas, use BEST Keys!



# STORAGE BOXES

Every artist who wants to work beyond their studio or office will appreciate any number of these storage boxes. Each natural wooden box has its own unique features to help an artist organize supplies for going out on location or traveling to a workshop. Artists may enjoy painting the boxes, and selling them to other artists. Great for stores to use as gift sets.

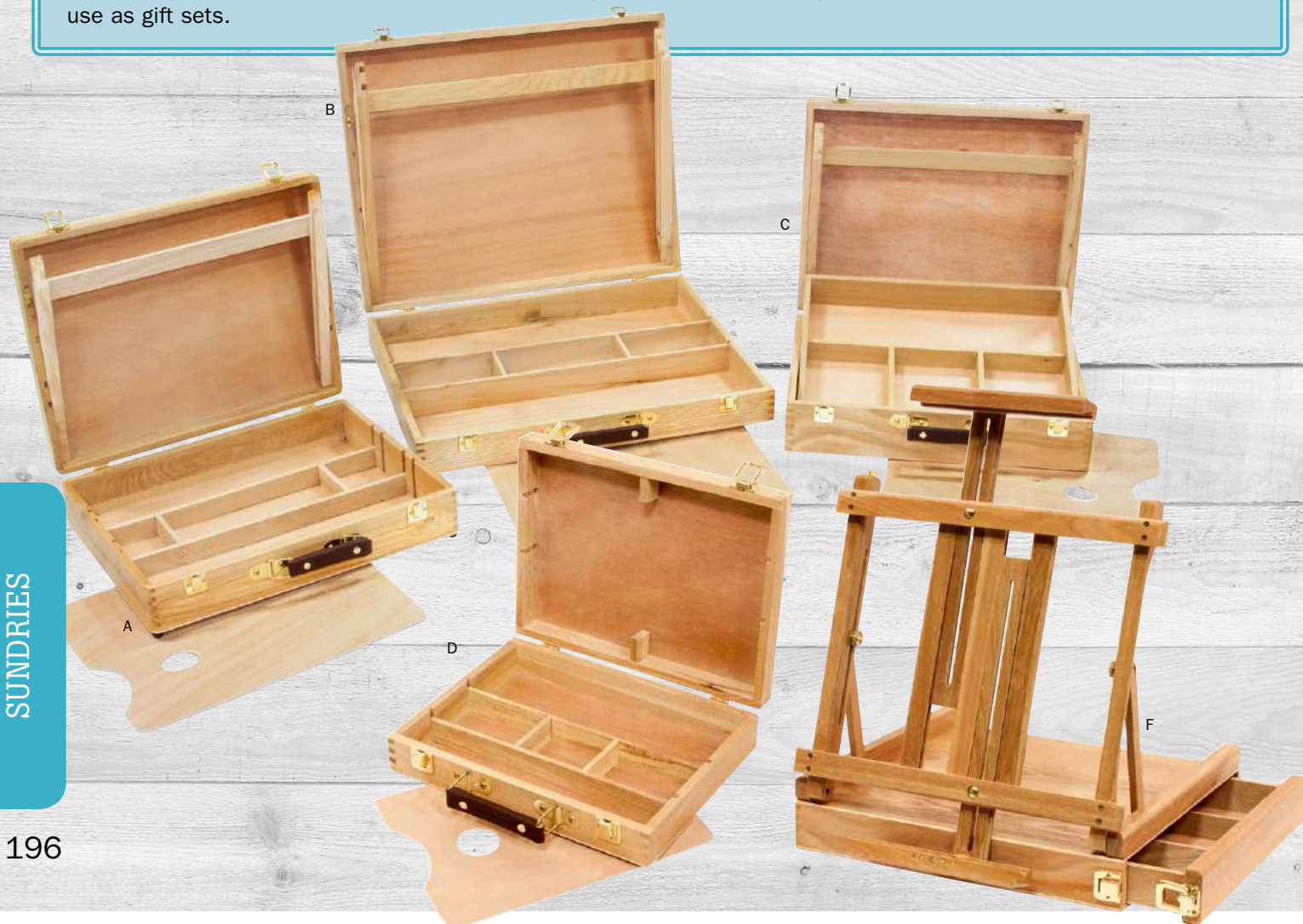

SUNDRIES

196

## Sketch Boxes

These wooden sketch boxes come equipped with a palette that will slide in and out of its own slotted area. Artists are able to store a variety of art supplies!

**NUMBER** **CLOSED DIMENSIONS** (WxLxH)

- A. 696201 16-1/2" x 13" x 4"  
w/2 slots for palettes
- B. ~~696202 20-1/2" x 16-1/2" x 3-3/4"~~  
~~w/2 slots for palettes~~
- C. ~~696207 16-1/2" x 12-7/8" x 4-3/4"~~  
~~w/2 slots for palettes~~  
~~(with removable inner storage tray)~~

## D. ~~Tole Box~~

~~Equipped with a palette and permanent dividers.~~

**NUMBER** **CLOSED DIMENSIONS** (WxLxH)

- 696203 ~~12" x 9" x 2-5/8"~~

## E. ~~The Winner Easel Box~~

~~A super easel box, just like the French Easel but without the legs. Comes with its own palette and will hold a canvas up to 26" high.~~

**NUMBER** **CLOSED DIMENSIONS** (WxLxH)

- 696209 ~~12-1/4" x 16" x 2-1/2"~~

## F. Concord Table Easel Box

Ideal for workshops, dorm rooms, traveling and even studio work. It amazingly holds a canvas panel or pad up to 33" high!

**NUMBER** **CLOSED DIMENSIONS** (WxLxH)

- 848007 15" x 14-7/8" x 4-7/8"



# STORAGE BOXES



**A. Richeson French Mistress** Unlimited uses! Designed to give the artist extra work area and more storage space. Can rest on the drawer of the French easel or any flat surface. Hinged flaps for expanded work space.

- Opened dimensions: 17-3/8" x 41-3/4"
- Closed dimensions: 17-3/8" x 21" x 2-3/8"

**NUMBER 886007**

**B. Richeson French Companion**

The Richeson Covered Palette is included with the French Companion.

- Opened dimensions: 13-1/2" x 33-1/2"
- Closed dimensions: 13-1/2" x 16-3/4" x 2-3/8"

**NUMBER 886006**



## Wood Brush Boxes

A great way to personalize your own brush set. The larger boxes are also great for holding tubes of paint!

- | NUMBER    | DESCRIPTION                                  |
|-----------|--|
| c. 696211 | Small long handle; 15-1/4" x 4" x 1-3/8"     |
| D. 696214 | Large short handle; 7-5/8" x 5-1/4" x 1-5/8" |
| E. 696215 | Large long handle; 13-3/4" x 5" x 1-1/2"     |

## F. Brillion Paintbox #5

The section between the compartments for holding a brush measures 7-7/8" x 1/2" x 1/4". The box has a detachable lid which has bowed metal clips to ensure a tight fit.

- Outside dimensions: 8" x 3-3/8" x 1-1/4"
- Inside compartments: 7-1/4" x 3/4" x 1/2"

**NUMBER 887005**



## Wet Canvas Carrier

Attach the top unit with handle to a wet canvas. Then place another canvas, wet or dry, facing the wet canvas, and the unit keeps the two canvases 1/2" apart. A second unit fastens at the bottom. Fits any size canvas. Empty, the unit will fit in the bottom of a sketch box.

**NUMBER 694010**

# CANVAS PAINTING ACCESSORIES

Constructed of rugged, 100% cotton duck canvas, our canvas accessories are made to last. Whether for use in a studio, classroom or on-location, these quality products will fill a variety of needs.

*100% heavy-duty cotton canvas is made to last!*



A



B



C

D

## A. Full Artist Apron

The apron has large side pockets as well as a large center pocket across the bib. One size fits most in this practical artist accessory.

**NUMBER 945323**

## B. Canvas Brush Roll-up

Protect and secure your brushes in this convenient brush roll-up. Made from 100% cotton canvas, the brush roll-up has nylon trim and ties for durability. Brushes easily slide into the slotted compartments, and the canvas flap folds over to protect brushes. Overall size: 16-3/4" x 21-1/4".

**NUMBER 945327**

## C. French Easel Back Pack

If a French Easel is needed, it can be taken along in this easily shouldered backpack designed specifically for location painters. The 18" x 22" backpack offers room for a French style easel, paper/canvas, and features easily accessible side pockets, convenient handles and comfortably-padded shoulder straps.

**NUMBER 945326**

## D. Artist Tote Bag

Measuring 15" high, 12" wide and 4" deep, this bag comes with carry straps, pockets on each end and a pocket on the front large enough to carry a magazine or notebook. On the back, it has divided brush pockets to carry up to 15 brushes: 10 of the compartments are for short brushes and 5 are for long handles. This tote has many uses but is ideal for students going to and from classes or artists attending workshops.

**NUMBER 945324** (Richeson logo)

**NUMBER 945325** (blank - no logo)



E

*Easy-to-clean apron is perfect for printmakers!*

## E. Grey Matters™ Artist Leatherette Apron

- Easy to clean
- Apron length (top of bib to hem): 33"
- Apron width at widest point: 22"
- Easily adjustable straps at neck and waist make it suitable for artists large and small
- 16 brush pockets for easy access to brushes while working
- Polybagged

**NUMBER 945322**

# PORTFOLIOS

*The must-have item for artists on the go!*



SUNDRIES

199

## Canvas Portfolios

These canvas portfolios, made from heavy-duty nylon, are the perfect solution for transporting artwork. They are designed for easy carrying with adjustable shoulder straps and plastic swivel snap hooks for durability.

### A. Canvas Portfolio with Leather Corners

ITEM	OUTER DIMENSIONS
496304	17" x 22"
496305	20" x 26"
496306	23" x 31"
496308	24" x 36"

### B. Canvas Portfolio (no leather corners)

ITEM	OUTER DIMENSIONS
496206	23" x 31"

## C. Zippered Portfolios

These zippered portfolios feature one compartment with an elastic band for holding paper securely and a plastic handle. Stiff to prevent bending.

NUMBER	INSIDE DIMENSIONS
496003	13-1/4" x 17-3/4"
496004	16-3/4" x 21-3/4"
496005	17-1/4" x 24-1/4"
496006	22-1/2" x 33"

## D. Corrugated Designer Portfolio

A sleek designer portfolio made of 250 lb. cardboard. Overall dimensions are: 28" x 32" with a 3/4" gusset. (Gusset refers to width at base.)

NUMBER 100900 (pack of 12)

# RICHESON PRINTMAKING PRESSES

These presses can be used for a variety of printmaking techniques, including linoleum block printing, collagraph printing, engraving, etching and monoprinting. Richeson Presses are manufactured using quality parts and craftsmanship: heavy castings, steel rollers, and micro pressure gauges. Built rock solid for professionals and priced for artists!

## Presses

NUMBER	DESCRIPTION
695102	11" Baby press
695202	13" Small press
695302	19" Medium press
695402	23" Large press

## Press Stands

NUMBER	DESCRIPTION
695205	13" Small press stand
695305	19" Medium press stand
695405	23" Large press stand

## Complete Press Packages

(includes press, plate, grey cushion)

NUMBER	DESCRIPTION
695100	11" Baby press package
695200	13" Small press package (short bed)
695201	13" Small press package (w/stand/short bed)
695300	19" Medium press package
695301	19" Medium press package (w/stand)
695400	23" Large press package
695401	23" Large press package (w/stand)



Micro pressure gauges for superior control over prints.



Heavy steel rollers for consistent, even pressure.



Individually adjustable feet to ensure premium stability!

## Press Plates

NUMBER	DESCRIPTION
695103	Baby press steel plate 11-11/16" x 19-3/4" x 1/8"
695203	Small press phenolic plate (short) 13-3/4" x 26" x 1/2"
695210	Small press phenolic plate (long) 13-3/4" x 36" x 1/2"
695212	Small press steel plate (long) 13-3/4" x 36" x 1/8"
695303	Medium press phenolic plate 19-5/8" x 36" x 1/2"
695403	Large press phenolic plate 23-5/8" x 36" x 1/2"

## Press Blankets

NUMBER	DESCRIPTION
695104	Baby press cushion (grey) 10-1/2" x 19" x 1/4"
695107	Baby press cushion (white) 10-1/2" x 19" x 1/4"
695108	Baby press pusher (white) 10-1/2" x 19" x 1/8"
695109	Baby press catcher (white) 10-1/2" x 19" x 1/16"
695204	Small press cushion short (grey) 12" x 26" x 1/4"
695213	Small press cushion long (grey) 12" x 36" x 1/4"
695214	Small press cushion short (white) 12" x 26" x 1/4"
695215	Small press cushion long (white) 12" x 36" x 1/4"
695216	Small pusher short (white) 12" x 26" x 1/8"
695217	Small pusher long (white) 12" x 36" x 1/8"
695218	Small catcher short (white) 12" x 26" x 1/16"
695219	Small catcher long (white) 12" x 36" x 1/16"
695304	Medium press cushion (grey) 18" x 36" x 1/4"
695307	Medium press cushion (white) 18" x 36" x 1/4"
695308	Medium press pusher (white) 18" x 36" x 1/8"
695309	Medium press catcher (white) 18" x 36" x 1/16"
695404	Large press cushion (grey) 22-1/2" x 36" x 1/4"
695407	Large press cushion (white) 22-1/2" x 36" x 1/4"
695408	Large press pusher (white) 22-1/2" x 36" x 1/8"
695409	Large press catcher (white) 22-1/2" x 36" x 1/16"

## Press Plate and Blanket Packages (for small press)

NUMBER	DESCRIPTION
695206	Phenolic plate (695203) / cushion (695204)
695207	Phenolic plate (695210) / cushion (695213)
695209	Steel plate (695212) / cushion (695213)



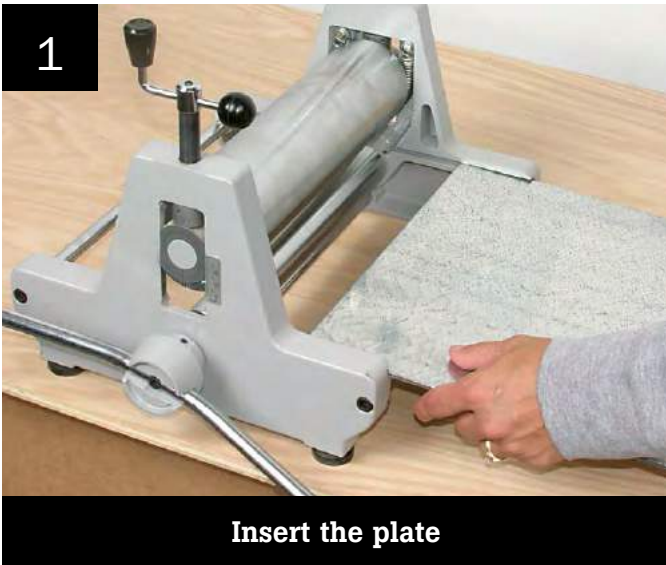

**1**  
Insert the plate



**2**  
Lay down the blankets



**3**  
Adjust the pressure



**4**  
Roll the plate through

Features	Baby Press Package	Small Press Package	Medium Press Package	Large Press Package
Gear ratio	direct drive	2.62:1	2.62:1	3.35:1
Handle	two-point	three-point	three-point	four-point
Plate included	1/8" thick steel	1/2" thick phenolic	1/2" thick phenolic	1/2" thick phenolic
Bed size	11 3/4"(w) x 19 3/4"(l)	13 1/2"(w) x 26"(l)	19 5/8"(w) x 36"(l)	23 5/8"(w) x 36"(l)
Blanket included	1/4" x 10 1/2"(w) x 19"(l)	1/4" x 12"(w) x 26"(l)	1/4" x 18"(w) x 36"(l)	1/4" x 22 1/2"(w) x 36"(l)
Max. print size	9 1/2"(w) x 18"(l)	12"(w) x 25"(l)	17"(w) x 35"(l)	22"(w) x 35"(l)
Upper roll dimensions	3" diam. x 10 3/4"(w)	4 1/2" diam. x 13"(w)	4 1/2" diam. x 19"(w)	4 1/4" diam. x 22 3/4"(w)
Lower roll dimensions	1 1/2" diam. x 10 3/4"(w)	2" diam. x 13"(w)	2" diam. x 19"(w)	3" diam. x 22 3/4"(w)
Clearance (w/o blanket)	15/16"	1 1/4"	1 1/4"	1 5/8"
Base dimensions	13 3/4"(w) x 11 3/4"(l)	16"(w) x 29 1/2"(l)	21 1/2"(w) x 30"(l)	26"(w) x 33"(l)
Shipping weight	69 lbs.	161 lbs.	201 lbs.	318 lbs.
Item number	695100	695200	695300	695400

# RICHESON LINOLEUM

Our linoleum was born out of the need to find a product that would be easy for artists of all ages to carve on. Working with traditional lino tools, it cuts like butter. It leaves beautiful, clean edges and works well on curves and tight corners. It is really an answer for those who have wrestled with tough or hard linoleum in the past. One of its real advantages is its long shelf life — as much as ten times longer than traditional lino — so it stays workable for much longer.

## Easy-To-Cut Lino

- Cuts like butter
- Creates clean edges
- Has a long shelf life
- Unmounted is carvable on both sides!

## Easy-To-Cut Rolls

NUMBER	DESCRIPTION
799070	12" x 50'
799071	12" x 100' (2 rolls – 12" x 50')

## Precut Unmounted

NUMBER	SIZE
799001	3" x 4"
799002	4" x 5"
799003	4" x 6"
799004	5" x 7"
799005	6" x 6"
799006	6" x 8"
799011	6" x 9"
799007	8" x 10"
799008	9" x 12"
799009	12" x 12"
799010	12" x 18"

## Precut Mounted

NUMBER	SIZE
799050	3" x 4"
799051	3" x 5"
799052	4" x 5"
799053	4" x 6"
799054	5" x 7"
799055	5" x 8"
799056	6" x 8"
799057	6" x 9"
799058	8" x 10"
799059	9" x 12"



*The perfect tool for beginning printmakers!*

## Clear Carve Linoleum

- Flexible, durable material
- Easy to carve
- Will not dry out or crack
- Eliminates the need for image transfer
- Speeds up the block printing process
- Ideal for students learning the block printing process
- Any image, photo, or sketch can be used

NUMBER	SIZE
688001	3" x 4"
688003	4" x 6"
688004	5" x 7"
688006	6" x 8"
688007	8" x 10"
688009	12" x 12"
688060	10" x 18"
688061	12" x 24"
688062	18" x 24"
688063	18" x 36"
688064	22" x 30"
688065	22" x 36"



**CLEAR CARVE™**  
BLOCK PRINTING MADE EASY!

# LINOLEUM CUTTING TOOLS



## A. Hard Rubber Brayer

The diameter on each of these brayers measures 1-1/8" and all brayers come with the "back rest" feature for neat resting between inking. Simply turn the handle over on a flat surface when not in use to prevent flattening of the rubber.

NUMBER	DESCRIPTION
699026	2" Wide
699040	2-1/2" Wide
699041	3" Wide
699027	4" Wide
699028	6" Wide
699029	8" Wide

## B. Small Hand Press

All metal construction. Even pressure for excellent reproduction of prints up to 8". At only 6lbs., this little press is perfect for small runs, cards, and school projects!

NUMBER 694097



B

## C. Lino Cutter Set

Six assorted blades and a solid, heavy-duty plastic handle. Packaged to hang. 5-1/8" x 1-5/8" x 1-1/8".

NUMBER 860055

## D. Lino Cutter Handle

Solid heavy-duty plastic handle packaged to hang. Blades sold separately. (See listing at right.)

NUMBER 860062

## E. Heavy-Duty Lino Handle

Storage for blades in the handle! Blades sold separately at right.

NUMBER 860061 (bagged)

## F. Wooden Lino Handle

NUMBER 860064 (bagged)  
 NUMBER 860065 (bagged with 6 blades)  
 NUMBER 860024 (bagged pack of 24)

## Linoleum Cutter Blades

Perfect for use with any of the handles shown at left. Tools can be sharpened on an Arkansas or other fine-grained stone.



## Packs of 6 (LISTED LEFT TO RIGHT)

NUMBER	DESCRIPTION
860071	Deep Gouge
860073	Bowl
860074	Short Gouge
860075	Narrow Gouge
860076	U Shape

## G. Wooden Block Stop

An easy way to make cutting into lino blocks safer. Great for the classroom. 7-1/2" x 10-1/4" work area.

NUMBER 698999

## H. Metal Linoleum Block Stop

Makes cutting into lino blocks safer! Can also be used as an inking surface! 7-1/2" x 10-1/4" work area.

NUMBER 697999

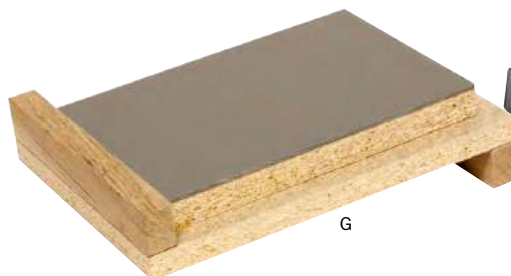

G



H

# MANIKINS

Manikins are excellent reference tools for learning the basics of drawing. The manikins from Jack Richeson are made from smooth hardwood and feature adjustable ball joints. Durable and elegantly finished in a Ph neutral varnish, our manikins are available in a variety of shapes and sizes.

*The perfect tool for classrooms and workshops!*

## Wooden Manikins

These accurately proportioned figures adjust easily to most human positions.

NUMBER	DESCRIPTION
710108	Manikin 4-1/2"
710109	Manikin 6"
710110	Male Manikin 8"
710111	Female Manikin 8"
710112	Male Manikin 12"
710113	Female Manikin 12"
710114	Male Manikin 16"
710115	Female Manikin 16"
710116	Male Manikin 20"
710117	Female Manikin 20"

## Animal Manikins

Make drawing extra fun with life-like manikins from the animal world!

NUMBER	DESCRIPTION
710228	Cat 6"
710230	Horse 22"
<del>710231</del>	<del>Small Horse 12"</del>
710243	Dog 6"
<del>710245</del>	<del>Iguana 8"</del>



## Hand Manikins

Capturing and rendering the gesture and articulation of the human hand is one of the most challenging problems an artist can master. Make it easier with these life-size models.

NUMBER	DESCRIPTION
<del>710219</del>	<del>Child's Left Hand 7"</del>
710220	Male Left Hand 12"
710221	Female Left Hand 10"
710222	Male Right Hand 12"
710223	Female Right Hand 10"



# MODELS & FIGURINES

## Skeleton Models

Ideal for figure drawing, these life-like models have removable arms and legs. Joints are designed to duplicate natural movements. Their mouths open and shut, and one half of the skull comes off. Includes a sturdy stand for display.

NUMBER	DESCRIPTION
710101	Full-size 66"
710102	Medium 33-1/2"
710103	Small 18"

## Life-Size Skull Manikins

Anatomically correct, these are great for teaching, learning, display or hobby. Removable top, and movable lower jaw.

<b>NUMBER 710104</b>	(adult, 19-1/2" circ)
<b>NUMBER 710105</b>	(medium, 10" circ)



*Adult male manikin is almost 6 feet tall!*

Due to the size of the wood pieces, flaws in the wood should be considered normal.

## Life-Size Manikins

NUMBER	DESCRIPTION
710240	Life-Size Male Manikin (70" tall)*
710241	Life-Size Female Manikin (68" tall)*
710242	Life-Size Child Manikin (48" tall)*

\*ships by truck.

## Moving Figurines

These unique templates have riveted joints making them easy to fold up and put in a drawer.

## Large Figurine

13-1/2" High; 12" Arm span.

NUMBER 710227

## Small Figurine

6-3/4" High; 5-3/4" Arm span.

NUMBER 710226

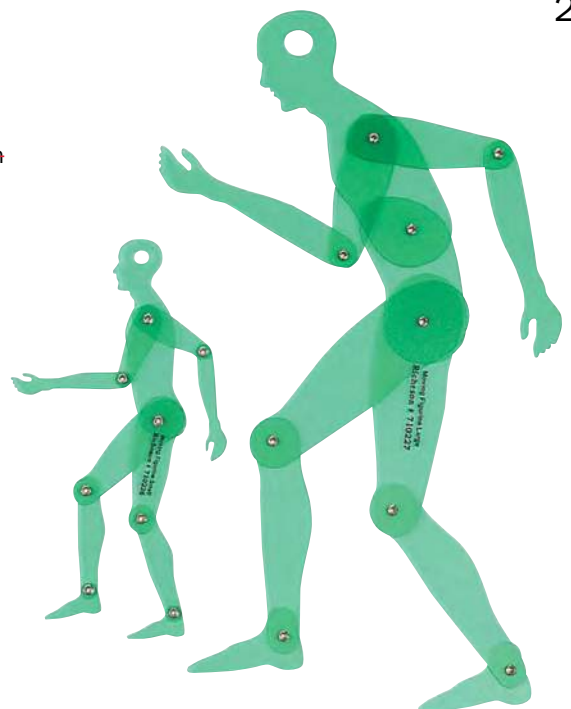

# BRUSH HOLDERS

*Beautiful functionality  
for every artist's needs!*



A



C

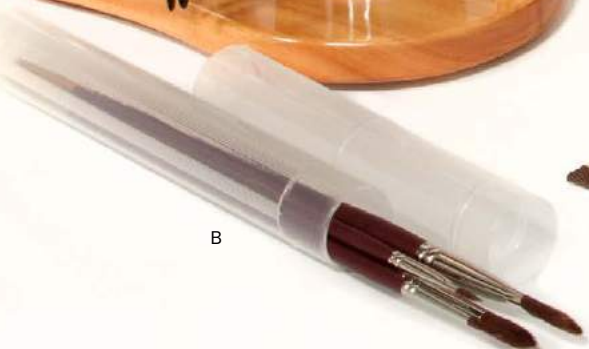

B



D

**A. Lyptus® Wood Brush Holder**

This Lyptus® wood and steel brush holder is elegant, yet functional. (Brushes not included.)

**NUMBER 880050**

**B. Plastic Adjustable Brush Holder**

Great for traveling with brushes! Adjusts up to 12-7/8". (Brushes not included.)

**NUMBER 400218**

**C. Wooden Acrylic Brush Holder**

This wooden brush holder holds an amazing 24 brushes! The top portion is made of clear plexiglass and the bottom has pre-drilled holes so brushes stand upright. Dimensions: 11"(l) x 6"(w) x 5"(h). (Brushes not included.)

**NUMBER 696217** (empty)

**D. Bamboo Mat With Cloth Brush Holder**

Sewn onto the bottom half of this mat is a sectioned brush holder made of 100% cotton cloth. There are 12 slots for brushes ranging from 2" to 5" wide. Just insert each brush handle into the sleeve and roll the mat up. The cloth will help keep brushes from moving and being damaged while transporting from one place to another. Measures 13-3/4" x 14-1/4". (Brushes not included.)

**NUMBER 210531**

# DRAWING BOARDS



## A. Drawing Clip Boards

These heavy-duty drawing boards are just what every student needs. Designed for use in the studio or when painting plein air. They can easily be carried by the convenient cut out handle. Sturdy spring-loaded clips and a heavy-duty rubber band help to keep your artwork secured!

NUMBER	SIZE
400410	11" x 17"
400411	18" x 18"
400413	23" x 26"

## B. Clipboard Rubber Bands

Heavy-duty rubber bands help to keep artwork secured on drawing boards. Extras are always handy!

**NUMBER 400415** (pack of 12)

## C. Lightweight Drawing Boards

These lightweight drawing boards are a firm support for working alone or on an easel. The surface is made of smooth sanded hardwood laminate while the interior is made up of honeycomb matrix – giving you a warp-resistant surface. The metal edge is perfect for working with a T-square!



### Metal Edge

NUMBER	DESCRIPTION
400430-03	<del>16" x 21" (Pk/3)</del>
400431-03	18" x 24" (Pk/3)
400432-03	20" x 26" (Pk/3)

### Wood Edge

NUMBER	DESCRIPTION
400420-03	<del>16" x 21" (Pk/3)</del>
400421-03	<del>18" x 24" (Pk/3)</del>

## D. Cel-Edge T-Squares

Professional T-squares with a clear acrylic edge. Available in the most popular sizes.

NUMBER	DESCRIPTION
400026	18" length
400027	24" length
400028	30" length
400029	36" length
400030	42" length



# PAINING ACCESSORIES



## Paint Pipettes

Paint pipettes are a versatile tool for adding details to your artwork. Use them for marbling, mixing colors, and for applying inks, dyes, and liquid watercolor. Each reusable pipette measures 6-1/4" long.

**NUMBER 101080-25** (Pack of 25)

**NUMBER 101081-50** (Pack of 50)



## Paint Saver Keys

These easy-to-use paint saver keys are a great way to get every bit of paint out of your tubes! Available in small, medium and large sizes.

**NUMBER 400215** (Set of 3 - 1 each size)

**NUMBER 400241-24** (Set of 24 - 8 each size)



## Tube Squeezer

This tool dispenses paint evenly to prevent waste and keeps contents concentrated to maintain softness. It keeps tubes neater and reduces breakage. Use the squeezer on any size tube up to 2-7/8" wide and on any type of tube, including plastic-laminated tubes.

**NUMBER 400304**



## Stackable Drying Rack

Ideal for classroom or studio use where there is never enough counter space to set art projects and prints to dry. Made of raw pine, this rack comes in six 25-1/2" x 17-7/8" pieces. When all six are stacked, the unit is 10-7/8" high. If more drying area is needed, a second rack can be added. Shipping weight: 9 lbs.

**NUMBER 696090**



## Atomizer

The old-fashioned, non-aerosol way to apply fixative. Place the short tube in your mouth and the long tube in your bottle of fixative. Blow gently and evenly, aiming at your drawing. Can also be used to spray watercolors and thinned acrylics for special effects.

**NUMBER 500953**

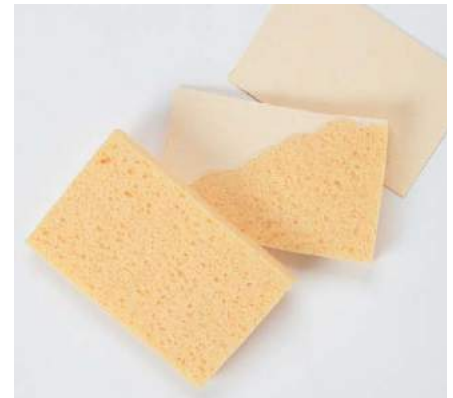

## Compressed Sponges

Miracle Sponges™ are thinly compressed (1/8") cellulose sponges that expand to 5/8" when wet. They can be used in the traditional manner to absorb liquids or clean up messes, but they can also be easily cut or torn into desired shapes for sponge painting or stenciling. These 3" x 4" sponges are reusable and easy to clean.

**NUMBER 710155** (4 per bag)



# HAND CRAFTING TOOLS



## Scratchboard Handles

The cutter tools fit into the end of these scratchboard handles like nibs in a penholder. Artists can use a single handle and exchange blades when needed, or a handle can be purchased for every blade choice. Handles must be ordered in boxes of 12.

**NUMBER 699074**



## Richeson Wood Carving Knife Sets

Quality student-grade wood carving tools. Forged steel gouges mounted on 5" wooden handles.

**NUMBER 400031** (Set of 6)  
**NUMBER 400032** (Set of 12)



## Tjanting Needles

Tjanting needles are used in creating Batik artwork. Traditional Batik is a form of textile art that uses wax as a dye-resist. By pouring hot wax into the needle, this tool allows the artist to draw a pattern directly onto fabric in very fine lines, creating areas on the fabric that will resist dye when applied.

NUMBER	DESCRIPTION
400210	Small
400211	Medium
400212	Large

Handcrafters by Jack Richeson has produced quality looms, school projects and tools for over 25 years. Handcrafter looms and kits have introduced students all across the United States to the wonderful art of weaving.

### A. 5" Modeling Tool

**NUMBER 710569** (pack of 12)

### B. Quilling Tool

For quilling 1/8" paper strips. Measures 6-1/4" in length.

**NUMBER 710573-50** (pack of 50)

### C. Finger Tapestry Loom

This hardwood loom holds up to 38 warp strands and can weave up to 9" wide. Includes a 7" shuttle, a 10-1/2" leah stick and instructions.

**NUMBER 710403**



# BOOKS & VIDEOS

## Books by Jack Richeson

NUMBER	DESCRIPTION
LB0002	Plein Air: New Mexico
LB0004	My Friends: Today's Great Masters
LB0005	Confessions of a Brush Peddler
LB0006	Kate's Legacy

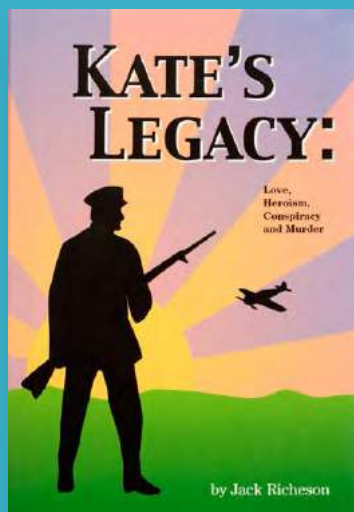
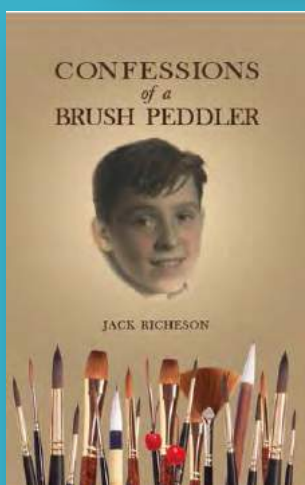
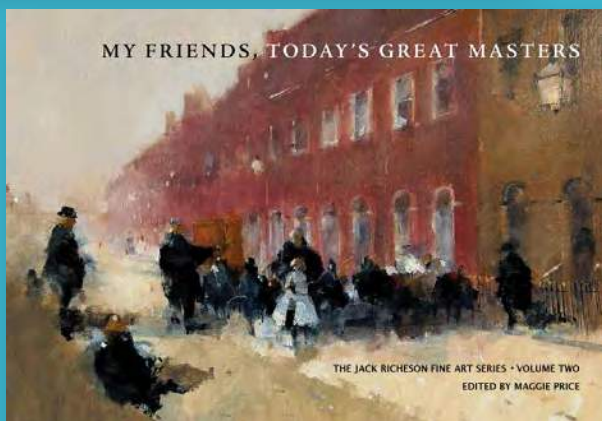
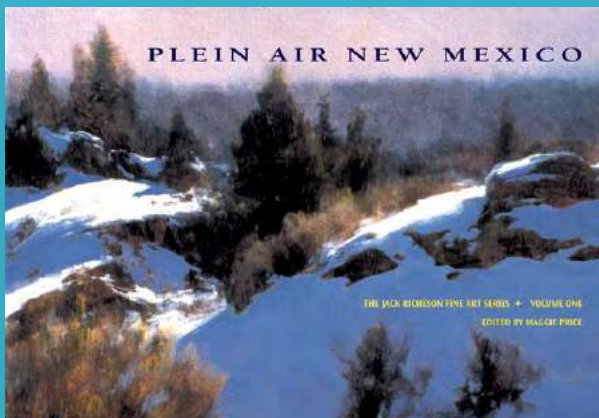

## Stephen Quiller

Award-winning painter, teacher and writer, Quiller is recognized as one of the world's experts in water media. The Complete Water Media Workshop introduces you to watercolor, gouache, casein and acrylic. The video Mastering Color & The Plein Air Experience will show you how to prepare and execute painting in watercolor on-location!

NUMBER	DESCRIPTION
290034	The Complete Water Media Workshop (DVD)
290035	Mastering Color/ Plein Air (DVD)
290036	Color Foundations 2-Disc-Set (DVD)



## E. Artist's ViewCatcher™ View Finder

Use the ViewCatcher™ to create better compositions, make good value judgements, and identify true color. This tool is great for all kinds of artists and students for any style of painting! Measures 3-1/2" x 3-1/2". View finding area: 2" x 2".

NUMBER 499982

# COLOR WHEELS

## A. The Artist's Color Wheel

The "original" standard for every school in the country. The Artist's Color Wheel provides a visual method of demonstrating the relationships of one color to another and the results of color mixing.

**NUMBER 499999** 9-1/4" in diameter

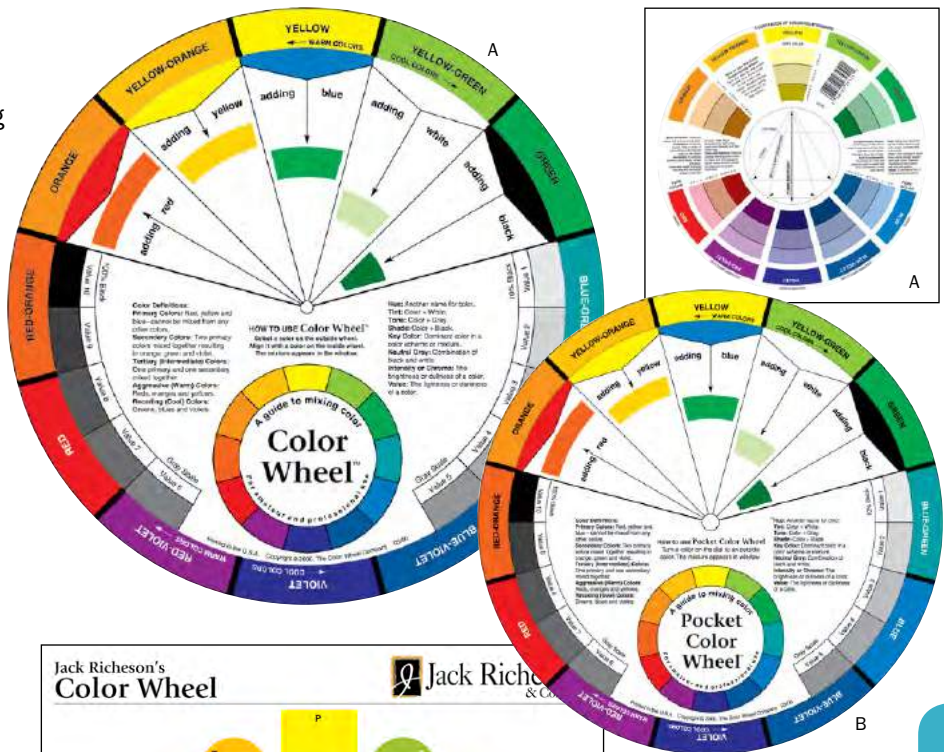

## B. Pocket Color Wheel

A smaller version of the original.

**NUMBER 499986** 5-1/8" in diameter

## C. Richeson Color Wheels

Finally together, a color wheel and gray scale all in one! The extra large is great for classroom use, the smaller one is great for individuals. Both include a gray scale (found on the back of the XL version) and general mixing instructions.

**NUMBER 499970** 19-1/4" x 19-1/4" (XL)

**NUMBER 499975** 7" x 7" - 30 pack (SM)

## D. The Pocket Color Guide

A guide to colors produced by mixing two colors in varying proportions. All colors listed in the guide can be produced by mixing the primary colors: red, yellow, and blue, plus black and white. The 3" x 5" guide unfolds to 30" long. It features a high gloss protective UV coating. Order 24 or more and receive a display box.

**NUMBER 499998**

## E. Gray Scale and Value Finder

A great tool to determine color value in all media. It has a unique cut-out shape which allows easy viewing and accurate readings. It is not just for black and white; it also works great with color.

**NUMBER 499984**

## F. Quiller Color Wheel

Designed by water media master, Stephen Quiller. Since 1988, thousands of painters, crafts people and interior decorators have used this color wheel to help them with color relationships and color mixing. Over 70 highly lightfast artist tube colors are located on the wheel in the order that the painter can have the most accurate analogous, complimentary and triad mixes. Ideal for the professional or student. The wheel is coated with a plastic laminate and includes instructions.

**NUMBER 499987** 8-1/2" x 8-1/2"

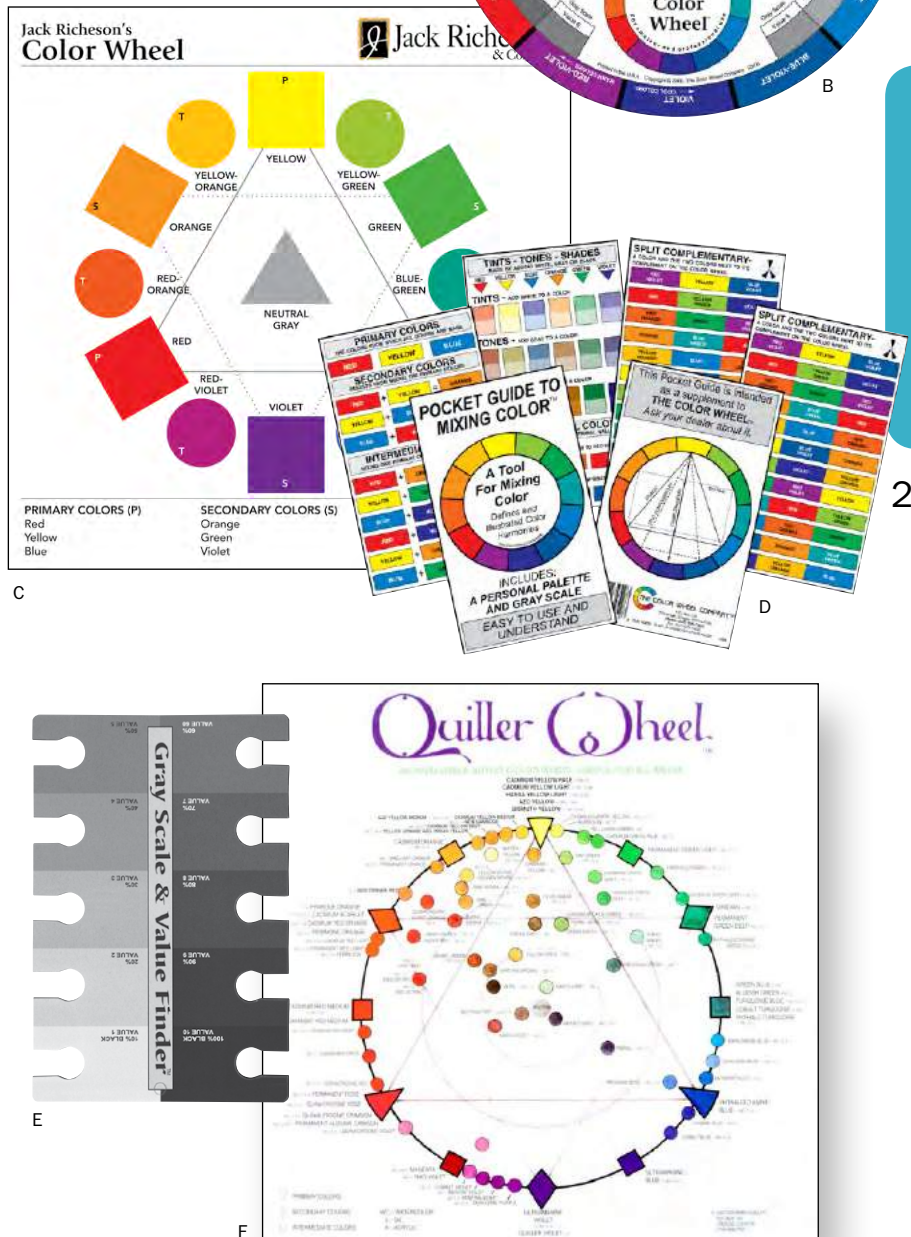

SUNDRIES

211

www.richesonart.com  
1.800.233.2404

# NUMERICAL BRUSH INDEX

Series	Description	Page	Series	Description	Page	Series	Description	Page
410	Shiva Economy Stencil Brushes	44	7550	Synthetic Oil/Acrylic Filberts	41	9240	Chelveston Bristle Fans	31
1220	Richeson Bristle Stencil Brushes	44	7610	Dagger Stripper	43	9420	English Spalters	33
2040	Squirrel Watercolor Rounds	19	7777	Extreme Kolinsky Watercolor Rounds	15	9537	Bristle Flat Fresco	34
2046	Sable Watercolor Liners	17	7778	Extreme Kolinsky Watercolor Flats	15	9538	Blue Synthetic Flats	42
2047	Pure Sable Fan Brushes	39	8000	White Synthetic Watercolor Rounds	23	9579	Student Bristle Flats	32
2051	Kazan Squirrel Flat Brushes	18	8010	White Synthetic Watercolor Flats	23	9582	Student Bristle Rounds	32
2060	Squirrel Sky Wash Brushes	19	9000	Synthetic Watercolor Rounds	22	9617	Signature Bristle Rounds	28
2061	Squirrel Watercolor Mop Brushes	19	9010	Synthetic Watercolor Flats	22	9626	Signature Bristle Filberts	29
4020	Wooden Handle Stubby Brushes	48	9017	Chelveston Bristle Rounds	30	9627	Signature Bristle Brights	28
5101	White Horse Bamboo Brushes	26	9020	Synthetic Watercolor Liners	22	9628	Signature Bristle Flats	28
5103	Wool Hake Brushes	25	9026	Chelveston Bristle Filberts	31	9629	Signature Bristle Egberts	29
5113	Goat Hair Watercolor Brushes	25	9027	Chelveston Bristle Brights	30	9640	Signature Bristle Fans	29
5130	Soft Bristle Flats	25	9028	Chelveston Bristle Flats	30	9701	White Bristle Stencil	43
5150	Bristle Chip Brushes	33	9029	Chelveston Bristle Egberts	31	9704	White Synthetic Liners	23
5210	Rabbit Hair Watercolor Brushes	25	9049	Domed Sash Brushes	35	9811	Grey Matters Synthetic Oil Rounds	10
5214	Rabbit Hair Watercolor Brushes	25	9100	Aquarelle Watercolor Flats	21	9812	Grey Matters Synthetic Oil Flats	10
5242	Multi-Head Bamboo Brushes	26	9117	Sable Oil Rounds	38	9813	Grey Matters Synthetic Oil Filberts	10
5706	White Horse Bamboo Brushes	26	9118	Orange Synthetic Rounds	40	9814	Grey Matters Synthetic Oil Brights	10
5820	Bristle Stencil Brushes	44	9129	Bristle Oval Fresco	34	9815	Grey Matters Signing Brushes	11
5829	Glue Brushes	43	9129	Waxing Brushes	43	9821	Grey Matters Acrylic Rounds	11
6228	Sable Watercolor Rounds	16	9149	Pointed Sash Brushes	35	9822	Grey Matters Acrylic Flats	11
6229	Sable Watercolor Flats	16	9151	Black Bristle Easel Flats	32	9823	Grey Matters Acrylic Filberts	11
7000	Quiller Watercolor Rounds	21	9152	Szabo Bristle Slants	24	9824	Grey Matters Acrylic Brights	11
7010	Quiller Watercolor Flats	21	9155	Soft Bristle Spalters	33	9831	Grey Matters Watercolor Rounds	12
7152	SH Domed Sash Brushes	35	9158	Synthetic Flat Gesso	34	9832	Grey Matters Watercolor Flats	12
7154	SH Pointed Sash Brushes	35	9160	Sable Oil Brights	38	9833	Grey Matters Watercolor Liners	12
7160	Kolinsky Sable Oil Filberts	37	9161	Sable Oil Filberts	38	9841	Grey Matters Bristle Oil Rounds	9
7161	Kolinsky Sable Oil Brights	37	9164	Orange Synthetic Brights	40	9842	Grey Matters Bristle Oil Flats	9
7162	Kolinsky Sable Oil Rounds	37	9165	Orange Synthetic Filberts	40	9843	Grey Matters Bristle Oil Brights	9
7163	Kolinsky Sable Oil Flats	37	9166	White Synthetic Oil/Acrylic Brights	42	9844	Grey Matters Bristle Oil Filberts	9
7223	Sable Watercolor Rounds	16	9167	White Synthetic Oil/Acrylic Rounds	42	9845	Grey Matters Bristle Oil Egberts	9
7500	Synthetic Oil/Acrylic Rounds	41	9168	White Synthetic Oil/Acrylic Filberts	42	9846	Grey Matters Bristle Oil Fans	9
7530	Synthetic Oil/Acrylic Flats	41	9211	Economy Flat Gesso	34			



# ALPHABETICAL CATALOG INDEX

Description	Page	Description	Page	Description	Page
A A-Best Easel, BEST	119	Clay Cutters	172	K Kate Palmer Taboret, BEST	130
Abiquiu Easels, BEST	112-113	Clean-up Tools	169	Kelley Crank Easel, BEST	116
Adjustable Brush Holder	206	Clipboards	207	Knife Assortments	57
Aluminum Calipers	172	Color Wheels	211	Knives	53-57
Aluminum Stretcher Bars	191	Compressed Sponges	208	Kolinsky Sable Oil Brushes	37
Aluminum Trays	162	Corner Keys, BEST	194	Kolinsky Sable Watercolor Brushes	15-16
Ambrosia Print Rack	152	Corrugated Portfolios	199		
Aprons	198	Cradled Hardboard	182	L La Vara Table Easel	144
Armatures & Armature Wire	168	Crank Easel, BEST	116	Lace Tools	171
Armed Palettes	154	Creative Mark Palette	159	Lancaster Easel, Lyptus	143
Art Cart, BEST	136	Cross Braces	189-191	Leatherette Apron	198
Artist Organizer	127	Cross Brace Bracket	192	Lightweight Drawing Boards	207
Artist Tote Bags	198	Cutting Tools, Pottery	170	Lightweight Stretcher Bars, BEST	190
Artist Viewfinder	210			Liners	12, 17, 22
Aquarelle Brushes	21	D Dagger Striper	43	Linoleum	202
Atomizer	208	Deluxe Lobo Easel, BEST	121	Linoleum Block Stops	203
Aztec Easel, Lyptus	142	Deluxe Table Top Easel, Lyptus	144	Linoleum Tools	203
		Deluxe Table Top Easel, BEST	132	Lite A-Best Easel, BEST	119
B B.F.E. Easy, BEST	128-129	De Pere Field Easel	149	Lite B-Best Easel, BEST	119
B-Best Adjustable Easel, BEST	119	Display Easel, Chrome	151	Little Palette Tray	159
B-Best Easel, BEST	119	Disposable Palette Pads	178	Lobo Easel, Lyptus	142
Backpack	198	Donkey Benches	139	Lobo Easel, BEST	121
Bamboo Brush Mats	206	Double-Sided Easel, Lyptus	146	Lock Box Palette	163
Bamboo Reed Pens	26	Double Ball Stylus Tools	171	Loom	209
Bassett Easel, Lyptus	141	Drawing Boards	207	Lynch Porcelain Palette	156
Becky Taboret, BEST	134	Drawing Pads	176	Lyptus® Wood Easels	140-143
BEST Easels	110-139	Drawing Sticks	108		
BEST Corner Keys	194	Drying Rack	208	M Maestro Easel	151
Belmont Easel, Lyptus	142	Dulce Easel, Lyptus	141	Maestro Jr. Easel	151
Bennett Table Top	144	Dulce Easels, BEST	118	Mahl Sticks	133
Book Making Class Packs	180	DVDs	210	Manhattan Easel, BEST	117
Boxwood Modeling Tools	173			Manikins	204-205
Brayers	47, 203	E Easel Brushes	32	Mantoya Easel, Lyptus	143
Brillion Paintboxes	197	Easels	110-151	Manzano Easel, BEST	122
Bristle Brushes	24-35	Eco Sketch Journals	176	Medium-duty Stretcher Bars	190
Brush Assortments	50-52	Elegant H-Frame Easel, BEST	117	Mediums, Richeson	80-81
Brush Bags	52	European Easel, BEST	123	Melamine Palettes	154
Brush Basins	166	Extreme Kolinsky Brushes	15	Melamine Tab Trays	113
Brush Boxes	197			Miniature Porcelain Trays	157
Brush Cylinders	49	F Faux Finishing Brushes	43	Modeling Tools	168-174
Brush Holders	206	Fettling Knife	170	Modular Work Station	137
Brush Mats	206	Figurines	205	Muffin Trays	161
Brush Roll-up	206	Finger Tapestry Loom	209		
Brush Sets	45-49	Flat Files	136	N Navajo Easel, Lyptus	143
Brush Washers	166	Flower Dishes	161	Navajo Easel, BEST	124
Brushes	8-52	Foam Brushes	47	Neatness Jars	165
Bulk Paper	179	Foam Inserts for Pastel Boxes	98	Newsprint Pads	177
Butcher Trays	162	Folding Watercolor Palettes	160	Nylon Clay Cutter	170
		French Companion	197		
C Caballitto Donkey Bench	139	French Easel Backpack	198	O Oak Flat File	136
Caballo Donkey Bench, BEST	139	French Easels	149	Oil/Acrylic Brushes	27-42
Caitlin Taboret, BEST	134	French Mistress	197	Oil Paints	58-63
Calipers	172	Fresco Brushes	34	Oil Pastels	86
Calligraphy Brushes	25				
Canisters	133	G Galestio Print Racks	152	P Paint & Color	58-108
Canvas, Caravaggio	186-187	Gallery Wrap Stretcher Bars, BEST	191	Paint Dispenser	162
Canvas Carriers	197	Gesso	81	Paint Saver Keys	208
Canvas Pliers	194	Gessoed Hardboard Panels, Richeson	182	Paint Tube Squeezer	208
Canvas Portfolios	199	Giant Dulce Easel, BEST	118	Painting Knives	53-57
Canvas Print Racks	153	Giant Dulce Easel, Lyptus	141	Painting Mediums	80-81
Canvas Scraping Knives	56	Gouache	86	Paintstiks	64-69
Caravaggio Canvas	186-187	Grayscale & Value Finder	211	Palette Cups	155
Carving Tools	209	Grey Matters Paper Palette Pad	178	Palette Knives	53-57
Cascade Easel, Lyptus	143			Palettes	154-163
Casein Paints	70-75	H Hand Press	203	Paper	175-180
Casters	117	Handcrafters Loom	209	Paper Palette Pads	178
Cel-edge T-Squares	207	Heavy-duty Stretcher Bars, BEST	189	Paper Soaking Trays	162
Ceramic Tool Set	169	Hake Brushes	25	Pastel Assortments	98, 100, 104
Chamois	109	Halley Easel, BEST	122	Pastel Cases	107
Charcoal	109	Hardboard Corners	194	Pastel Paper/Surfaces	184-185
Charcoal Holder	109	Hardboard Panels	181-183	Pastel Trays	107
Chelveston Bristle Brushes	30-31	Hole Cutters	170	Pastels	93-108
Children's Paint Sets	88-92			Plaster Tools	170
Chimayo Easels, BEST	125	I Interior Design Color Wheel	211	Plastic Painting Knives	57
Chinese Bamboo Brushes	26			Plastic Palettes	158-161
Chinese Watercolor Brushes	25-26	J Jackson Pastels	106	Playcolor	84-85
Chipboard, All Purpose	179	"JJ" Easel	146	Plein Air Equipment	148-149
Clamp-on Steel Table Easel	150	"JJ" Table Top Easel	146	Porcelain Palettes	156-157
Classic Dulce Easel, BEST	118	Jack's Linseed Studio Soap	81	Portable Collapsible Easel, BEST	123
Classic Santa Fe Easels, BEST	115			Portfolios	199

Description	Page	Description	Page	Description	Page
Potter's Ribs .....	173	Stomps .....	108	Disclaimer: Every effort has been made to assure the accuracy of this catalog. However, please note that vendor packaging changes may occur and items may be added, changed, or discontinued after going to print. Please inquire if you have a question or concern.	
Pottery Loops .....	174	Stools .....	147		
Pottery Tools .....	169-174	Stretcher Bars, BEST .....	188-193		
Pottery Wheels .....	167	Stretcher Bar Display Racks .....	188		
Print Making Presses .....	200-201	Stretching Accessories .....	194		
Print Racks .....	152-153	Stubby Brushes .....	48		
<b>Q</b> Quiller Color Wheel .....	211	Student Brushes .....	47-49		
Quiller Covered Palettes .....	158	Student Paint Sets .....	88-92		
Quiller Porcelain Palette .....	156	Student Watercolor Pads .....	175		
Quiller Videos .....	210	Studio Taboret, BEST .....	135		
Quiller Water Media Brushes .....	20-21	Stylus Tools .....	171		
Quiller Watercolor Blocks .....	175	Szabo Watercolor Brushes .....	24		
Quiller Watercolor Paints .....	76-77	<b>T</b> T-Squares .....	207		
Quilling Tool .....	209	Tab Trays .....	113		
<b>R</b> Racine Table Top Easel, Lyptus .....	144	Table Easels .....	144		
Rasps .....	170	Table Easel Box .....	196		
Red Sable Oil Brushes .....	37	Taborets .....	130-138		
Reed Pens .....	26	Taos Watercolor Taboret .....	138		
Ribbon Wire Tools .....	174	Tempera Blocks .....	91-92		
Rice Paper .....	180	Tempera Cake Trays .....	161		
Richeson Covered Palette .....	158	Tempered Hardboard Panels .....	183		
Richeson Charcoal .....	109	Terrero Taboret, BEST .....	132		
Richeson Easels .....	145	Texture Tool Set .....	170		
Richeson Pastels .....	99-103	Tjanting Needles .....	209		
Richeson Paint Sets .....	88	Tole Box .....	196		
Richeson Watercolor Pads & Blocks .....	175	Tortillions .....	108		
Riffler Set .....	171	Tote Bags .....	198		
Rio Grande Easel, BEST .....	124	Tracing Pads .....	177		
Roz Bags/Boxes .....	107	Transfer Paper .....	180		
Rubber Brayers .....	203	Tri Art Acrylics and Mediums .....	82-83		
<b>S</b> Sandpaper Pads .....	109	Tri Art Palette .....	155		
Saber Saw Tool .....	170	Tube Squeezer .....	208		
Sable Oil Brushes .....	37	<b>U</b> Ultimate Brush Washer .....	166		
Sable Watercolor Brushes .....	16	Unison Soft Pastels .....	93-98		
Sanguine & Sepia Drawing Sticks .....	108	Unison Pastel Assortments .....	98		
San Pedro Easel, BEST .....	118	University Easel, BEST .....	120		
Santa Fe Easels, BEST .....	115	Untempered Hardboard Panels .....	183		
Santa Fe II, Lyptus .....	140	Urania's Desk, BEST .....	131		
Sash Brushes .....	35	<b>V</b> Videos, DVDs .....	210		
Sauce Drawing Sticks .....	108	Viewfinder .....	210		
Scratchboard Tools .....	209	<b>W</b> Wallmount Easel, BEST .....	120		
Sculpture & Pottery Tools .....	169-174	Water Cups .....	164		
Sculpture Thumb .....	172	Watercolor Brushes .....	12-26		
Seneca Table Easel .....	144	Watercolor Lobo Easel, BEST .....	121		
Sgraffito Tool .....	171	Watercolor Paper .....	175		
Shawn's Watercolor Station, BEST .....	131	Watercolor Sets .....	86-90		
Shelf Help .....	147	Watercolor Taboret, BEST .....	131		
Shiva Paintstiks .....	64-69	Watercolors .....	76-79		
Shuttle for Loom .....	209	Weston French Easels .....	149		
Signature Bristle Brushes .....	28-29	Wet Canvas Carrier .....	195		
Sitha Taboret, BEST .....	133	Winner Easel Box .....	196		
Skeleton Models .....	205	Wipe Out Tool .....	172		
Sketch Boxes .....	196	Wire End Tools .....	174		
Sketch Pads .....	176	Wire Clay Cutter .....	170		
Sketch Sticks .....	106	Wood Carving Tools .....	209		
Skull Manikins .....	205	Wood Print Racks .....	152		
Slant Brushes .....	24	Wooden Brush Holders .....	206		
Spalter Brushes .....	33	Wooden Manikins .....	204-205		
Spatter Seize .....	172	Wooden Palettes .....	154		
Speckling Brush .....	172	Wooden Boxes, Empty .....	196-197		
Sponges .....	208	<b>Y</b> Yarka Paint Sets .....	87		
Squirrel Watercolor Brushes .....	18-19	Yarka Pastels .....	108		
St. Petersburg Watercolors .....	78-79	Yarka Sanguine & Sepia .....	108		
Stainless Steel Brush Holders .....	206	<b>Z</b> Zoltan Szabo Covered Palette .....	158		
Stainless Steel Canisters .....	133	Zoltan Szabo Watercolor Brushes .....	24		
Stainless Steel Knives .....	53, 56				
Stapler .....	194				
Steel Easels .....	150-151				
Steel Lyre Easel .....	151				
Steel Rasps .....	170				
Steel Plaster Tools .....	171				
Steel Print Rack .....	153				
Steel Scrapers .....	172				
Steel Table Easel .....	150				
Steel Tripod Easels .....	150				
Stencil Brushes .....	44				

**Jack Richeson & Co., Inc.**  
**MASTERS OF FINE ART MATERIALS**

**Jack Richeson** – CEO  
**Darren Richeson** – President  
**Shawn Richeson** – Executive VP Manufacturing  
**Kelly Richeson Fink** – VP Finance  
**Colleen Richeson Maxey** – VP Sales & Marketing  
**Michael Richeson** – VP Key Accounts

Copyright ©2016 by Jack Richeson & Co., Inc.

All rights reserved. No part of this catalog may be reproduced in any form without written permission of the copyright owners. All images in this catalog have been reproduced with the knowledge and prior consent of the artists concerned.

Art Director: Maria Kamin  
 Photography: Kimberly Kamin  
 Catalog Director: Rachelle Hansen  
 PRINTED IN CHINA  
 Regent Publishing Services Limited